

# SECTION **TM**

## TRANSAXLE & TRANSMISSION

A  
B  
C  
**TM**

### CONTENTS

<b>CVT: RE0F10A</b>			
<b>BASIC INSPECTION</b> .....	4	System Description .....	29
<b>DIAGNOSIS AND REPAIR WORK FLOW</b> .....	4	Component Parts Location .....	30
Work Flow .....	4	Component Description .....	31
Diagnostic Work Sheet .....	4	<b>SHIFT LOCK SYSTEM</b> .....	33
<b>FUNCTION DIAGNOSIS</b> .....	6	System Description .....	33
<b>CVT SYSTEM</b> .....	6	Component Parts Location .....	35
System Diagram .....	6	Component Description .....	35
Component Parts Location .....	7	<b>ON BOARD DIAGNOSTIC (OBD) SYSTEM</b> ....	36
<b>MECHANICAL SYSTEM</b> .....	9	Diagnosis Description .....	36
Cross-Sectional View .....	9	<b>COMPONENT DIAGNOSIS</b> .....	37
System Diagram .....	10	<b>SHIFT POSITION INDICATOR CIRCUIT</b> .....	37
System Description .....	10	Description .....	37
Component Parts Location .....	11	<b>SHIFT LOCK SYSTEM</b> .....	38
Component Description .....	12	Description .....	38
<b>HYDRAULIC CONTROL SYSTEM</b> .....	14	Wiring Diagram - CVT SHIFT LOCK SYSTEM - ....	38
System Diagram .....	14	Component Function Check .....	39
System Description .....	15	Diagnosis Procedure .....	40
Component Parts Location .....	16	Component Inspection (Stop Lamp Switch) .....	41
Component Description .....	18	Component Inspection (Shift Lock Solenoid) .....	41
<b>CONTROL SYSTEM</b> .....	20	<b>ECU DIAGNOSIS</b> .....	42
System Diagram .....	20	<b>TCM</b> .....	42
System Description .....	21	Reference Value .....	42
Component Parts Location .....	21	Wiring Diagram - CVT CONTROL SYSTEM - ....	45
Component Description .....	23	Fail-safe .....	46
<b>LOCK-UP AND SELECT CONTROL SYSTEM</b> .....	25	<b>SYMPTOM DIAGNOSIS</b> .....	48
System Diagram .....	25	<b>SYSTEM SYMPTOM</b> .....	48
System Description .....	25	Symptom Table .....	48
Component Parts Location .....	25	<b>PRECAUTION</b> .....	59
Component Description .....	27	<b>PRECAUTIONS</b> .....	59
<b>SHIFT CONTROL SYSTEM</b> .....	29	Precaution for Supplemental Restraint System (SRS) "AIR BAG" and "SEAT BELT PRE-TEN- SIONER" .....	59
System Diagram .....	29		

Precaution Necessary for Steering Wheel Rotation After Battery Disconnect .....	59	<b>PARK/NEUTRAL POSITION (PNP) SWITCH...</b>	87
Precaution for Procedure without Cowl Top Cover..	60	Exploded View .....	87
Precaution for On Board Diagnosis (OBD) System of CVT and Engine .....	60	Removal and Installation .....	87
Removal and Installation Procedure for CVT Unit Connector .....	60	Inspection and Adjustment .....	87
Precaution .....	61	<b>PRIMARY SPEED SENSOR .....</b>	89
Service Notice or Precaution .....	62	Exploded View .....	89
<b>PREPARATION .....</b>	63	Removal and Installation .....	89
<b>PREPARATION .....</b>	63	Inspection .....	89
Special Service Tools .....	63	<b>SECONDARY SPEED SENSOR .....</b>	90
Commercial Service Tools .....	63	Exploded View .....	90
<b>ON-VEHICLE MAINTENANCE .....</b>	65	Removal and Installation .....	90
<b>CVT FLUID .....</b>	65	Inspection .....	90
Inspection .....	65	<b>DIFFERENTIAL SIDE OIL SEAL .....</b>	91
Changing .....	66	<b>2WD .....</b>	91
<b>STALL TEST .....</b>	67	2WD : Exploded View .....	91
Inspection and Judgment .....	67	2WD : Removal and Installation .....	91
<b>LINE PRESSURE TEST .....</b>	69	2WD : Inspection .....	92
Inspection and Judgment .....	69	<b>4WD .....</b>	92
<b>ROAD TEST .....</b>	71	4WD : Exploded View .....	92
Description .....	71	4WD : Removal and Installation .....	92
Check before Engine Is Started .....	71	4WD : Inspection .....	93
Check at Idle .....	71	<b>OIL PUMP FITTING BOLT .....</b>	94
Cruise Test .....	72	Description .....	94
<b>CVT POSITION .....</b>	74	Exploded View .....	94
Inspection and Adjustment .....	74	Removal and Installation .....	94
<b>ON-VEHICLE REPAIR .....</b>	75	Inspection .....	94
<b>TRANSMISSION CONTROL MODULE .....</b>	75	<b>AIR BREATHER HOSE .....</b>	95
Exploded View .....	75	Exploded View .....	95
Removal and Installation .....	75	Removal and Installation .....	95
<b>CONTROL DEVICE .....</b>	76	<b>FLUID COOLER SYSTEM .....</b>	96
Exploded View .....	76	<b>WATER HOSE .....</b>	96
Removal and Installation .....	76	WATER HOSE : Exploded View .....	96
Inspection and Adjustment .....	79	WATER HOSE : Removal and Installation .....	96
<b>CONTROL CABLE .....</b>	80	WATER HOSE : Inspection .....	98
Exploded View .....	80	<b>FLUID COOLER (FOR AUSTRALIA AND MIDDLE EAST) .....</b>	98
Removal and Installation .....	80	FLUID COOLER (FOR AUSTRALIA AND MIDDLE EAST) : Exploded view .....	99
Inspection and Adjustment .....	81	FLUID COOLER (FOR AUSTRALIA AND MIDDLE EAST) : Removal and Installation .....	99
<b>KEY INTERLOCK CABLE .....</b>	82	FLUID COOLER (FOR AUSTRALIA AND MIDDLE EAST) : Inspection .....	101
Exploded View .....	82	<b>FLUID COOLER (EXCEPT FOR AUSTRALIA AND MIDDLE EAST) .....</b>	101
Removal and Installation .....	82	FLUID COOLER (EXCEPT FOR AUSTRALIA AND MIDDLE EAST) : Exploded view .....	102
Inspection .....	84	FLUID COOLER (EXCEPT FOR AUSTRALIA AND MIDDLE EAST) : Removal and Installation .....	102
<b>OIL PAN .....</b>	85	FLUID COOLER (EXCEPT FOR AUSTRALIA AND MIDDLE EAST) : Inspection .....	104
Exploded View .....	85		
Removal and Installation .....	85		
Inspection .....	86		

<b>REMOVAL AND INSTALLATION</b> .....	105	Disassembly .....	113	A
<b>TRANSAXLE ASSEMBLY</b> .....	105	Assembly .....	113	
<b>2WD</b> .....	105	Inspection .....	114	
2WD : Exploded View .....	105	<b>SERVICE DATA AND SPECIFICATIONS</b>		B
2WD : Removal and Installation .....	105	<b>(SDS)</b> .....	115	
2WD : Inspection .....	108	<b>SERVICE DATA AND SPECIFICATIONS</b>		C
<b>4WD</b> .....	108	<b>(SDS)</b> .....	115	
4WD : Exploded View .....	109	General Specification .....	115	
4WD : Removal and Installation .....	109	Vehicle Speed When Shifting Gears .....	115	TM
4WD : Inspection .....	112	Stall Speed .....	115	
<b>DISASSEMBLY AND ASSEMBLY</b> .....	113	Line Pressure .....	115	
<b>TORQUE CONVERTER AND CONVERTER</b>		Solenoid Valves .....	116	E
<b>HOUSING OIL SEAL</b> .....	113	CVT Fluid Temperature Sensor .....	116	
Exploded View .....	113	Primary Speed Sensor .....	116	F
		Secondary Speed Sensor .....	116	
		Torque Converter .....	116	G
				H
				I
				J
				K
				L
				M
				N
				O
				P

# دیجیتال خودرو

شرکت دیجیتال خودرو سامانه (مسئولیت محدود)

اولین سامانه دیجیتال تعمیرکاران خودرو در ایران

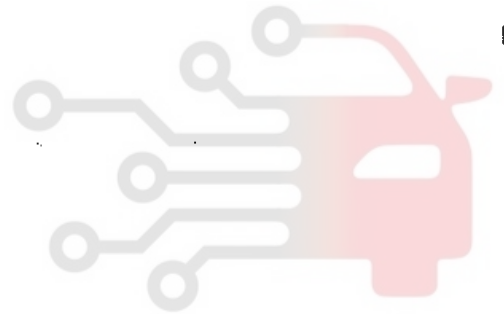

# BASIC INSPECTION

## DIAGNOSIS AND REPAIR WORK FLOW

### Work Flow

INFOID:000000004905137

### INTRODUCTION

The TCM receives signals from the vehicle speed sensor and PNP switch. Then it provides shift control or lock-up control via CVT solenoid valves.

The TCM also communicates with the ECM by means of signals sent from sensing elements used with the OBD-related parts of the CVT system for malfunction-diagnostic purposes. The TCM is capable of diagnosing malfunctioning parts while the ECM can store malfunctions in its memory. (With OBD)

Input and output signals must always be correct and stable in the operation of the CVT system. The CVT system must be in good operating condition and be free of valve seizure, solenoid valve malfunction, etc.

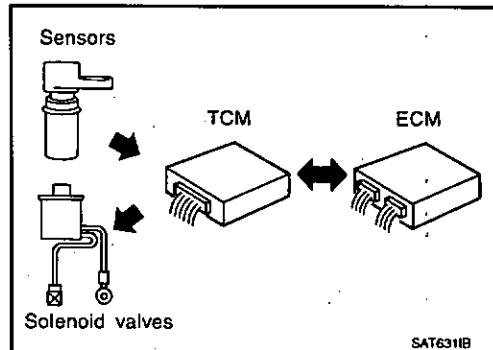

It is much more difficult to diagnose a malfunction that occurs intermittently rather than continuously. Most intermittent malfunctions are caused by poor electric connections or improper wiring. In this case, careful checking of suspected circuits may help prevent the replacement of good parts.

A visual check only may not find the cause of the malfunctions. A road test with a circuit tester connected should be performed.

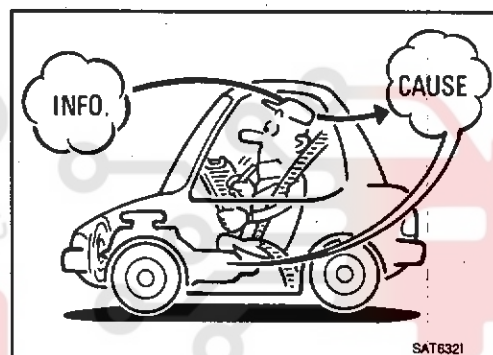

اولین سامانه دیجیتال تعمیرکاران خودرو در ایران

Before undertaking actual checks, take a few minutes to talk with a customer who approaches with a driveability complaint. The customer can supply good information about such malfunctions, especially intermittent ones. Find out what symptoms are present and under what conditions they occur. A "Diagnostic Work Sheet" as shown on the example (Refer to TM-4) should be used.

Start your diagnosis by looking for "conventional" malfunctions first. This will help troubleshoot driveability malfunctions on an electronically controlled engine vehicle.

Also check related Service Bulletins.

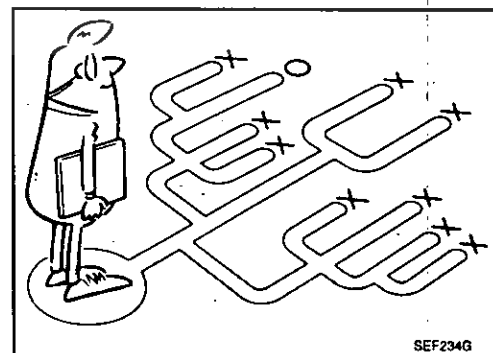

### Diagnostic Work Sheet

INFOID:000000004905138

### INFORMATION FROM CUSTOMER

#### KEY POINTS

- **WHAT**..... Vehicle & CVT model
- **WHEN**..... Date, Frequencies
- **WHERE**..... Road conditions
- **HOW**..... Operating conditions, Symptoms

Customer name	MR/MS	Model & Year	VIN
Trans. Model		Engine	Mileage
Malfunction Date		Manuf. Date	In Service Date

DIAGNOSIS AND REPAIR WORK FLOW

< BASIC INSPECTION >

[CVT: RE0F10A]

Frequency	<input type="checkbox"/> Continuous <input type="checkbox"/> Intermittent ( times a day)	
Symptoms	<input type="checkbox"/> Vehicle does not move. ( <input type="checkbox"/> Any position <input type="checkbox"/> Particular position)	
	<input type="checkbox"/> No shift	
	<input type="checkbox"/> Lock-up malfunction	
	<input type="checkbox"/> Shift shock or slip ( <input type="checkbox"/> N → D <input type="checkbox"/> N → R <input type="checkbox"/> Lock-up <input type="checkbox"/> Any drive position)	
	<input type="checkbox"/> Noise or vibration	
	<input type="checkbox"/> No pattern select	
	<input type="checkbox"/> Others ( )	
Malfunction Indicator Lamp (MIL)*	<input type="checkbox"/> Continuously lit	<input type="checkbox"/> Not lit

A  
B  
C  
TM

\*: With OBD

DIAGNOSTIC WORK SHEET

1	<input type="checkbox"/> Read the item on cautions concerning fail-safe and understand the customer's complaint.		TM-46
2	<input type="checkbox"/> CVT fluid inspection, stall test and line pressure test		
	<input type="checkbox"/> CVT fluid inspection		
		<input type="checkbox"/> Leak (Repair leak location.) <input type="checkbox"/> State <input type="checkbox"/> Amount	TM-65
	<input type="checkbox"/> Stall test		
		<input type="checkbox"/> Torque converter one-way clutch <input type="checkbox"/> Reverse brake <input type="checkbox"/> Forward clutch <input type="checkbox"/> Steel belt	<input type="checkbox"/> Engine <input type="checkbox"/> Line pressure low <input type="checkbox"/> Primary pulley <input type="checkbox"/> Secondary pulley
	<input type="checkbox"/> Line pressure inspection - Suspected part:		
3	<input type="checkbox"/> Perform road test.		TM-71
	3-1.	Check before engine is started	TM-71
	3-2.	Check at idle	TM-71
	3-3.	Cruise test	TM-72
	<input type="checkbox"/> Check malfunction phenomena to repair or replace malfunctioning part after completing all road tests. Refer to <u>TM-48</u> , " <u>Symptom Table</u> ".		
4	<input type="checkbox"/> Drive vehicle to check that the malfunction phenomenon has been resolved.		
5	<input type="checkbox"/> Erase the results of the self-diagnosis from the TCM and the ECM.		TM-36

E  
F  
G  
H  
I  
J  
K  
L  
M  
N  
O  
P

CVT SYSTEM

< FUNCTION DIAGNOSIS >

[CVT: RE0F10A]

FUNCTION DIAGNOSIS

CVT SYSTEM

System Diagram

INFOID:000000004905140

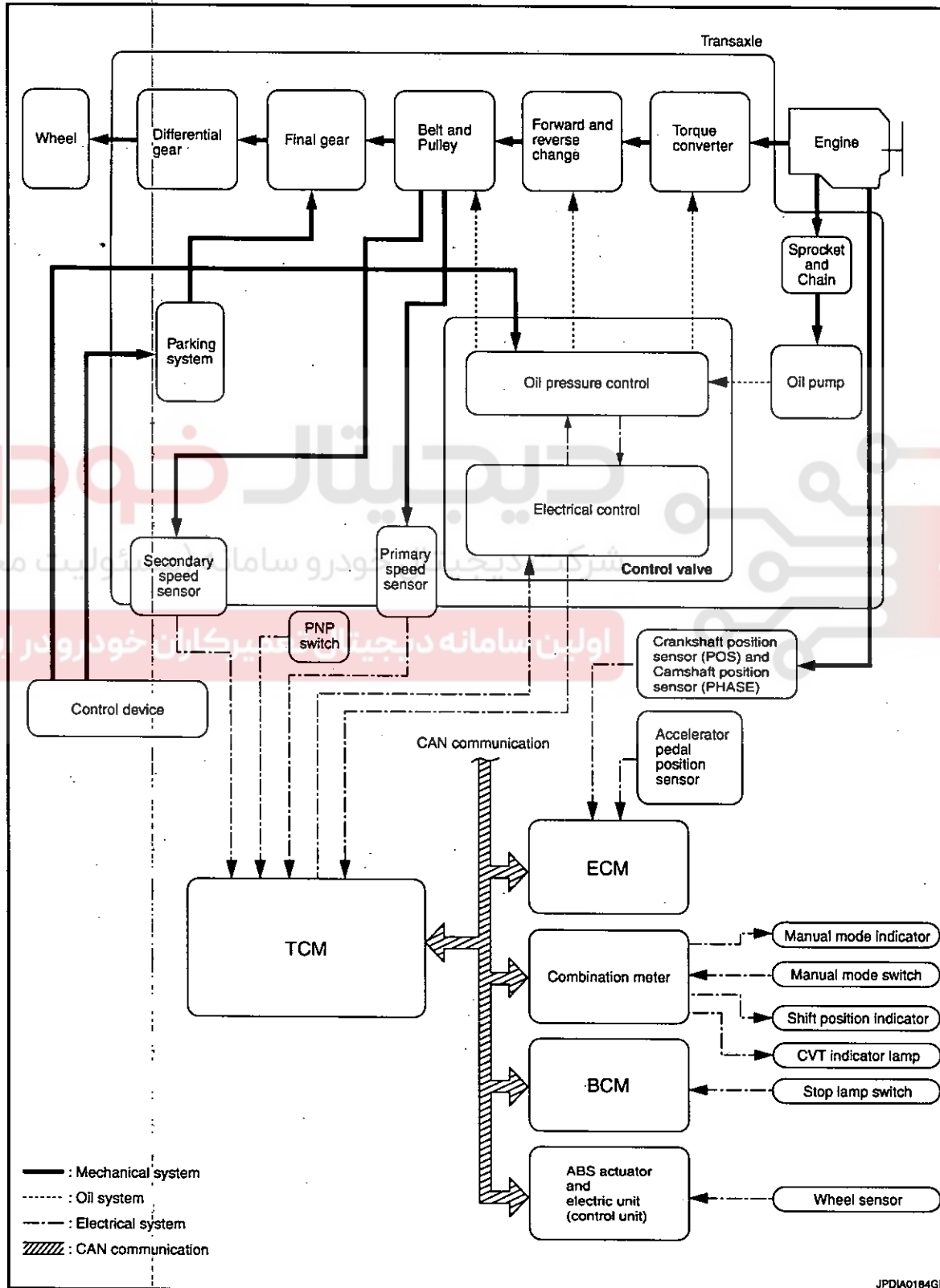

CVT SYSTEM

[CVT: RE0F10A]

< FUNCTION DIAGNOSIS >

Component Parts Location

INFOID:000000004905141

CAUTION:

This is applied to TCM parts number "31036 JD00A, 31036 JD02A, 31036 JD10A and 31036 JD12A".

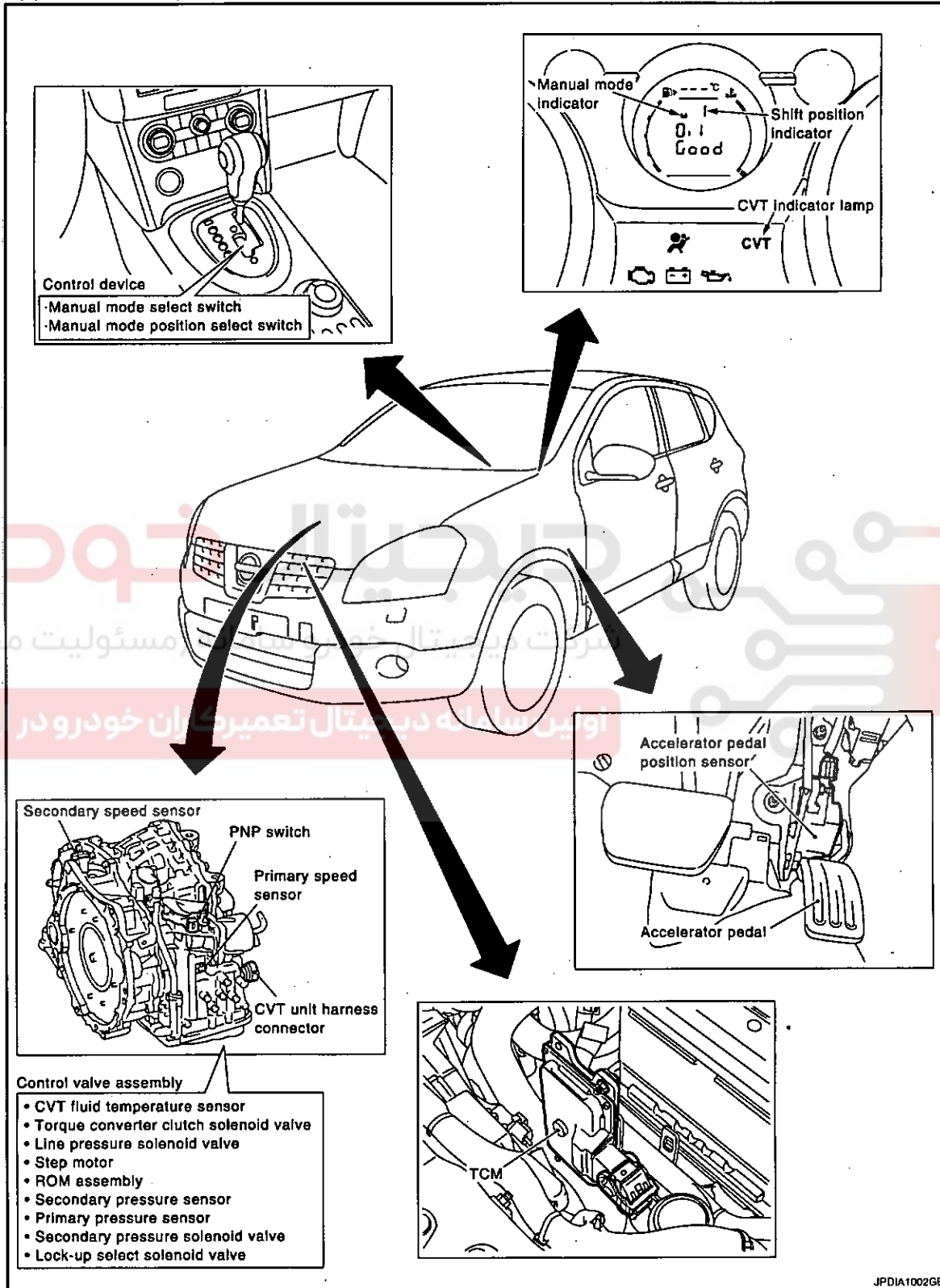

CAUTION:

JPDIA1002GB

A  
B  
C  
TM  
E  
F  
G  
H  
I  
J  
K  
L  
M  
N  
O  
P

CVT SYSTEM

< FUNCTION DIAGNOSIS >

[CVT: RE0F10A]

This is applied to TCM parts except number "31036 JD00A, 31036 JD02A, 31036 JD10A and 31036 JD12A".

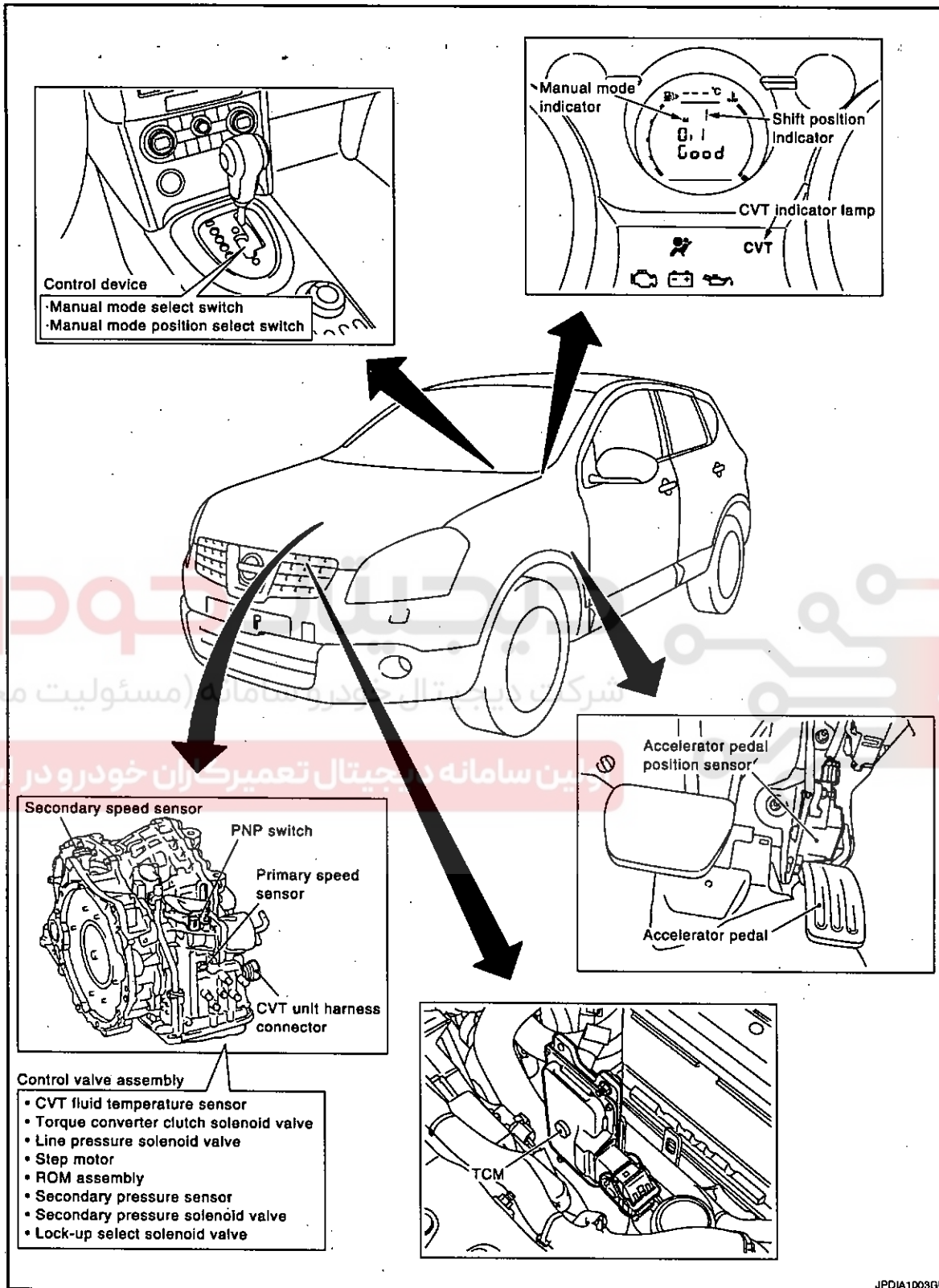



MECHANICAL SYSTEM

Cross-Sectional View

INFOID:000000004905142

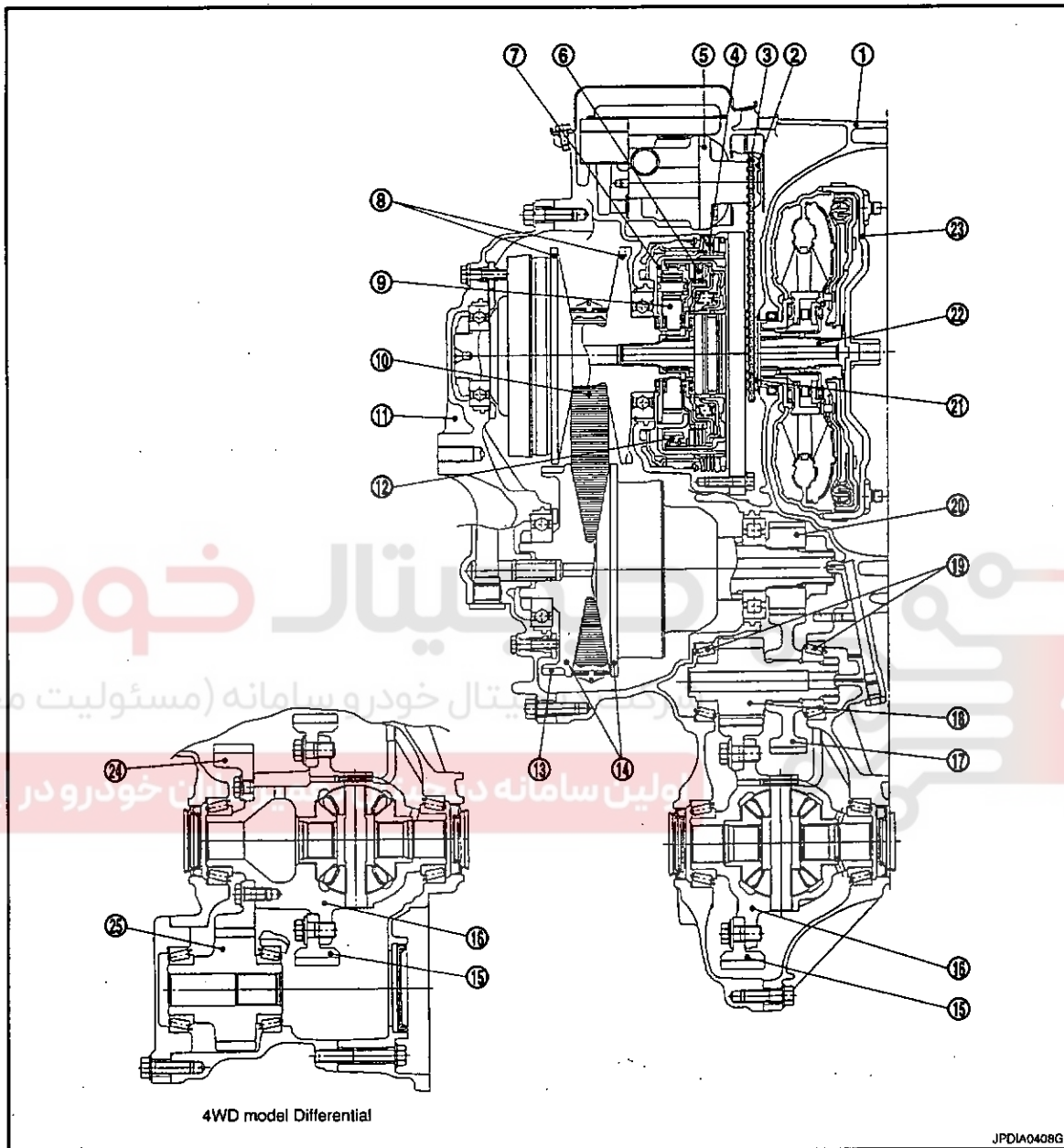

A  
B  
C  
TM  
E  
F  
G  
H  
I  
J  
K  
L  
M  
N  
O  
P

- |                          |                      |                      |
|--------------------------|----------------------|----------------------|
| 1. Converter housing     | 2. Driven sprocket   | 3. Chain             |
| 4. Reverse brake         | 5. Oil pump          | 6. Forward clutch    |
| 7. Planetary carrier     | 8. Primary pulley    | 9. Sun gear          |
| 10. Steel belt           | 11. Side cover       | 12. Internal gear    |
| 13. Parking gear         | 14. Secondary pulley | 15. Final gear       |
| 16. Differential case    | 17. Idler gear       | 18. Reduction gear   |
| 19. Taper roller bearing | 20. Output gear      | 21. Drive sprocket   |
| 22. Input shaft          | 23. Torque converter | 24. Drive trans gear |
| 25. Ring trans gear      |                      |                      |

System Diagram

INFOID:000000004905143

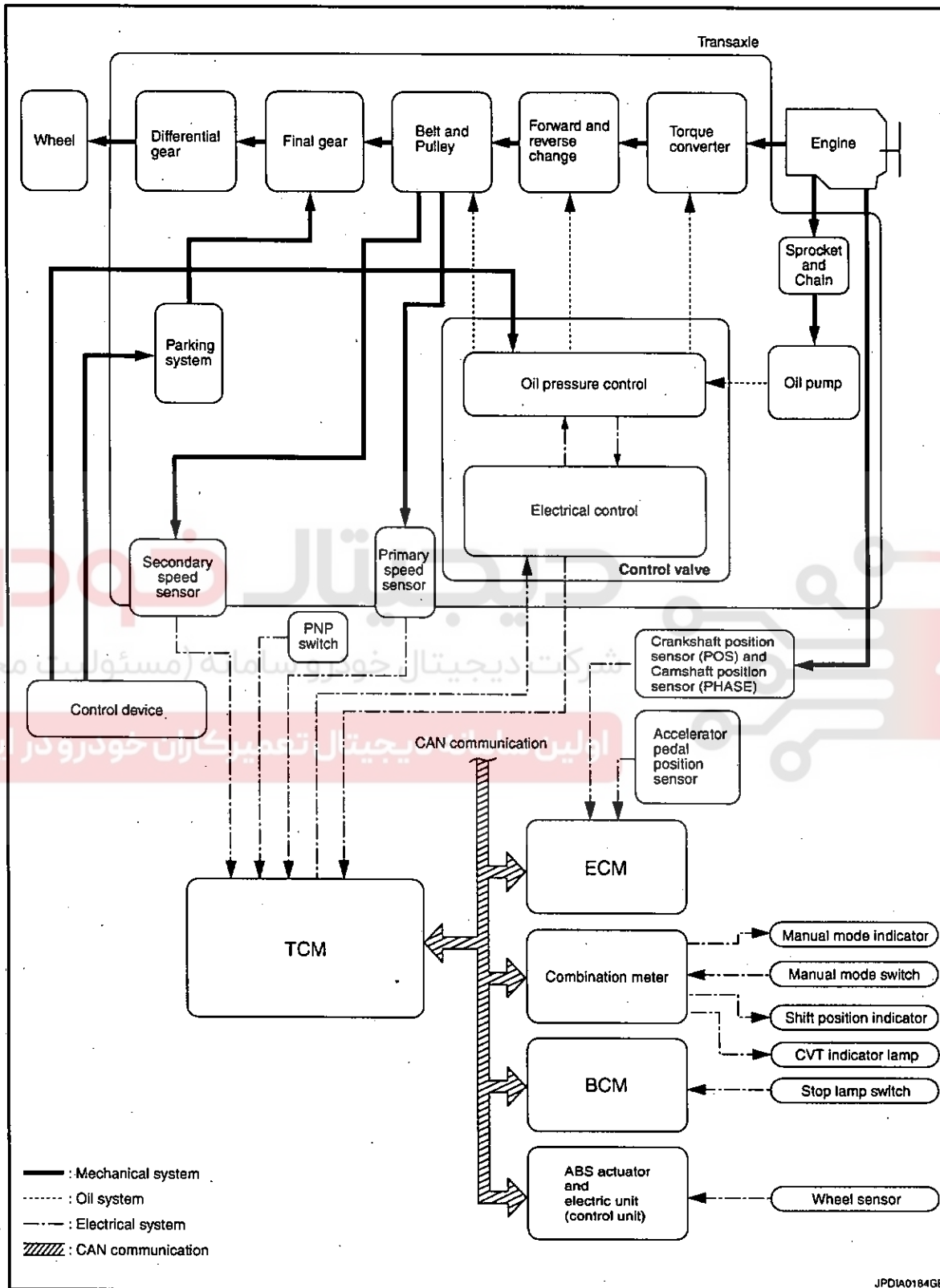

System Description

INFOID:000000004905144

Transmits the power from the engine to the drive wheel.

Component Parts Location

INFOID:000000004905145

A  
B  
C  
TM  
E  
F  
G  
H  
I  
J  
K  
L  
M  
N  
O  
P

CAUTION:

This is applied to TCM parts number "31036 JD00A, 31036 JD02A, 31036 JD10A and 31036 JD12A".

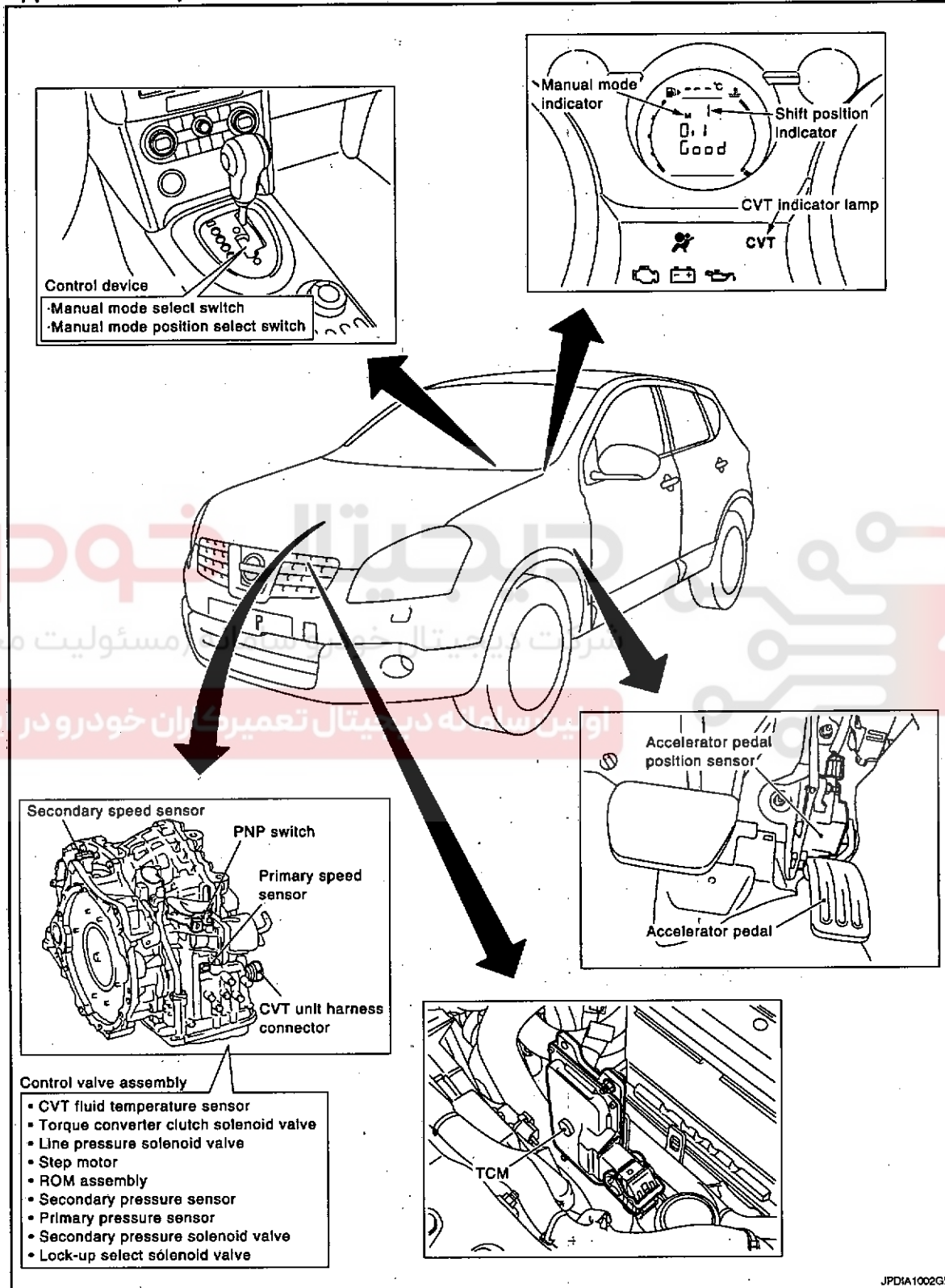

CAUTION:

JPDIA1002GB

MECHANICAL SYSTEM

< FUNCTION DIAGNOSIS >

[CVT: RE0F10A]

This is applied to TCM parts except number "31036 JD00A, 31036 JD02A, 31036 JD10A and 31036 JD12A".

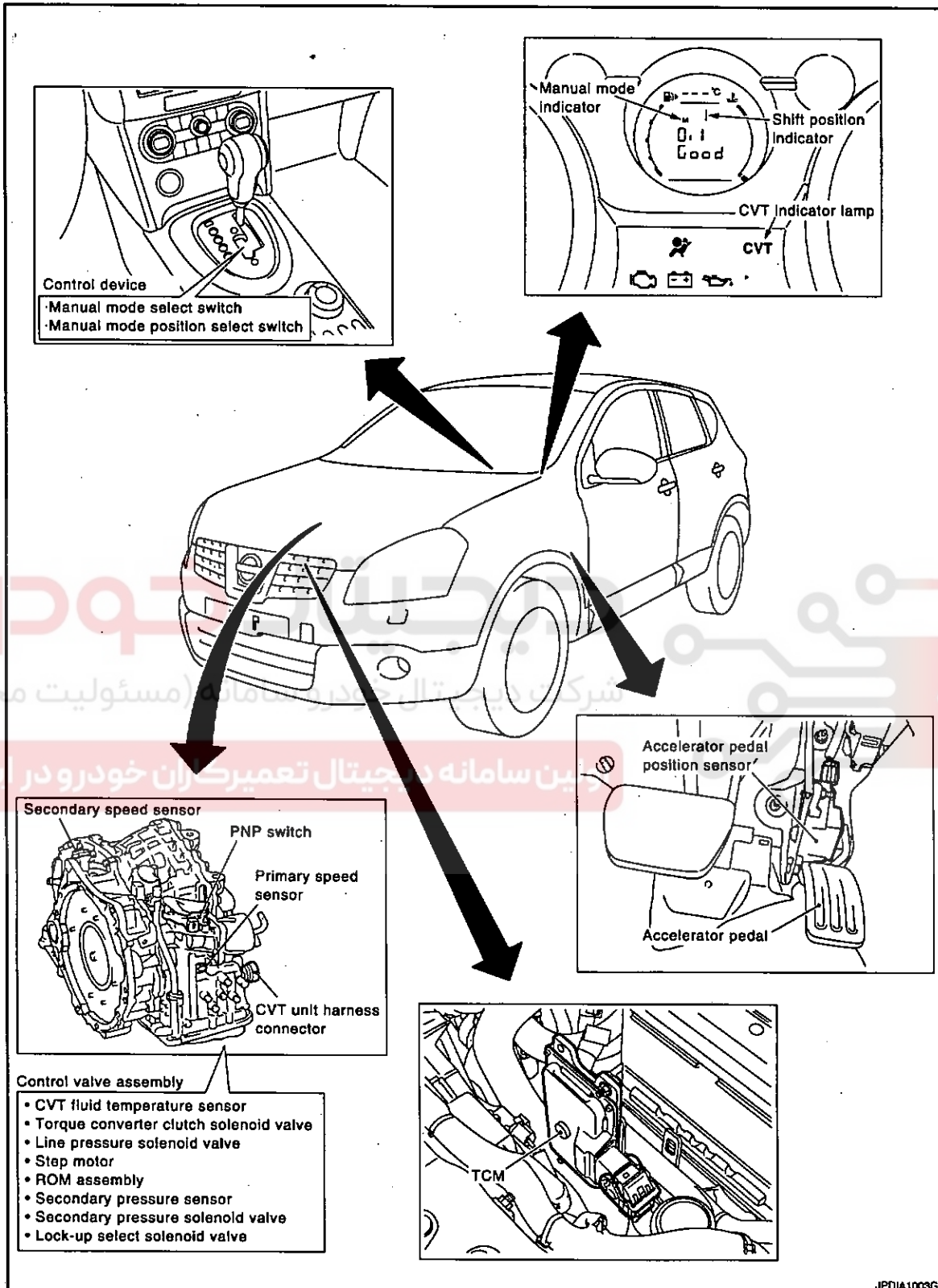

Component Description

INFOID:000000004905146

## MECHANICAL SYSTEM

&lt; FUNCTION DIAGNOSIS &gt;

[CVT: RE0F10A]

Item	Function		
Torque converter	The torque converter is the device that increases the engine torque as well as the conventional CVT and transmits it to the transaxle.	A	
Oil pump	The efficiency of pump discharge rate has been increased at low-rpm and optimized at high-rpm by adopting a vane-type oil pump controlled by the engine. Discharged oil from oil pump is transmitted to the control valve. It is used as the oil of primary and secondary pulley operation and the oil of clutch operation and the lubricant for each part.	B C	
Planetary gear	Perform the transmission of drive power and the switching of forward/backward movement.	TM	
Forward clutch			
Reverse brake			
Primary pulley	It is composed of a pair of pulleys (the groove width is changed freely in the axial direction) and the steel belt (the steel star wheels are placed continuously and the belt is guided with the multilayer steel rings on both sides). The groove width changes according to wrapping radius of steel belt and pulley from low status to overdrive status continuously with non-step. It is controlled with the oil pressures of primary pulley and secondary pulley.	E F	
Secondary pulley			
Steel belt			
2WD	Output gear	Reduction gear consists of primary deceleration (output gear and idler gear in pair) and secondary deceleration (reduction gear and final gear in pair). Each of them uses a helical gear.	G H
	Idler gear		
	Reduction gear		
	Final gear		
	Differential		
4WD	Output gear	Variable speed gear consists of primary deceleration (output gear and idler gear in pair), secondary deceleration (reduction gear and final gear in pair), and acceleration (drive trans gear and ring trans gear in pair). Each of them uses a helical gear.	I J
	Idler gear		
	Reduction gear		
	Final gear		
	Differential		
	Ring trans gear		
Manual shaft	The parking rod rotates the parking pole and the parking pole engages with the parking gear when the manual shaft is in "P" position. As a result the parking gear and the output axis are fixed.	K L M N O P	
Parking rod			
Parking pawl			
Parking gear			

HYDRAULIC CONTROL SYSTEM

System Diagram

INFOID:000000004905147

CAUTION:

This is applied to TCM parts number "31036 JD00A, 31036 JD02A, 31036 JD10A and 31036 JD12A".

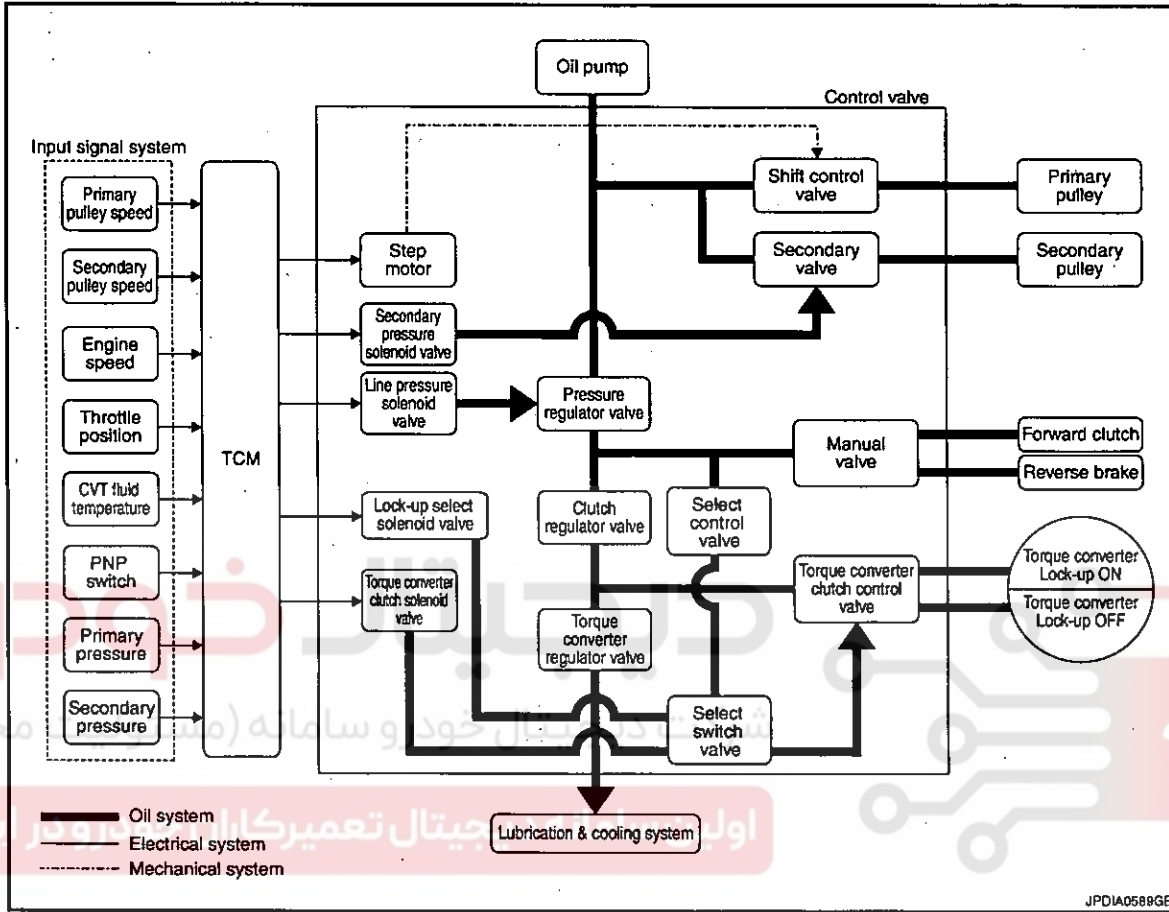

CAUTION:

HYDRAULIC CONTROL SYSTEM

< FUNCTION DIAGNOSIS >

[CVT: RE0F10A]

This is applied to TCM parts except number "31036 JD00A, 31036 JD02A, 31036 JD10A and 31036 JD12A".

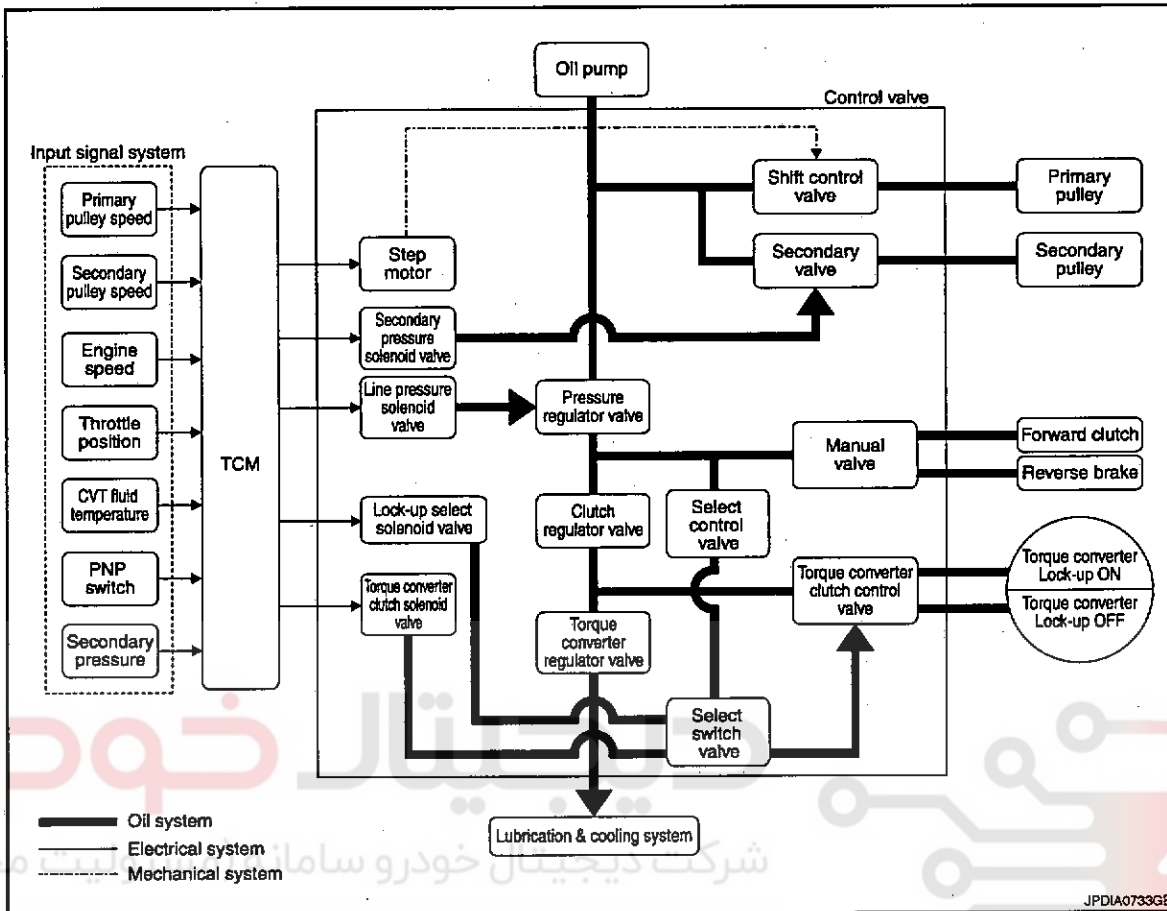

System Description

The hydraulic control mechanism consists of the oil pump directly driven by the engine, the hydraulic control valve that controls line pressure and transmission, and the input signal line.

LINE PRESSURE AND SECONDARY PRESSURE CONTROL

- When an input torque signal equivalent to the engine driving force is transmitted from the ECM to the TCM, the TCM controls the line pressure solenoid valve and secondary pressure solenoid valve.
- Line pressure solenoid valve activates pressure regulator valve, and line pressure from oil pump is adjusted for the optimum driving condition. Secondary pressure is controlled by lowering line pressure.

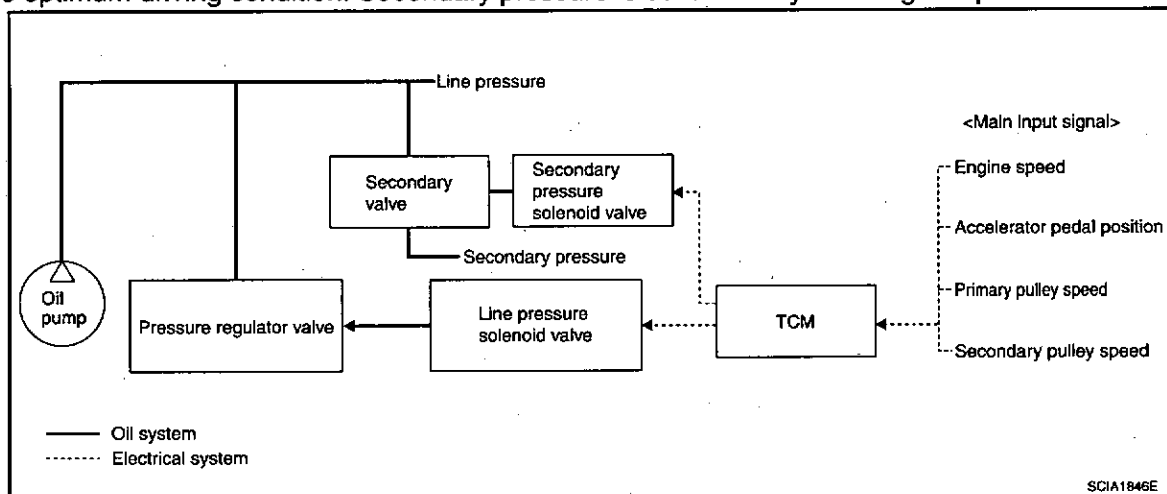

Normal Control

Optimize the line pressure and secondary pressure, depending on driving conditions, on the basis of the throttle position, the engine speed, the primary pulley (input) revolution speed, the secondary pulley (output) revo-

## HYDRAULIC CONTROL SYSTEM

&lt; FUNCTION DIAGNOSIS &gt;

[CVT: RE0F10A]

lution speed, the brake signal, the PNP switch signal, the lock-up signal, the voltage, the target gear ratio, the fluid temperature, and the fluid pressure.

## Feedback Control

For the normal fluid control and the select fluid control, secondary pressure is detected for feedback control by using a secondary pressure sensor to set a high-precision secondary pressure.

## Component Parts Location

INFOID:000000004905149

## CAUTION:

# دیجیتال خودرو

شرکت دیجیتال خودرو سامانه (مسئولیت محدود)

اولین سامانه دیجیتال تعمیرکاران خودرو در ایران

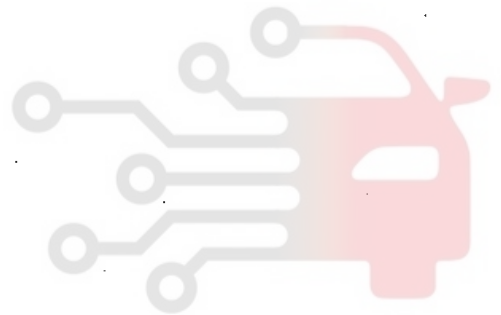



HYDRAULIC CONTROL SYSTEM

< FUNCTION DIAGNOSIS >

[CVT: RE0F10A]

This is applied to TCM parts number "31036 JD00A, 31036 JD02A, 31036 JD10A and 31036 JD12A".

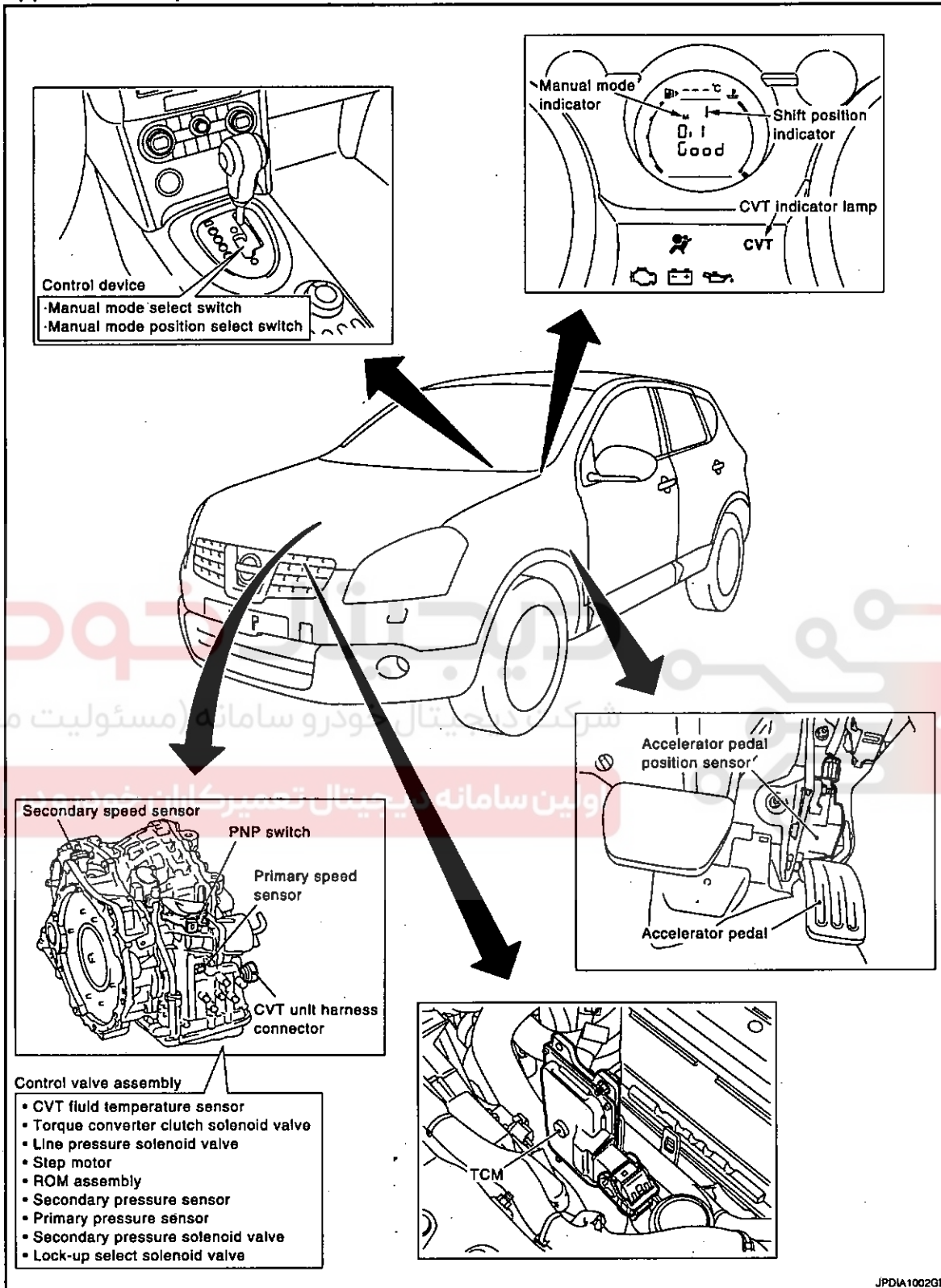

CAUTION:

JPDIA1002GB

A  
B  
C  
TM  
E  
F  
G  
H  
I  
J  
K  
L  
M  
N  
O  
P

HYDRAULIC CONTROL SYSTEM

< FUNCTION DIAGNOSIS >

[CVT: RE0F10A]

This is applied to TCM parts except number "31036 JD00A, 31036 JD02A, 31036 JD10A and 31036 JD12A".

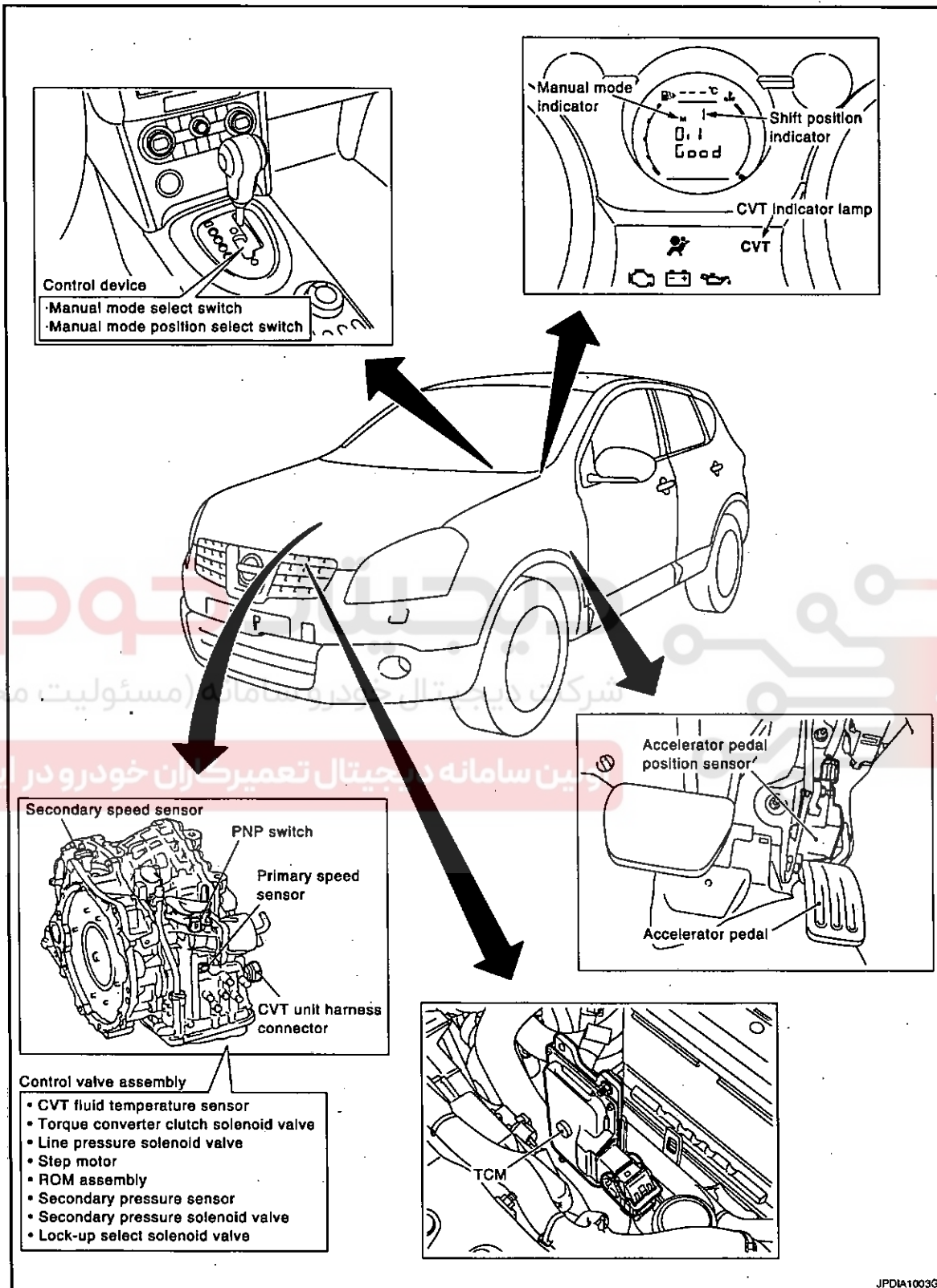

Component Description

INFOID:000000004905150

TRANSAXLE ASSEMBLY

## HYDRAULIC CONTROL SYSTEM

&lt; FUNCTION DIAGNOSIS &gt;

[CVT: RE0F10A]

Name	Function	
Torque converter regulator valve	Optimizes the supply pressure for the torque converter depending on driving conditions.	A
Pressure regulator valve	Optimizes the discharge pressure from the oil pump depending on driving conditions.	B
TCC control valve	<ul style="list-style-type: none"> <li>Activates or deactivates the lock-up.</li> <li>Locks-up smoothly by opening lock-up operation excessively.</li> </ul>	B
Shift control valve	Controls inflow/outflow of line pressure from the primary pulley depending on the stroke difference between the stepping motor and the primary pulley.	C
Secondary valve	Controls the line pressure from the secondary pulley depending on operating conditions.	
Clutch regulator valve	Adjusts the clutch operating pressure depending on operating conditions.	TM
Manual valve	Transmits the clutch operating pressure to each circuit in accordance with the selected position.	
Select control valve	Engages forward clutch, reverse brake smoothly depending on select operation.	E
Select switch valve	The select switch valve enables to select engagement/disengagement of lock-up clutch and that of forward clutch and reverse clutch.	
TCC solenoid valve	<ul style="list-style-type: none"> <li>The torque converter clutch solenoid valve is activated by the TCM in response to signals sent from the vehicle speed and accelerator pedal position sensors. Lock-up piston operation will then be controlled.</li> <li>Lock-up operation, however, is prohibited when CVT fluid temperature is too low.</li> <li>When the accelerator pedal is depressed (less than 2.0/8) in lock-up condition, the engine speed shall not change abruptly. If there is a big jump in engine speed, there is no lock-up.</li> </ul>	F G
Secondary pressure solenoid valve	The pressure control solenoid valve B (secondary pressure solenoid valve) regulates the oil pump discharge pressure to suit the driving condition in response to the signal sent from the TCM.	H
Line pressure solenoid valve	The pressure control solenoid valve A (line pressure solenoid valve) regulates the oil pump discharge pressure to suit the driving condition in response to the signal transmitted from the TCM.	I
Step motor	The step motor changes the step by turning 4 coils ON/OFF according to the signal from TCM. As a result, the flow of line pressure to primary pulley is changed and pulley ratio is controlled.	J
Lock-up select solenoid valve	<ul style="list-style-type: none"> <li>The lock-up select solenoid valve controls lock-up clutch pressure or forward clutch pressure (reverse brake pressure).</li> <li>When controlling lock-up clutch, the valve is turned OFF. When controlling forward clutch, it is turned ON.</li> </ul>	K
Primary speed sensor	The input speed sensor (primary speed sensor) detects the primary pulley revolution speed and sends the signal to the TCM.	L
Secondary speed sensor	The vehicle speed sensor CVT [output speed sensor (secondary speed sensor)] detects the revolution of the CVT output shaft and emits a pulse signal. The pulse signal is transmitted to the TCM, which converts it into vehicle speed.	M
PNP switch	The PNP switch detects the selector lever position and sends a signal to the TCM.	
Primary pulley	TM-12	N
Secondary pulley		
Forward clutch		
Torque converter		O

## EXCEPT TRANSAXLE ASSEMBLY

Name	Function	
TCM	Judges the vehicle driving status according to the signal from each sensor and controls the non-step transmission mechanism properly.	P
Accelerator pedal position sensor	The electric throttle control actuator consists of throttle control motor, accelerator pedal position sensor, throttle position sensor, etc. The actuator sends the signal to the ECM, and ECM sends the signal to TCM via CAN communication.	

CONTROL SYSTEM

< FUNCTION DIAGNOSIS >

[CVT: RE0F10A]

CONTROL SYSTEM

System Diagram

INFOID:000000004905151

CAUTION:

This is applied to TCM parts number "31036 JD00A, 31036 JD02A, 31036 JD10A and 31036 JD12A".

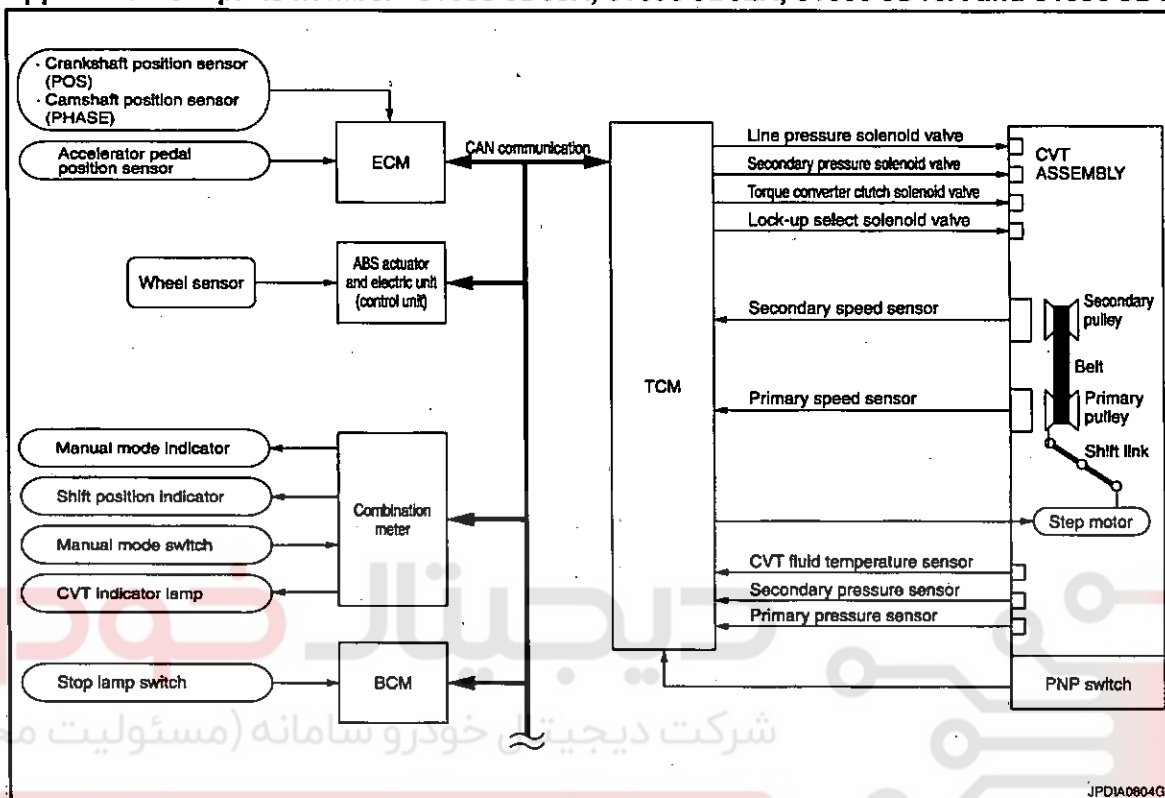

CAUTION:

This is applied to TCM parts except number "31036 JD00A, 31036 JD02A, 31036 JD10A and 31036 JD12A".

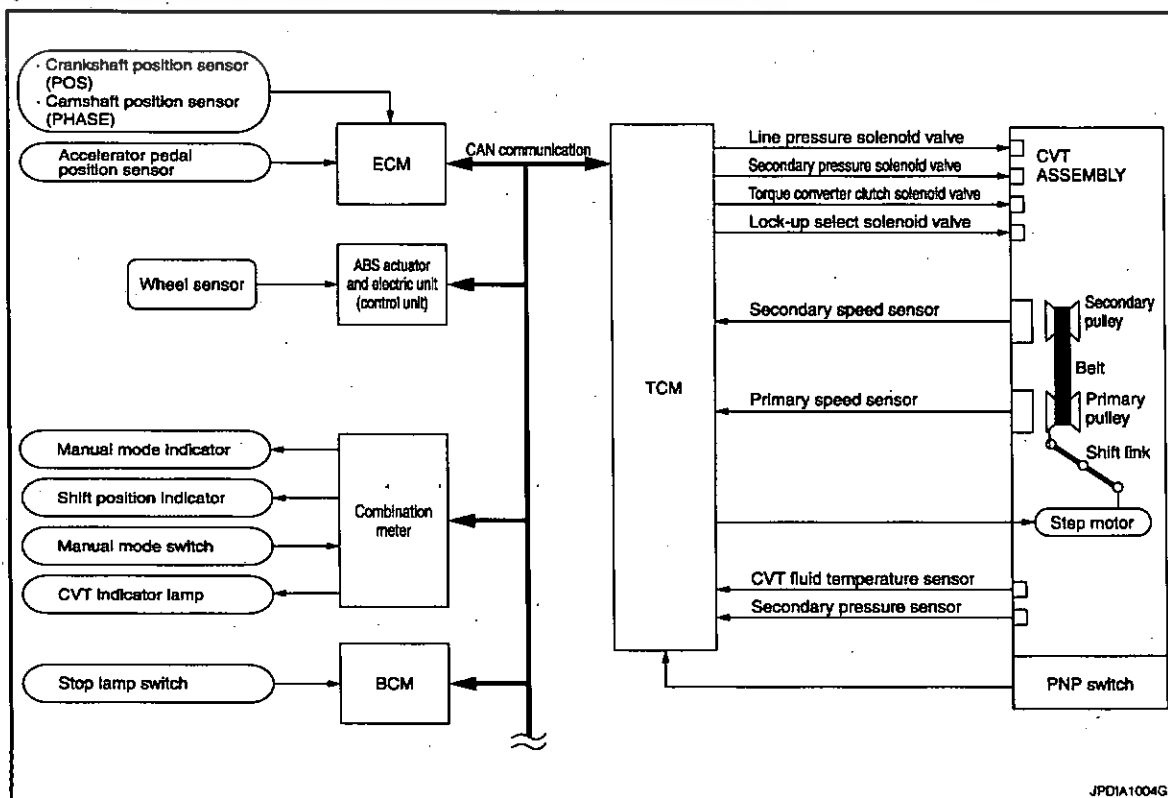

CONTROL SYSTEM

< FUNCTION DIAGNOSIS >

[CVT: RE0F10A]

System Description

INFOID:000000004905152

The CVT senses vehicle operating conditions through various sensors. It always controls the optimum shift position and reduces shifting and lock-up shocks.

TCM FUNCTION

The function of the TCM is to:

- Receive input signals sent from various switches and sensors.
- Determine required line pressure, shifting point, and lock-up operation.
- Send required output signals to the step motor and the respective solenoids.

SENSORS (or SIGNAL)		TCM		ACTUATORS
PNP switch Accelerator pedal position signal Closed throttle position signal Engine speed signal CVT fluid temperature sensor Vehicle speed signal Manual mode signal Stop lamp switch signal Primary speed sensor Secondary speed sensor Primary pressure sensor* Secondary pressure sensor	⇒	Shift control Line pressure control Primary pressure control Secondary pressure control Lock-up control Engine brake control Vehicle speed control Fail-safe control Self-diagnosis Duet-EA control CAN system On board diagnosis	⇒	Step motor Torque converter clutch solenoid valve Lock-up select solenoid valve Line pressure solenoid valve Secondary pressure solenoid valve Manual mode indicator Shift position indicator

\*: This item is applied to TCM parts number "31036 JD00A, 31036 JD02A, 31036 JD10A and 31036 JD12A".

INPUT/OUTPUT SIGNAL OF TCM

Control item	Fluid pressure control	Select control	Shift control	Lock-up control	CAN communication control	Fail-safe function <sup>2</sup>
PNP switch	X	X	X	X	X	X
Accelerator pedal position signal <sup>1</sup>	X	X	X	X	X	X
Closed throttle position signal <sup>1</sup>	X		X	X	X	
Engine speed signal <sup>1</sup>	X	X		X	X	X
CVT fluid temperature sensor	X	X	X	X		X
Manual mode signal <sup>1</sup>	X		X	X	X	X
Stop lamp switch signal <sup>1</sup>	X		X	X	X	
Primary speed sensor	X		X	X	X	X
Secondary speed sensor	X	X	X	X	X	X
Primary pressure sensor <sup>3</sup>	X		X			
Secondary pressure sensor	X		X			X
Step motor			X			X
TCC solenoid valve		X		X		X
Lock-up select solenoid valve		X		X		X
Line pressure solenoid valve	X	X	X			X
Secondary pressure solenoid valve	X		X			X

\*1: Input by CAN communications.

\*2: If these input and output signals are different, the TCM triggers the fail-safe function.

\*3: This item is applied to TCM parts number "31036 JD00A, 31036 JD02A, 31036 JD10A and 31036 JD12A".

Component Parts Location

INFOID:000000004905153

CAUTION:

CONTROL SYSTEM

< FUNCTION DIAGNOSIS >

[CVT: RE0F10A]

This is applied to TCM parts number "31036 JD00A, 31036 JD02A, 31036 JD10A and 31036 JD12A".

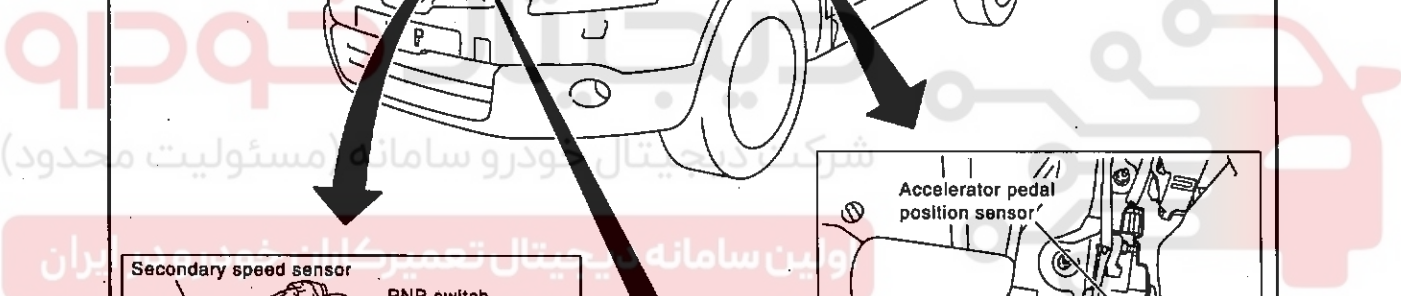
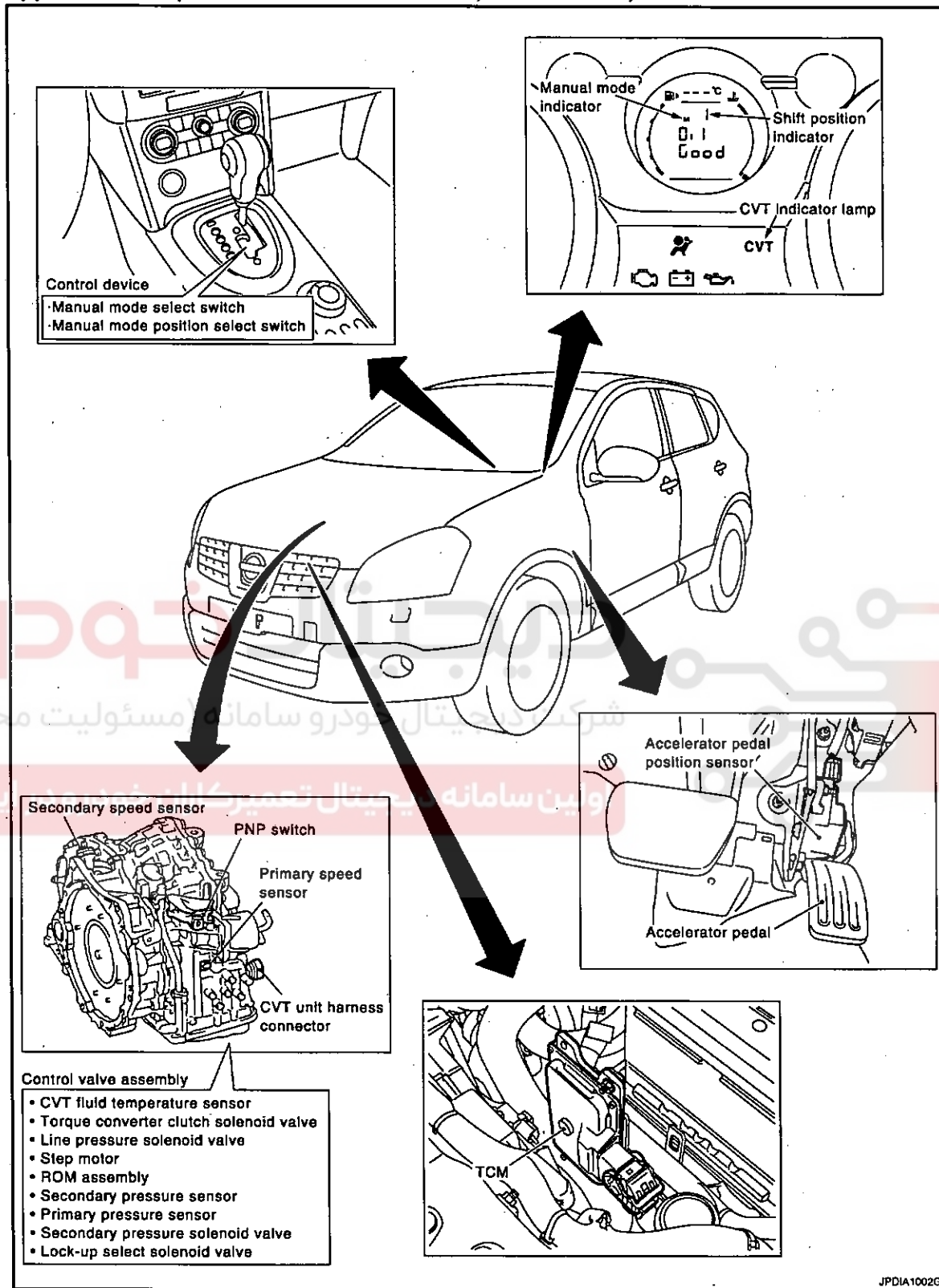

CAUTION:

JPDIA1002GB

CONTROL SYSTEM

< FUNCTION DIAGNOSIS >

[CVT: RE0F10A]

This is applied to TCM parts except number "31036 JD00A, 31036 JD02A, 31036 JD10A and 31036 JD12A".

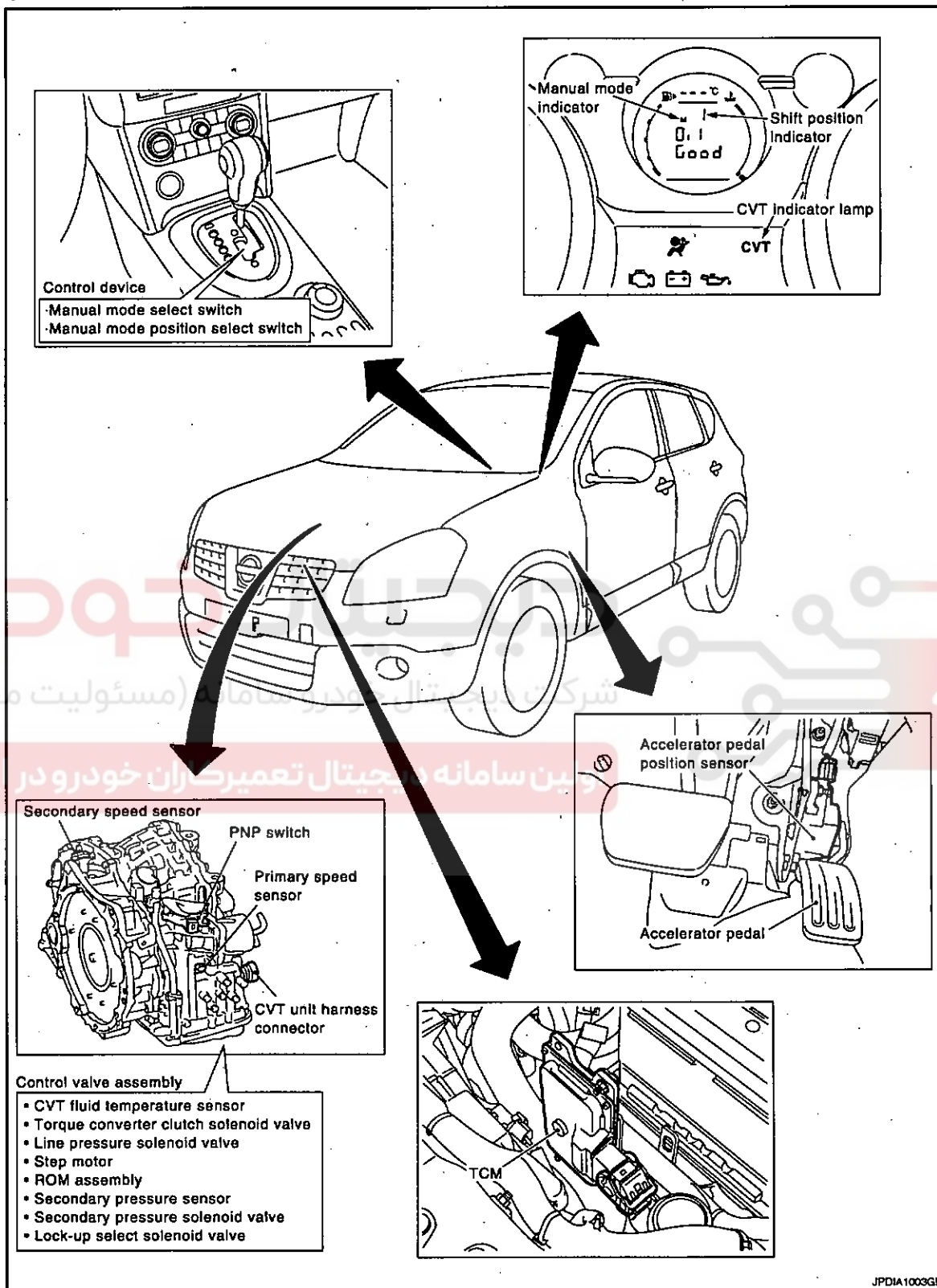

A  
B  
C  
TM  
E  
F  
G  
H  
I  
J  
K  
L  
M  
N  
O  
P

Component Description

INFOID:000000004905154

TRANSAXLE ASSEMBLY

## CONTROL SYSTEM

&lt; FUNCTION DIAGNOSIS &gt;

[CVT: RE0F10A]

Name	Function
CVT fluid temperature sensor	The CVT fluid temperature sensor detects the CVT fluid temperature and sends the signal to the TCM.
Secondary pressure sensor	The transmission fluid pressure sensor A (secondary pressure sensor) detects secondary pressure of CVT and sends the signal to the TCM.
PNP switch	TM-18
Primary speed sensor	
Secondary speed sensor	
Primary pressure sensor*	
Step motor	
TCC solenoid valve	
Lock-up select solenoid valve	
Line pressure solenoid valve	
Secondary pressure solenoid valve	

\*: This item is applied to TCM parts number "31036 JD00A, 31036 JD02A, 31036 JD10A and 31036 JD12A".

## EXCEPT TRANSAXLE ASSEMBLY

Name	Function
TCM	Optimally controls continuously variable transmission system by judging driving conditions based on signals from each sensor.
Stop lamp switch	BCM detects ON/OFF state of the stop lamp switch and transmits the data to the CVT control unit via CAN communication by converting the data to a signal.

شرکت دیجیتال خودرو سامانه (مسئولیت محدود)

اولین سامانه دیجیتال تعمیرکاران خودرو در ایران

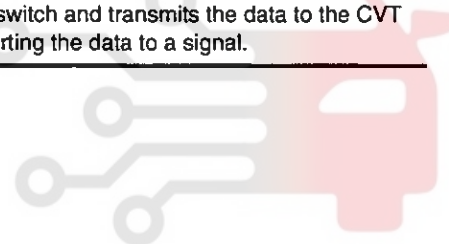



LOCK-UP AND SELECT CONTROL SYSTEM

< FUNCTION DIAGNOSIS >

[CVT: RE0F10A]

LOCK-UP AND SELECT CONTROL SYSTEM

System Diagram

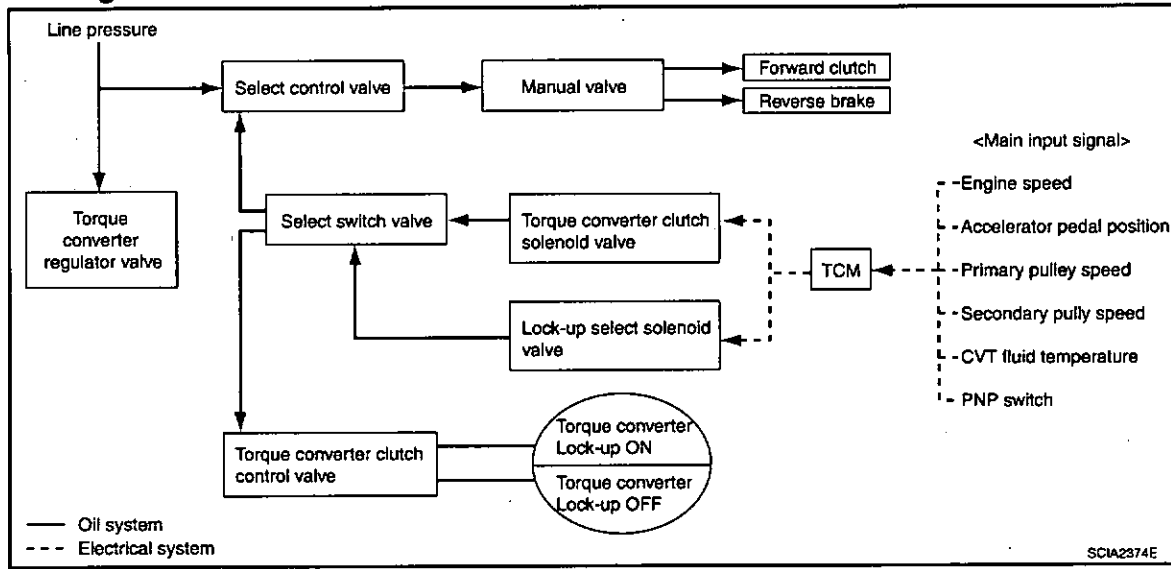

System Description

- The torque converter clutch piston in the torque converter is engaged to eliminate torque converter slip to increase power transmission efficiency.
- The torque converter clutch control valve operation is controlled by the torque converter clutch solenoid valve, which is controlled by a signal from TCM. The torque converter clutch control valve engages or releases the torque converter clutch piston.
- When shifting between "N" ("P") ⇒ "D" ("R"), torque converter clutch solenoid valve controls engagement power of forward clutch and reverse brake.
- The lock-up applied gear range was expanded by locking up the torque converter at a lower vehicle speed than AT models.

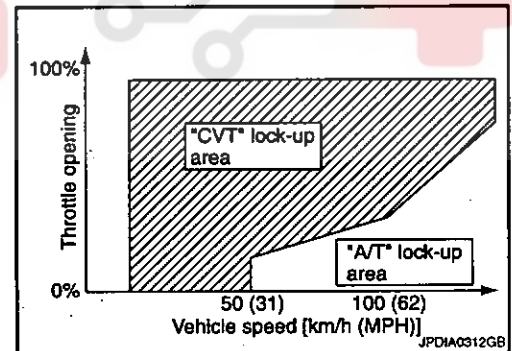

TORQUE CONVERTER CLUTCH AND SELECT CONTROL VALVE CONTROL

Lock-up Released

In the lock-up released state, the torque converter clutch control valve is set into the unlocked state by the torque converter clutch solenoid valve and the lock-up apply pressure is drained. In this way, the torque converter clutch piston is not coupled.

Lock-up Applied

In the lock-up applied state, the torque converter clutch control valve is set into the locked state by the torque converter clutch solenoid valve and lock-up apply pressure is generated. In this way, the torque converter clutch piston is pressed and coupled.

Select Control

When shifting between "N" ("P") ⇒ "D" ("R"), optimize the operating pressure on the basis of the throttle position, the engine speed, and the secondary pulley (output) revolution speed to lessen the shift shock.

Component Parts Location

CAUTION:

LOCK-UP AND SELECT CONTROL SYSTEM

< FUNCTION DIAGNOSIS >

[CVT: RE0F10A]

This is applied to TCM parts number "31036 JD00A, 31036 JD02A, 31036 JD10A and 31036 JD12A".

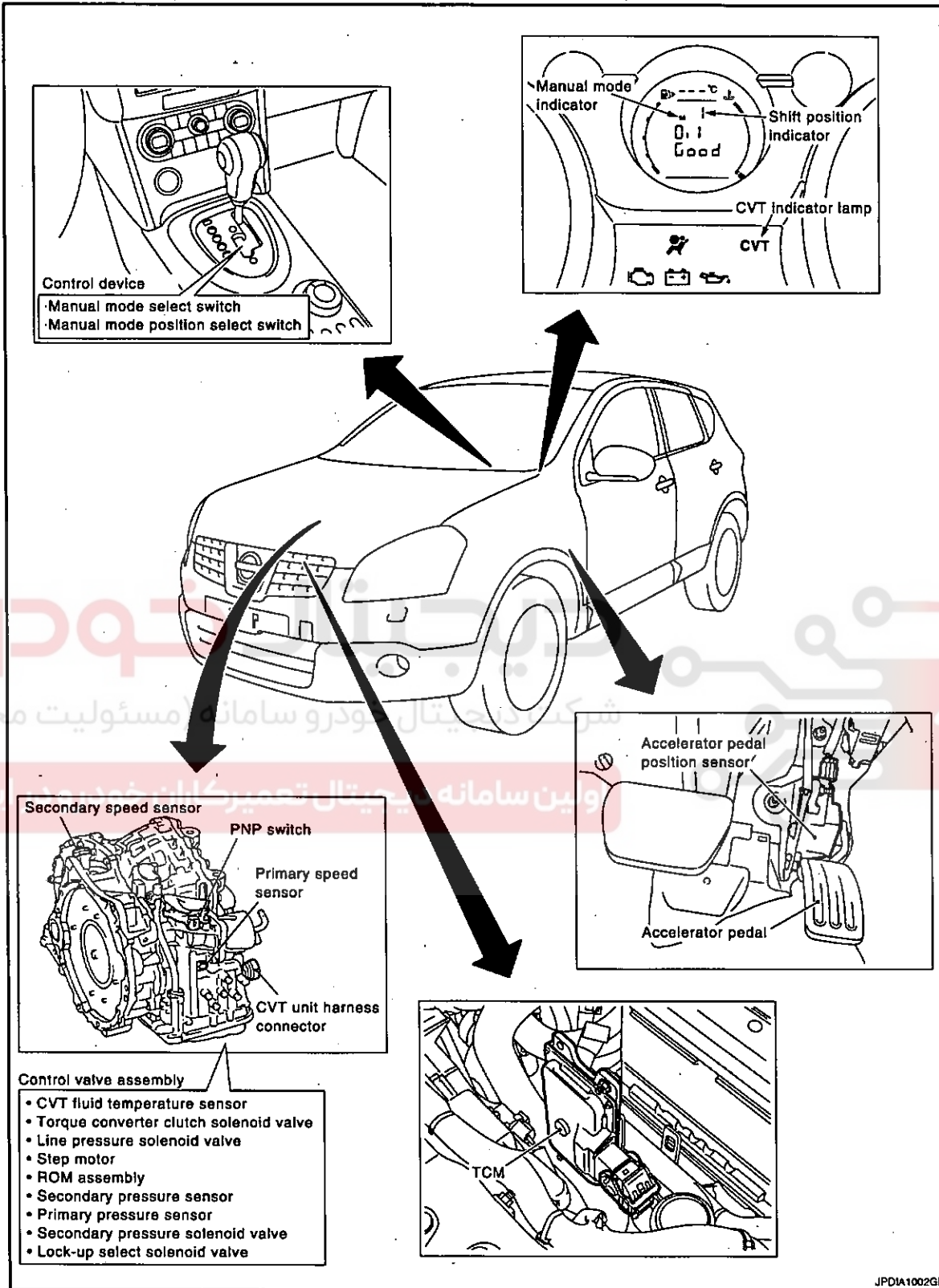

JPDIA1002GB

CAUTION:

LOCK-UP AND SELECT CONTROL SYSTEM

[CVT: RE0F10A]

< FUNCTION DIAGNOSIS >

This is applied to TCM parts except number "31036 JD00A, 31036 JD02A, 31036 JD10A and 31036 JD12A".

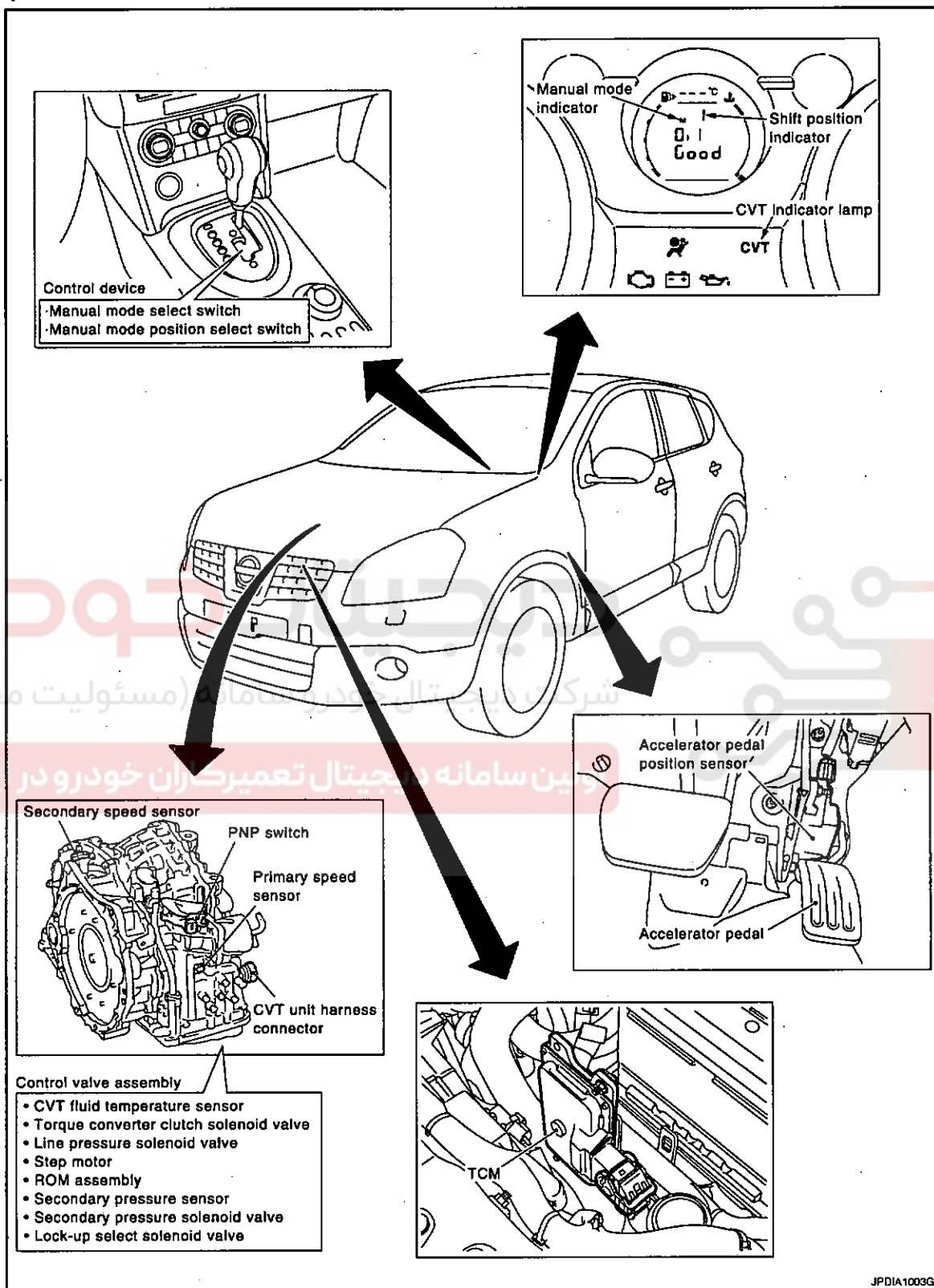

JPDIA1003GB

Component Description

INFOID:000000004905158

TRANSAXLE ASSEMBLY

A  
B  
C  
TM  
E  
F  
G  
H  
I  
J  
K  
L  
M  
N  
O  
P

## LOCK-UP AND SELECT CONTROL SYSTEM

&lt; FUNCTION DIAGNOSIS &gt;

[CVT: RE0F10A]

Name	Function
Torque converter regulator valve	TM-18
TCC control valve	
Select control valve	
Select switch valve	
Manual valve	
TCC solenoid valve	
Lock-up select solenoid valve	
Primary speed sensor	
Secondary speed sensor	
PNP switch	
CVT fluid temperature sensor	TM-23
Forward clutch	TM-12
Reverse brake	
Torque converter	

## EXCEPT TRANSAXLE ASSEMBLY

Name	Function
TCM	TM-23
Accelerator pedal position sensor	TM-18

شرکت دیجیتال خودرو (مسئولیت محدود)

اولین سامانه دیجیتال تعمیرکاران خودرو در ایران

SHIFT CONTROL SYSTEM

System Diagram

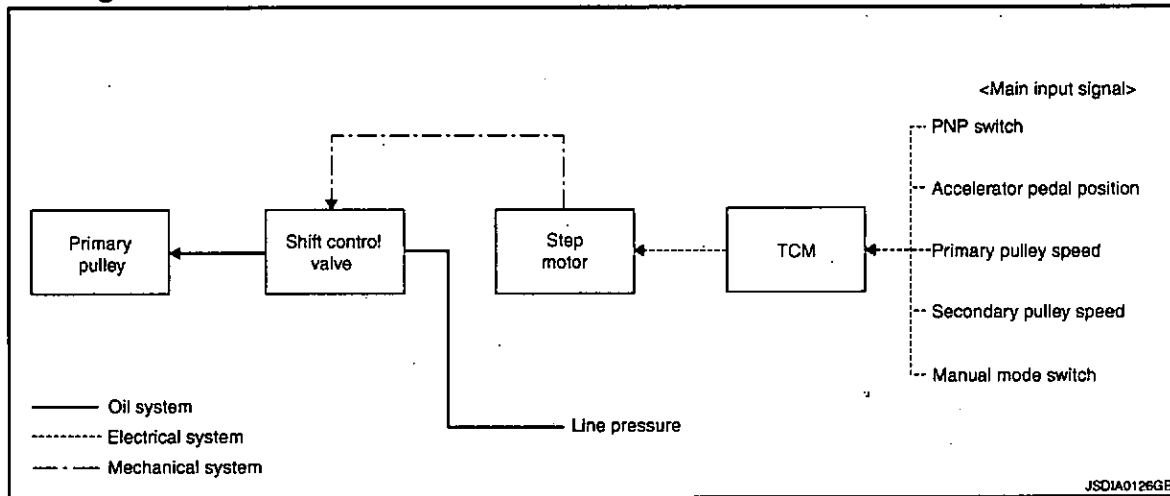

NOTE:

The gear ratio is set for each position separately.

System Description

INFOID:000000004905160

In order to select the gear ratio that can obtain the driving force in accordance with driver's intention and the vehicle condition, TCM monitors the driving conditions, such as the vehicle speed and the throttle position and selects the optimum gear ratio, and determines the gear change steps to the gear ratio. Then TCM sends the command to the step motor, controls the inflow/outflow of line pressure from the primary pulley to determine the position of the moving-pulley and controls the gear ratio.

“D” POSITION  
 Shifting over all the ranges of gear ratios from the lowest to the highest.

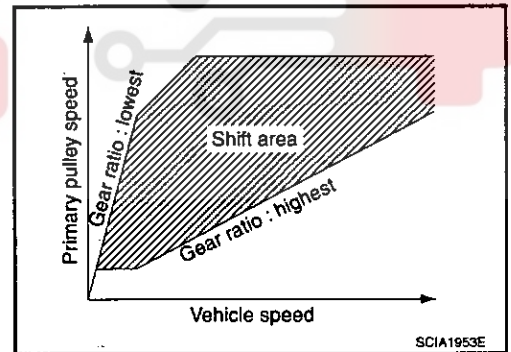

“M” POSITION

When the selector lever is put in the manual shift gate side, the fixed changing gear line is set. By moving the selector lever to + side or - side, the manual mode switch is changed over, and shift change like M/T becomes possible following the changing gear set line step by step.

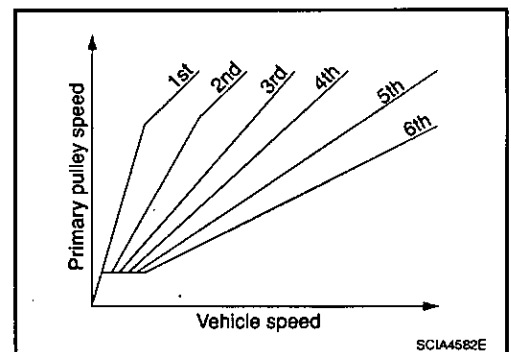

DOWNHILL ENGINE BRAKE CONTROL (AUTO ENGINE BRAKE CONTROL)

When a downhill slope is detected with the accelerator pedal released, the engine brake will be strengthened up by downshifting so as not to accelerate the vehicle more than necessary.

ACCELERATION CONTROL

SHIFT CONTROL SYSTEM

< FUNCTION DIAGNOSIS >

[CVT: RE0F10A]

According to vehicle speed and a change of accelerator pedal angle, driver's request for acceleration and driving scene are judged. This function assists improvement in the acceleration feeling by making the engine speed proportionate to the vehicle speed. And a shift map that can gain a larger driving force is available for compatibility of mileage with driveability.

Component Parts Location

INFOID:000000004905161

CAUTION:

This is applied to TCM parts number "31036 JD00A, 31036 JD02A, 31036 JD10A and 31036 JD12A".

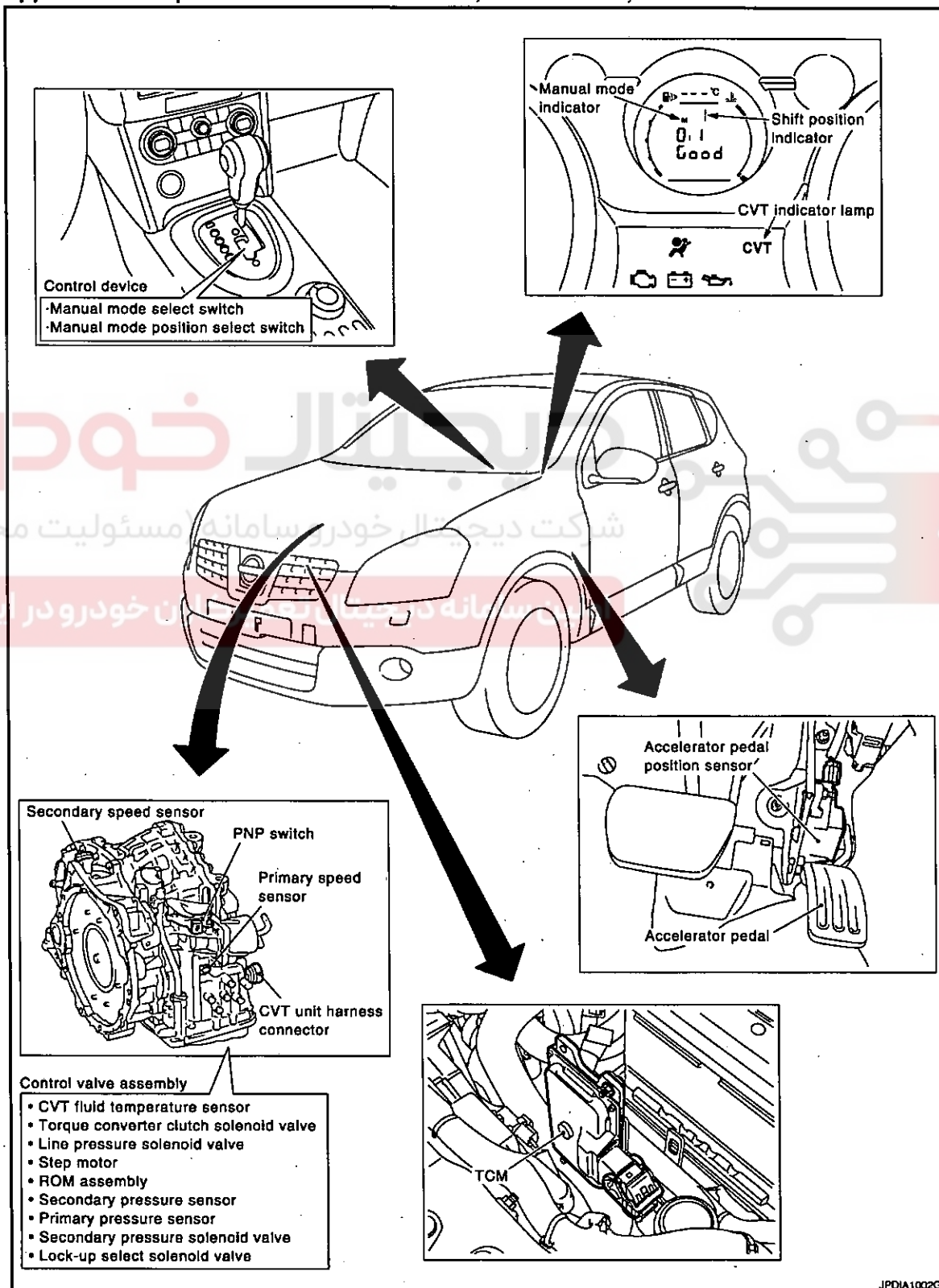

شکت دیجیتال خودرو  
 شرکت دیجیتال خودرو سامانه مسئولیت محدود  
 سامانه دیجیتال خودرو در ایران

CAUTION:

SHIFT CONTROL SYSTEM

< FUNCTION DIAGNOSIS >

[CVT: RE0F10A]

This is applied to TCM parts except number "31036 JD00A, 31036 JD02A, 31036 JD10A and 31036 JD12A".

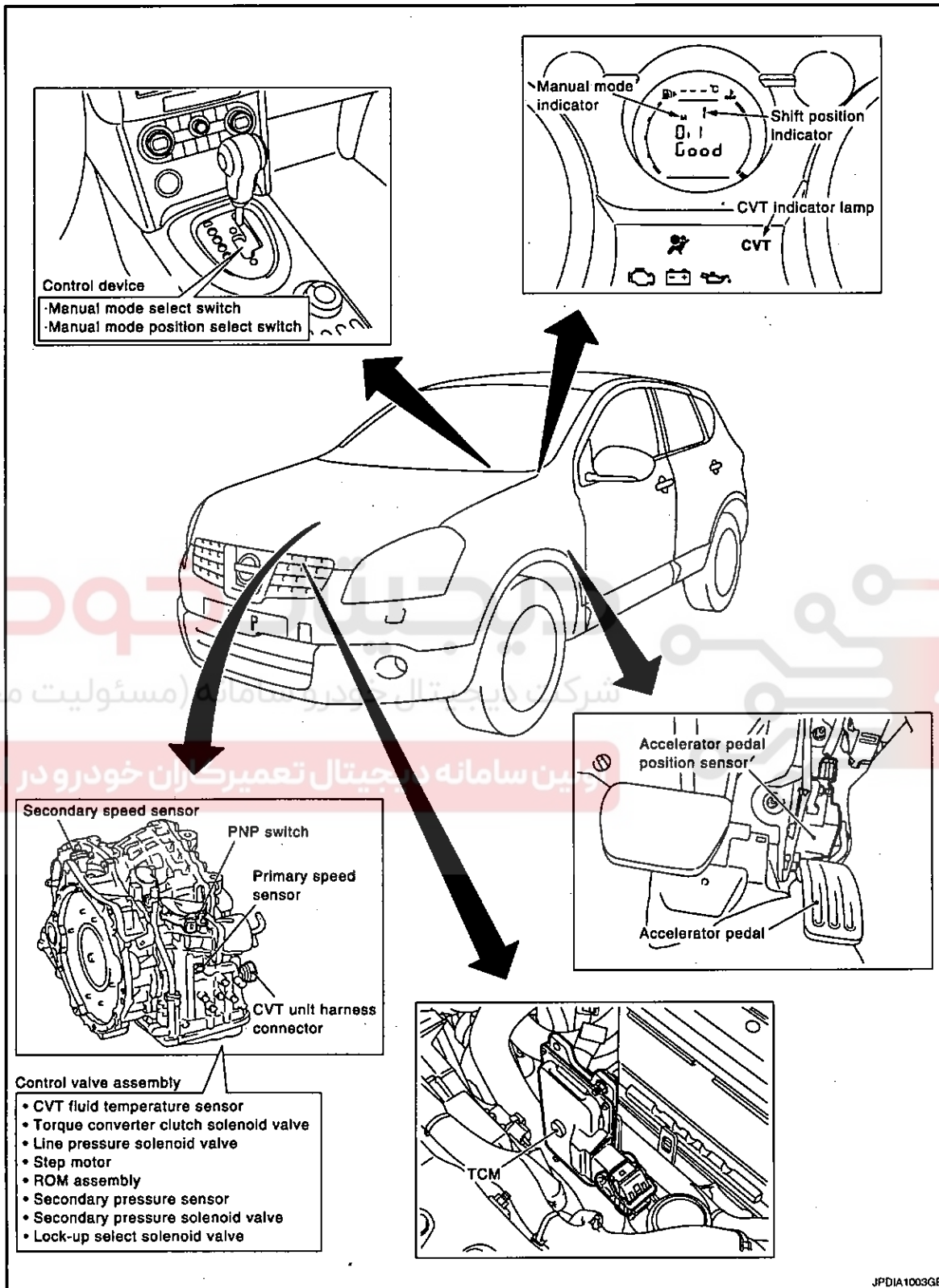

JPDIA1003GB

Component Description

INFOID:000000004905162

TRANSAXLE ASSEMBLY

A  
B  
C  
TM  
E  
F  
G  
H  
I  
J  
K  
L  
M  
N  
O  
P

## SHIFT CONTROL SYSTEM

&lt; FUNCTION DIAGNOSIS &gt;

[CVT: RE0F10A]

Item	Function
PNP switch	
Primary speed sensor	
Secondary speed sensor	TM-18
Step motor	
Shift control valve	
Primary pulley	
Secondary pulley	TM-12

## EXCEPT TRANSAXLE ASSEMBLY

Item	Function
TCM	TM-23

# دیجیتال خودرو

شرکت دیجیتال خودرو سامانه (مسئولیت محدود)

اولین سامانه دیجیتال تعمیرکاران خودرو در ایران





< FUNCTION DIAGNOSIS >

SHIFT LOCK SYSTEM

System Description

INFOID:000000004905163

The shift lever it cannot be shifted from the "P" position unless the brake pedal is depressed while the ignition switch is set to ON. The shift lock is unlocked by turning the shift lock solenoid ON when the ignition switch is set to ON, the park position switch is turned ON (selector lever is in "P" position), and the stop lamp switch is turned ON (brake pedal is depressed) as shown in the operation chart in the figure. Therefore, the shift lock solenoid receives no ON signal and the shift lock remains locked if all of the above conditions are not fulfilled. (However, selector operation is allowed if the shift lock release button is pressed.)

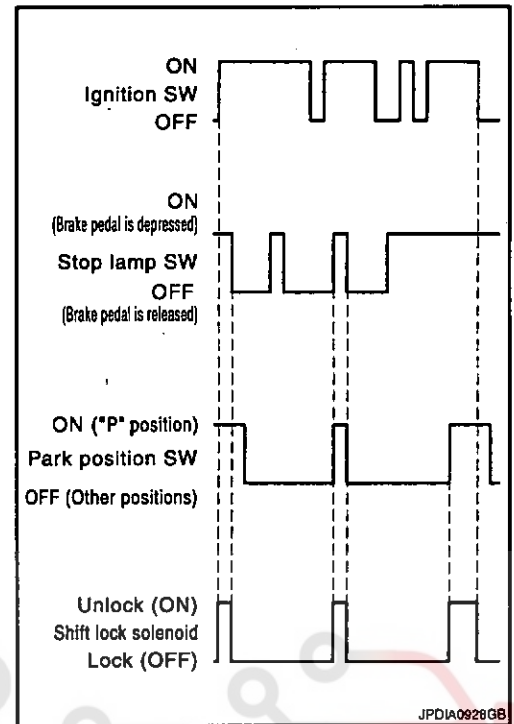

(SHIFT LOCK OPERATION AT "P" POSITION)

When Brake Pedal Is Not Depressed (No Selector Operation Allowed)

The shift lock solenoid (1) is turned OFF (not energized) and the solenoid rod (A) is extended with the spring when the brake pedal is not depressed (no selector operation allowed) with the ignition switch ON.

The connecting lock lever (B) is located at the position shown in the figure when the solenoid rod is extended. It prevents the movement of the detent rod (C). For these reasons, the selector lever cannot be shifted from the "P" position.

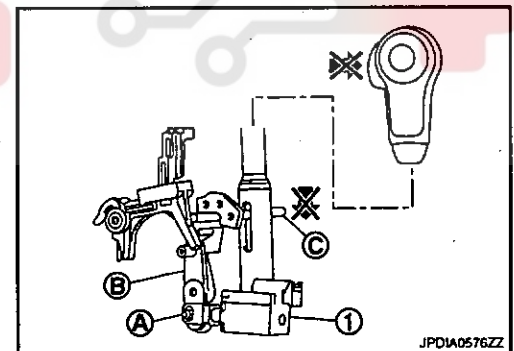

When Brake Pedal Is Depressed (Shift Operation Allowed)

The shift lock solenoid (1) is turned ON (energized) when the brake pedal is depressed with the ignition switch ON. The solenoid rod (A) is compressed by the electromagnetic force. The connecting lock lever (B) rotates when the solenoid rod is activated. Therefore, the detent rod (C) can be moved. For these reasons, the selector lever can be shifted to other positions.

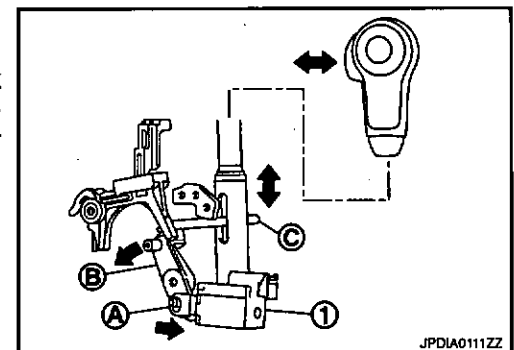

"P" POSITION HOLD MECHANISM (IGNITION SWITCH LOCK)

SHIFT LOCK SYSTEM

< FUNCTION DIAGNOSIS >

[CVT: RE0F10A]

The shift lock solenoid (1) is not energized when the ignition switch is in any position other than ON. In this condition, the shift mechanism is locked and "P" position is held. The operation cannot be performed from "P" position if the brake pedal is depressed with the ignition switch ON when the operation system of shift lock solenoid is malfunctioning. However, the lock lever (A) is forcibly rotated and the shift lock is released when the shift lock release button (B) is pressed from above. Then the selector operation from "P" position can be performed.

**CAUTION:**

**Use the shift lock release button only when the selector lever cannot be operated even if the brake pedal is depressed with the ignition switch ON.**

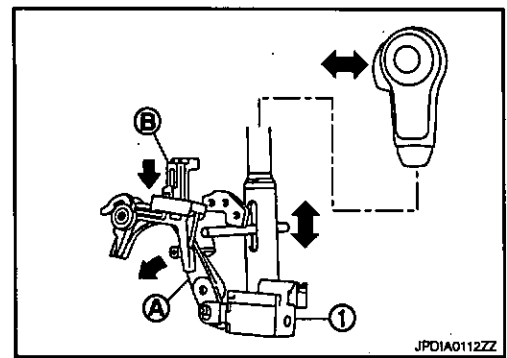

KEY LOCK MECHANISM

The key cannot be set to LOCK when the selector lever is not selected to "P" position. This prevents the key from being removed from the key cylinder.

Key Lock Status

The slider (A) in the key cylinder (B) is moved to the left side of the figure when the selector lever is in any position other than "P" position. The rotator (C) that rotates together with the key (D) cannot be rotated for this reason. The key cannot be removed from the key cylinder because it cannot be turned to LOCK (E).

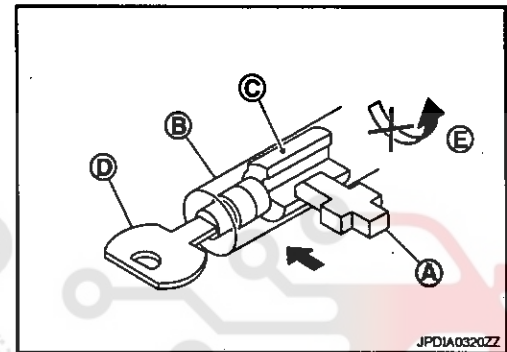

Key Unlock Status

The slider (A) in the key cylinder (B) is moved to the right side of the figure when the selector lever is in "P" position and the finger is removed from the selector button. The rotator (C) can be rotated for this reason. The key (D) can be removed from the key cylinder because it can be turned to LOCK (E).

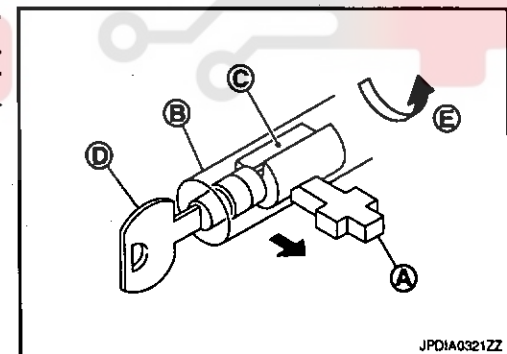

دیجیتال خودرو  
شرکت دیجیتال خودرو سامانه (مسئولیت محدود)

SHIFT LOCK SYSTEM

< FUNCTION DIAGNOSIS >

[CVT: RE0F10A]

Component Parts Location

INFOID:000000004905164

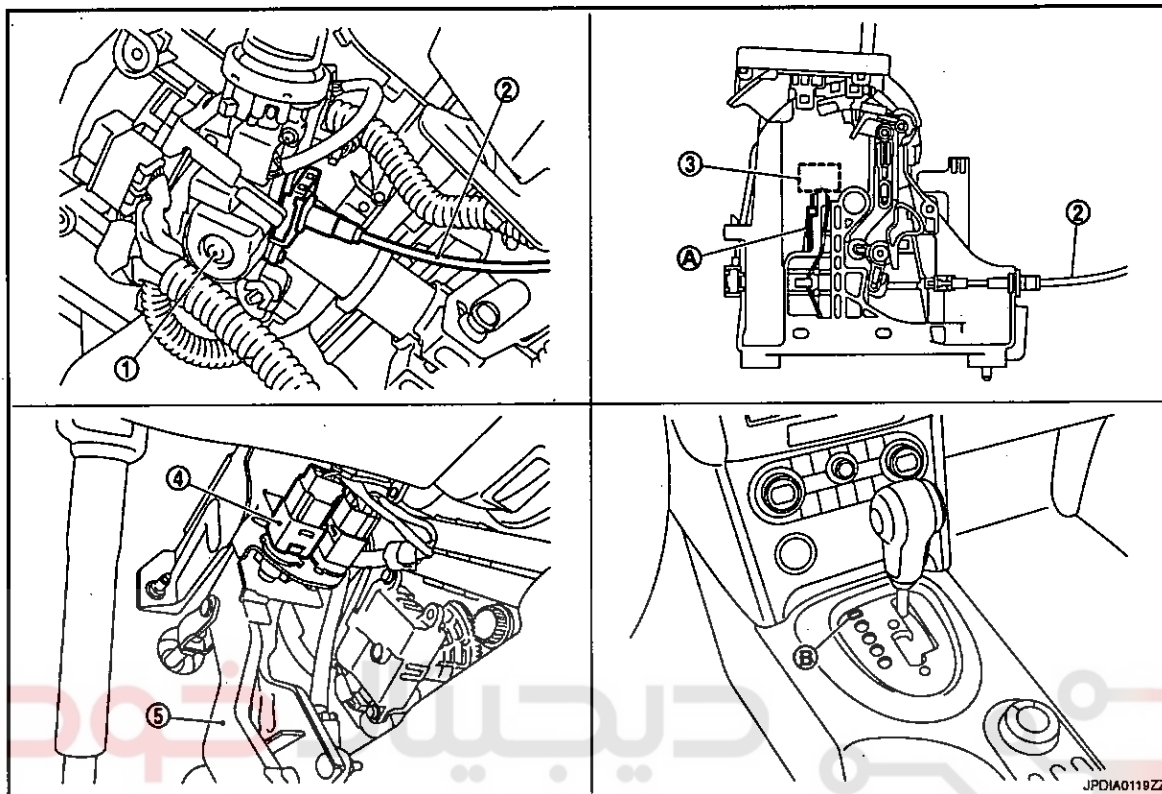

A  
B  
C  
TM  
E  
F  
G  
H  
I  
J

- 1. Key cylinder
- 2. Key interlock cable
- 3. Shift lock solenoid
- 4. Stop lamp switch
- 5. Brake pedal
- A. Park position switch
- B. Shift lock release button\*

\*: Shift lock release button becomes operative by removing shift lock cover. (LHD only)

Component Description

INFOID:000000004905165

SHIFT LOCK

Component	Function
Shift lock solenoid	TM-38
Lock lever	
Detent rod	
Park position switch	
Key interlock cable and rod	
Shift lock release button	

KEY LOCK

Component	Function
Key cylinder	Rotator It rotates together with the key and restricts the slider movement when the ignition switch is in LOCK position.
	Slider It moves according to the rotation of the lock lever.
Key interlock cable and key interlock rod	Actuation of lock lever is conveyed to slider in the key cylinder.

K  
L  
M  
N  
O  
P

## ON BOARD DIAGNOSTIC (OBD) SYSTEM

## Diagnosis Description

INFOID:000000004905166

## DESCRIPTION

The CVT system has two self-diagnostic systems.

The first is the emission-related on board diagnostic system (OBD) performed by the TCM in combination with the ECM. A malfunction is indicated by the MIL (Malfunction Indicator Lamp) and is stored as a DTC in the ECM memory and in the TCM memory.

The second is the TCM original self-diagnosis performed by the TCM. A malfunction history is stored in the TCM memory. The detected items are overlapped with OBD self-diagnostic items.

## OBD FUNCTION

The ECM provides emission-related on board diagnostic (OBD) functions for the CVT system. One function is to receive a signal from the TCM used with OBD-related parts of the CVT system. The signal is sent to the ECM when a malfunction occurs in the corresponding OBD-related part. The other function is to indicate a diagnostic result by means of the MIL (Malfunction Indicator Lamp) on the instrument panel. Sensors, switches and solenoid valves are used as sensing elements.

The MIL automatically illuminates in "One or Two Trip Detection Logic" when a malfunction is sensed in relation to CVT system parts.

## MALFUNCTION INDICATOR Lamp (MIL)

## Description

The MIL is located on the instrument panel.

1. The MIL is turned ON when the ignition switch is turned ON without the engine running. This is a bulb check.
  - If the MIL is not turned ON, refer to EC-254, "Component Function Check" [WITH OBD (MR TYPE1)].
2. Turn OFF the MIL when the engine is started. If the MIL remains ON, the on board diagnostic system has detected an engine system malfunction.

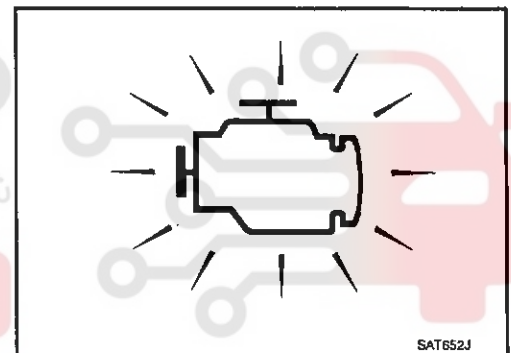

اولین سامانه دیجیتال تعمیرکاران خودرو در ایران

## SHIFT POSITION INDICATOR CIRCUIT

&lt; COMPONENT DIAGNOSIS &gt;

[CVT: RE0F10A]

## COMPONENT DIAGNOSIS

## SHIFT POSITION INDICATOR CIRCUIT

## Description

INFOID:000000004905265

- TCM sends position indicator signals to combination meter via CAN communication line.
- Manual mode switch position is indicated on shift position indicator.

A

B

C

TM

E

F

G

H

I

J

K

L

M

N

O

P

دیجیتال خودرو

شرکت دیجیتال خودرو سامانه (مسئولیت محدود)

اولین سامانه دیجیتال تعمیرکاران خودرو در ایران



## SHIFT LOCK SYSTEM

&lt; COMPONENT DIAGNOSIS &gt;

[CVT: RE0F10A]

## SHIFT LOCK SYSTEM

## Description

INFOID:000000004905268

Component	Function
Shift lock solenoid	It operates according to the signal from the stop lamp switch and moves the lock lever.
Lock lever	It moves according to the operation of the shift lock solenoid and performs the release of the shift lock.
Detent rod	It links with the selector button and restricts the selector lever movement.
Park position switch	It detects that the selector lever is in "P" position.
Key interlock cable and key interlock rod	It transmits the lock lever operation to the slider in the key cylinder.
Shift lock release button	It moves the lock lever forcibly.

## Wiring Diagram - CVT SHIFT LOCK SYSTEM -

INFOID:000000004905269

# دیجیتال خودرو

شرکت دیجیتال خودرو سامانه (مسئولیت محدود)

اولین سامانه دیجیتال تعمیرکاران خودرو در ایران



CVT SHIFT LOCK SYSTEM

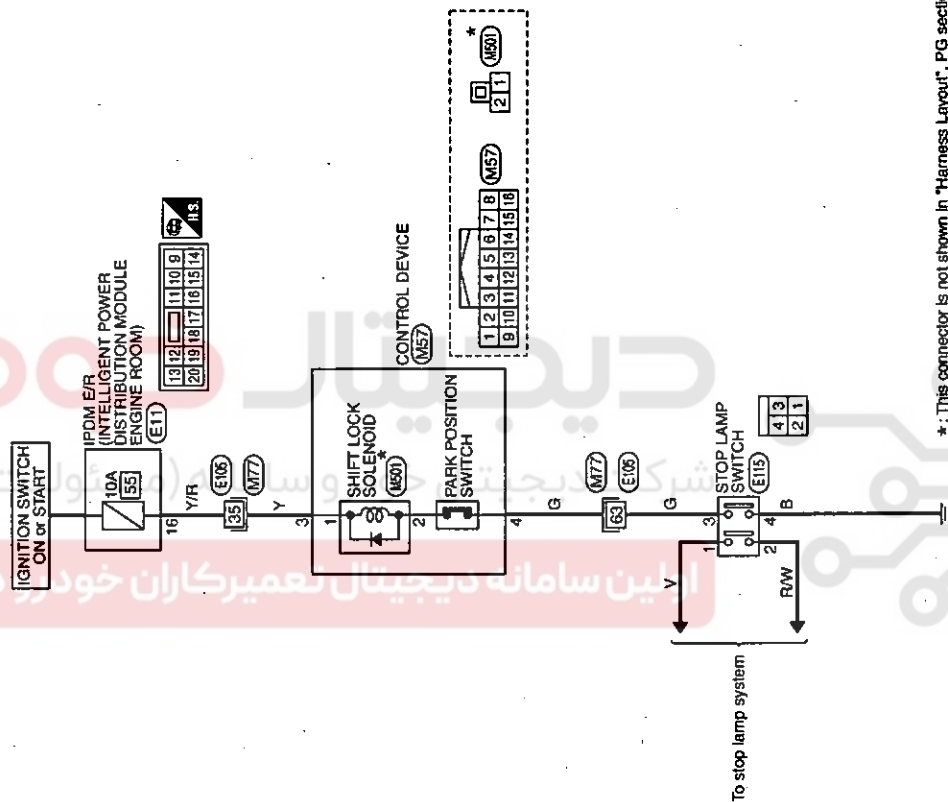

Refer to the following (M77)-SUPER MULTIPLE JUNCTION (SMJ)

\*: This connector is not shown in "Harness Layout", PG section.

A  
B  
C  
TM  
E  
F  
G  
H  
I  
J  
K  
L  
M  
N  
O  
P

Component Function Check

1. CHECK CVT SHIFT LOCK OPERATION

1. Turn ignition switch ON.
2. Shift the selector lever to the "P" position.
3. Attempt to shift the selector lever to any other position with the brake pedal released.

Can the selector lever be shifted to any other position?

JMDWA0005G1

INFOID:000000004905270

SHIFT LOCK SYSTEM

< COMPONENT DIAGNOSIS >

[CVT: RE0F10A]

- YES >> Go to TM-40, "Diagnosis Procedure".  
 NO >> GO TO 2.

**2. CHECK CVT SHIFT LOCK OPERATION**

Attempt to shift the selector lever to any other position with the brake pedal depressed.

Can the selector lever be shifted to any other position?

- YES >> INSPECTION END  
 NO >> Go to TM-40, "Diagnosis Procedure".

**Diagnosis Procedure**

INFOID:000000004905271

**1. CHECK POWER SOURCE**

1. Turn ignition switch ON.
2. Check voltage between control device harness connector and ground.

Control device harness connector		Ground	Voltage (Approx.)
Connector	Terminal		
M57	3		Battery Voltage

Is the inspection result normal?

- YES >> GO TO 2.  
 NO >> • Harness for short or open between ignition switch and control device harness connector terminal 3  
 • 10A fuse (No. 55, located in the IPDM E/R)  
 • Ignition switch

**2. CHECK HARNESS BETWEEN CONTROL DEVICE AND STOP LAMP SWITCH**

1. Turn ignition switch OFF.
2. Disconnect control device harness connector and stop lamp switch connector.
3. Check continuity between control device harness connector terminal and stop lamp switch connector terminal.

Control device harness connector		Stop lamp switch harness connector		Continuity
Connector	Terminal	Connector	Terminal	
M57	4	E115	3	Existed

4. If OK, check harness for short to ground and short to power.

Is the inspection result normal?

- YES >> GO TO 3.  
 NO >> Repair open circuit or short to ground or short to power in harness or connectors.

**3. CHECK STOP LAMP SWITCH**

Check stop lamp switch. Refer to TM-41, "Component Inspection (Stop Lamp Switch)".

Is the inspection result normal?

- YES >> GO TO 4.  
 NO >> Repair or replace damaged parts.

**4. CHECK GROUND CIRCUIT**

Check continuity between stop lamp switch harness connector and ground.

Stop lamp switch harness connector		Ground	Continuity
Connector	Terminal		
E115	4		Existed

Is the inspection result normal?

- YES >> GO TO 5.  
 NO >> Repair open circuit or short to ground or short to power in harness or connectors.



SHIFT LOCK SYSTEM

< COMPONENT DIAGNOSIS >

[CVT: RE0F10A]

5. CHECK CONTROL DEVICE

1. Move selector lever to "P" position.
2. Check continuity between control device harness connector terminals.

Control device harness connector			Continuity
Connector	Terminal		
M57	3	4	Existed

Is the inspection result normal?

- YES >> GO TO 6.  
 NO >> Replace control device. Refer to TM-76, "Exploded View".

6. CHECK SHIFT LOCK SOLENOID

Check shift lock solenoid. Refer to TM-41, "Component Inspection (Shift Lock Solenoid)".

Is the inspection result normal?

- YES >> INSPECTION END  
 NO >> Replace control device. Refer to TM-76, "Exploded View".

Component Inspection (Stop Lamp Switch)

INFOID:000000004905272

1. CHECK STOP LAMP SWITCH

1. Disconnect stop lamp switch harness connector.
2. Check continuity between stop lamp switch connector terminal 3 and 4.

Stop lamp switch connector			Condition	Continuity
Connector	Terminal			
E115	3	4	Depressed brake pedal	Existed
			Released brake pedal	Not existed

Is the inspection result normal?

- YES >> INSPECTION END  
 NO >> Replace stop lamp switch. Refer to BR-17, "Exploded View" (LHD), BR-61, "Exploded View" (RHD).

Component Inspection (Shift Lock Solenoid)

INFOID:000000004905273

1. CHECK SHIFT LOCK SOLENOID

1. Remove shift lock solenoid. Refer to TM-76, "Exploded View".
2. Apply voltage to terminals 1 and 2 of shift lock solenoid harness connector and then check that shift lock solenoid is activated.

**CAUTION:**

**Connect the fuse between the terminals when applying the voltage.**

(+)(fuse)		(-)		Condition	Status
shift lock solenoid harness connector					
Connector	Terminal				
M501	1	2		Apply 12 V direct current between terminals 1 and 2.	Shift lock solenoid operates

Can the lock plate be moved up and down?

- YES >> INSPECTION END  
 NO >> Replace shift lock solenoid. Refer to TM-76, "Exploded View".

# ECU DIAGNOSIS

## TCM

Reference Value

INFOID:000000004905274

### TERMINAL LAYOUT

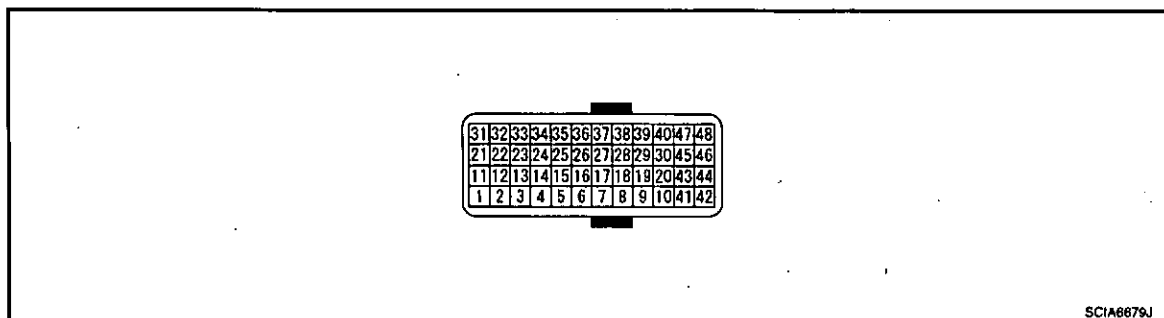

### PHYSICAL VALUES

Terminal No. (wire color)		Description		Condition		Value (Approx.)
+	-	Signal name	Input/Output			
1 (Y/G)	Ground	R RANGE SW	Input	Selector lever in "R" position	Battery voltage	
				Other than the above position	0 V	
2 (P/B)	Ground	N RANGE SW	Input	Selector lever in "N" position	Battery voltage	
				Other than the above position	0 V	
3 (G/O)	Ground	D RANGE SW	Input	Ignition switch ON Selector lever in "D" positions	Battery voltage	
				Other than the above position	0 V	
4 (GR)	Ground	L RANGE SW	Input	Selector lever in "L" position	Battery voltage	
				Other than the above position	0 V	
5 (B)	Ground	Ground	Output	Always	0 V	
6 (O)	Ground	K-LINE	Input/Output	—	—	
7 (R/W)	Ground	Sensor ground	Input	Always	0 V	
8 (G/W)	—	CLOCK (SEL2)	—	—	—	
9 (L/R)	—	CHIP SELECT (SEL1)	—	—	—	
10 (Y)	—	DATA I/O (SEL3)	—	—	—	
11 (BR/W)	Ground	P RANGE SW	Input	Ignition switch ON Selector lever in "P" position	Battery voltage	
				Other than the above position	0 V	
13 (V)	Ground	CVT fluid temperature sensor	Input	Ignition switch ON When CVT fluid temperature is 20°C (68°F)	2.0 V	
				When CVT fluid temperature is 80°C (176°F)	1.0 V	

TCM

< ECU DIAGNOSIS >

[CVT: RE0F10A]

Terminal No. (wire color)		Description		Condition		Value (Approx.)	
+	-	Signal name	Input/Output				
14 (LG)	Ground	Transmission fluid pressure sensor B (Primary pressure sensor)*	Input	"N" position idle		0.7 – 3.5 V	A
15 (V/W)	Ground	Transmission fluid pressure sensor A (Secondary pressure sensor)	Input			1.0 V	B
25 (W/R)	Ground	Sensor ground	Input	Always		0 V	C
26 (L/O)	Ground	Sensor power	Output	Ignition switch ON	—	5.0 V	TM
				Ignition switch OFF	—	0 V	
27 (R/G)	Ground	Step motor D	Output	Within 2 seconds after ignition switch ON		10.0 msec	E
28 (R)	Ground	Step motor C	Output			30.0 msec	F
29 (O/B)	Ground	Step motor B	Output			10.0 msec	G
30 (G/R)	Ground	Step motor A	Output			30.0 msec	
31 (P)	—	CAN-L	Input/Output	—		—	H
32 (L)	—	CAN-H	Input/Output	—		—	
33 (LG/R)	Ground	Input speed sensor (Primary speed sensor)	Input	When driving ["M1" position, 20 km/h (12 MPH)]		800 Hz	I
34 (W)	Ground	Output speed sensor (Secondary speed sensor)	Input	When driving ["D" position, 20 km/h (12 MPH)]		500 Hz	J
37 (L/W)	Ground	Lock-up select solenoid valve	Output	Ignition switch ON	Selector lever in "P" or "N" positions	Battery voltage	K
					Wait at least for 5 seconds with the selector lever in "R" or "D" positions.	0 V	
38 (G)	Ground	Torque converter clutch solenoid valve	Output	When vehicle cruises in "D" position	When CVT performs lock-up	6.0 V	L
					When CVT does not perform lock-up	1.5 V	
39 (W/G)	Ground	Pressure control solenoid valve B (Secondary pressure solenoid valve)	Output	"P" or "N" position idle	Release your foot from the accelerator pedal.	5.0 – 7.0 V	M
					Press the accelerator pedal all the way down.	3.0 – 4.0 V	N
					Release your foot from the accelerator pedal.	5.0 – 7.0 V	
40 (R/Y)	Ground	Pressure control solenoid valve A (Line pressure solenoid valve)	Output		Press the accelerator pedal all the way down.	1.0 V	O
42 (B)	Ground	Ground	Output	Always		0 V	P
45 (R/B)	Ground	Power supply (memory back-up)	Input	Always		Battery voltage	
46 (Y/R)	Ground	Power supply	Input	Ignition switch ON	—	Battery voltage	
				Ignition switch OFF	—	0 V	
47 (R/B)	Ground	Power supply (memory back-up)	Input	Always		Battery voltage	

## TCM

&lt; ECU DIAGNOSIS &gt;

[CVT: RE0F10A]

Terminal No. (wire color)		Description		Condition		Value (Approx.)
+	-	Signal name	Input/Output			
48 (Y/R)	Ground	Power supply	Input	Ignition switch ON	--	Battery voltage
				Ignition switch OFF	--	0 V

\*: This is applied to TCM parts number "31036 JD00A, 31036 JD02A, 31036 JD10A and 31036 JD12A".

# دیجیتال خودرو

شرکت دیجیتال خودرو سامانه (مسئولیت محدود)

اولین سامانه دیجیتال تعمیرکاران خودرو در ایران



Wiring Diagram - CVT CONTROL SYSTEM -

INFOID:000000004905275

CVT CONTROL SYSTEM

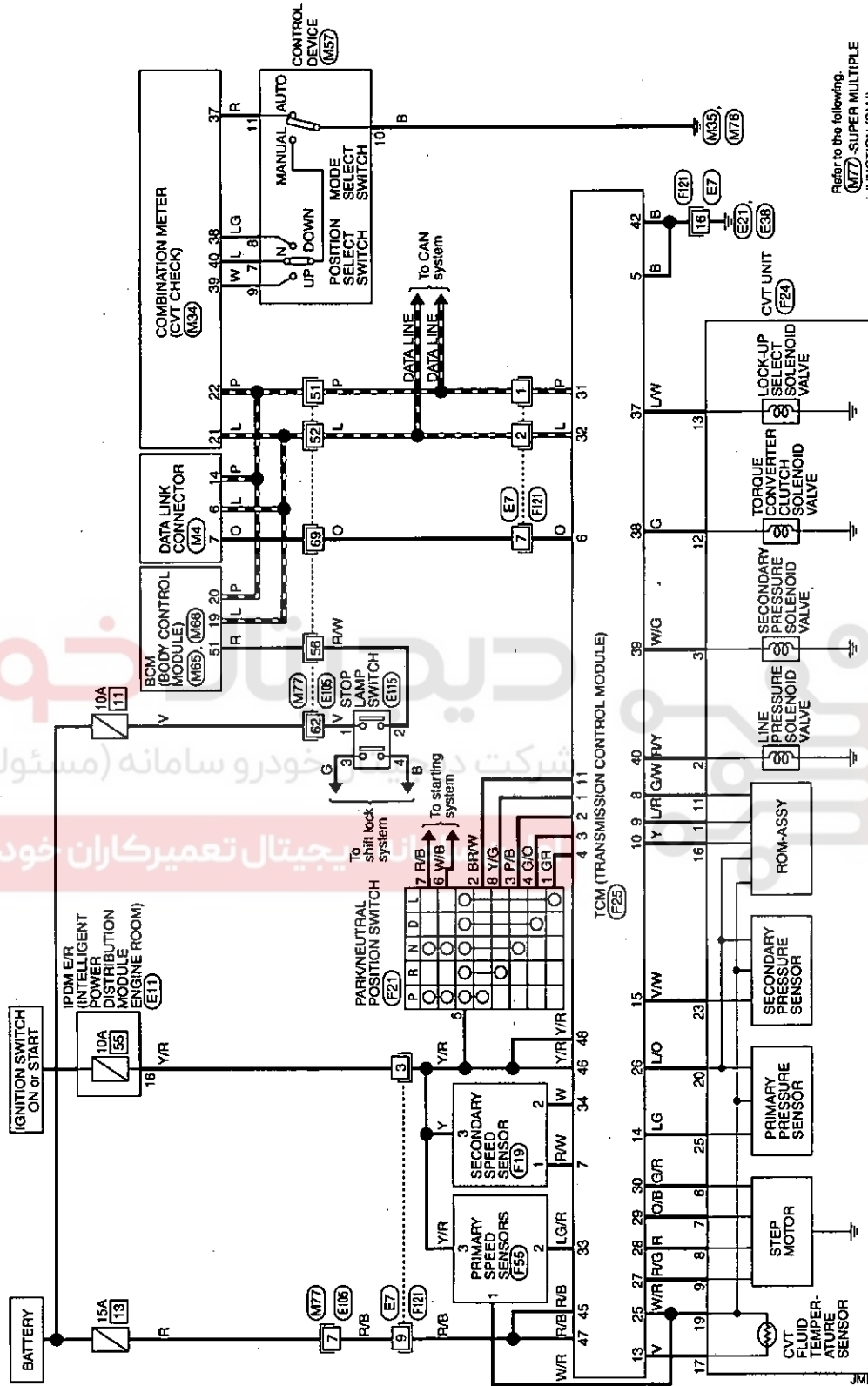

Refer to the following:  
(M77) - SUPER MULTIPLE JUNCTION (SMJ)

A  
B  
C  
TM  
F  
T  
G  
I  
L  
K  
L  
M  
N  
O  
P

خودرو دیجیتال  
 شرکت دیجیتال خودروسازانه (مسئولیت محدود)  
 اولین سامانه دیجیتال تعمیرکاران خودرو در ایران

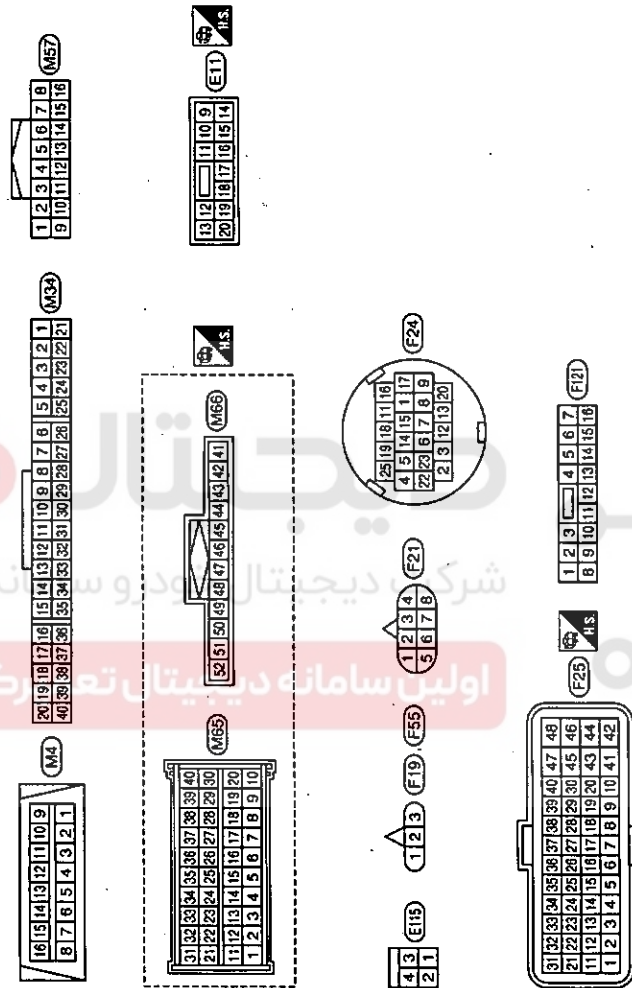

JMDWA0007GI

INFOID:000000004905276

### Fail-safe

The TCM has an electrical fail-safe mode. In this mode TCM is operates even if there is an error in a main electronic control input/output signal circuit.

### FAIL-SAFE FUNCTION

If any malfunction occurs in a sensor or solenoid, this function controls the CVT to make driving possible.

Output Speed Sensor (Secondary Speed Sensor)

TCM

[CVT: RE0F10A]

< ECU DIAGNOSIS >

The shift pattern is changed in accordance with throttle position when an unexpected signal is sent from the output speed sensor (secondary speed sensor) to the TCM. The manual mode is inhibited, and the transaxle is put in "D". A

Input Speed Sensor (Primary Speed Sensor)

The shift pattern is changed in accordance with throttle position and secondary speed (vehicle speed) when an unexpected signal is sent from the input speed sensor (primary speed sensor) to the TCM. The manual mode is inhibited, and the transaxle is put in "D". B

PNP Switch C

If an unexpected signal is sent from the PNP switch to the TCM, the transaxle is put in "D".

Manual Mode Switch

If an unexpected signal is sent from the manual mode switch to the TCM, the transaxle is put in "D". TM

CVT Fluid Temperature Sensor

If an unexpected signal is sent from the CVT fluid temperature sensor to the TCM, the gear ratio in use before receiving the unexpected signal is maintained or the gear ratio is controlled to keep engine speed under 5,000 rpm. E

Transmission Fluid Pressure Sensor A (Secondary Pressure Sensor)

- If an unexpected signal is sent from the transmission fluid pressure sensor A (secondary pressure sensor) to the TCM, the secondary pressure feedback control is stopped and the offset value obtained before the non-standard condition occurs is used to control line pressure. F

- If transmission fluid pressure sensor A (secondary pressure sensor) error signal is input to TCM, secondary pressure feedback control stops, but line pressure is controlled normally. G

Pressure Control Solenoid A (Line Pressure Solenoid valve)

If an unexpected signal is sent from the solenoid to the TCM, the pressure control solenoid A (line pressure solenoid valve) is turned OFF to achieve the maximum fluid pressure. H

Pressure Control Solenoid B (Secondary Pressure Solenoid valve)

If an unexpected signal is sent from the solenoid to the TCM, the pressure control solenoid B (secondary pressure solenoid valve) is turned OFF to achieve the maximum fluid pressure. I

Torque Converter Clutch Solenoid valve

If an unexpected signal is sent from the solenoid to the TCM, the torque converter clutch solenoid valve is turned OFF to cancel the lock-up. J

Step Motor

If an unexpected signal is sent from the step motor to the TCM, the step motor coil phases "A" through "D" are all turned OFF to hold the gear ratio used just before the non-standard condition occurred. K

CVT Lock-up Select Solenoid valve

If an unexpected signal is sent from the solenoid to the TCM, the CVT lock-up select solenoid valve is turned OFF to cancel the lock-up. L

TCM Power Supply (Memory Back-up)

Transaxle assembly is protected by limiting the engine torque when the memory back-up power supply (for controlling) from the battery is not supplied to TCM. Normal status is restored when turning the ignition switch OFF to ON after the normal power supply. M

N

O

P

## SYSTEM SYMPTOM

&lt; SYMPTOM DIAGNOSIS &gt;

[CVT: RE0F10A]

## SYMPTOM DIAGNOSIS

## SYSTEM SYMPTOM

## Symptom Table

INFOID:000000004905279

The diagnostics item numbers show the sequence for inspection. Inspect in order from item 1.

No.	Item	Symptom	Condition	Diagnostic Item
1		Large shock. ("N"→"D" position)	ON vehicle	1. Engine idle speed
				2. Engine speed signal
				3. Accelerator pedal position sensor
				4. CVT position
				5. CVT fluid temperature sensor
				6. CAN communication line
				7. CVT fluid level and state
				8. Line pressure test
				9. Torque converter clutch solenoid valve
				10. Lock-up select solenoid valve
				11. PNP switch
			OFF vehicle	12. Forward clutch
				13. Control valve
2	Shift Shock	Large shock. ("N"→"R" position)	ON vehicle	1. Engine idle speed
				2. Engine speed signal
				3. Accelerator pedal position sensor
				4. CVT position
				5. CVT fluid temperature sensor
				6. CAN communication line
				7. CVT fluid level and state
				8. Line pressure test
				9. Torque converter clutch solenoid valve
				10. Lock-up select solenoid valve
				11. PNP switch
			OFF vehicle	12. Reverse brake
				13. Control valve
3		Shock is too large for lock-up.	ON vehicle	1. CVT position
				2. Engine speed signal
				3. CAN communication line
				4. CVT fluid level and state
			OFF vehicle	5. Torque converter
				6. Control valve



SYSTEM SYMPTOM

< SYMPTOM DIAGNOSIS >

[CVT: RE0F10A]

No.	Item	Symptom	Condition	Diagnostic Item	
4	Slips/Will Not Engage	Vehicle cannot be started from "D" position.	ON vehicle	1. CVT fluid level and state	A
				2. CVT position	B
				3. CAN communication line	B
				4. Line pressure test	
				5. Stall test	C
				6. Step motor	C
				7. Primary speed sensor	
				8. Secondary speed sensor	TM
				9. Accelerator pedal position sensor	
				10. CVT fluid temperature sensor	
				11. Secondary pressure sensor	E
				12. Power supply	
			OFF vehicle	13. Oil pump assembly	F
				14. Forward clutch	
				15. Control valve	
				16. Parking components	G
5	Slips/Will Not Engage	Vehicle cannot be started from "R" position.	ON vehicle	1. CVT fluid level and state	H
				2. CVT position	H
				3. CAN communication line	
				4. Line pressure test	
				5. Stall test	I
				6. Step motor	
				7. Primary speed sensor	
				8. Secondary speed sensor	J
				9. Accelerator pedal position sensor	
				10. CVT fluid temperature sensor	K
				11. Secondary pressure sensor	
				12. Power supply	
			OFF vehicle	13. Oil pump assembly	L
				14. Reverse brake	
				15. Control valve	M
				16. Parking components	

## SYSTEM SYMPTOM

&lt; SYMPTOM DIAGNOSIS &gt;

[CVT: RE0F10A]

No.	Item	Symptom	Condition	Diagnostic Item
6	Slips/Will Not Engage	Does not lock-up.	ON vehicle	1. CVT fluid level and state
				2. Line pressure test
				3. Engine speed signal
				4. Primary speed sensor
				5. Torque converter clutch solenoid valve
				6. CAN communication line
				7. Stall test
				8. Step motor
				9. PNP switch
				10. Lock-up select solenoid valve
				11. CVT fluid temperature sensor
				12. Secondary speed sensor
				13. Secondary pressure sensor
			OFF vehicle	14. Torque converter
				15. Oil pump assembly
				16. Control valve
7	Does not hold lock-up condition.		ON vehicle	1. CVT fluid level and state
				2. Line pressure test
				3. Engine speed signal
				4. Primary speed sensor
				5. Torque converter clutch solenoid valve
				6. CAN communication line
				7. Stall test
				8. Step motor
				9. PNP switch
				10. Lock-up select solenoid valve
				11. CVT fluid temperature sensor
				12. Secondary speed sensor
				13. Secondary pressure sensor
			OFF vehicle	14. Torque converter
				15. Oil pump assembly
				16. Control valve

SYSTEM SYMPTOM

< SYMPTOM DIAGNOSIS >

[CVT: RE0F10A]

No.	Item	Symptom	Condition	Diagnostic Item	
8		Lock-up is not released.	ON vehicle	1. CVT fluid level and state	A
				2. Line pressure test	
				3. Engine speed signal	B
				4. Primary speed sensor	
				5. Torque converter clutch solenoid valve	
				6. CAN communication line	C
				7. Stall test	
			OFF vehicle	8. Torque converter	TM
				9. Oil pump assembly	
				10. Control valve	
9	Slips/Will Not Engage	With selector lever in "D" position, acceleration is extremely poor.	ON vehicle	1. CVT fluid level and state	E
				2. Line pressure test	
				3. Stall test	F
				4. Accelerator pedal position sensor	
				5. CAN communication line	G
				6. PNP switch	
				7. CVT position	
				8. Step motor	H
				9. Primary speed sensor	
				10. Secondary speed sensor	
				11. Accelerator pedal position sensor	I
				12. Primary pressure sensor*	
				13. Secondary pressure sensor	
				14. CVT fluid temperature sensor	J
				15. Power supply	
			OFF vehicle	16. Torque converter	K
				17. Oil pump assembly	
				18. Forward clutch	
				19. Control valve	L

## SYSTEM SYMPTOM

&lt; SYMPTOM DIAGNOSIS &gt;

[CVT: RE0F10A]

No.	Item	Symptom	Condition	Diagnostic Item
10	Slips/Will Not Engage	With selector lever in "R" position, acceleration is extremely poor.	ON vehicle	1. CVT fluid level and state
				2. Line pressure test
				3. Stall test
				4. Accelerator pedal position sensor
				5. CAN communication line
				6. PNP switch
				7. CVT position
				8. Step motor
				9. Primary speed sensor
				10. Secondary speed sensor
				11. Accelerator pedal position sensor
				12. Primary pressure sensor*
				13. Secondary pressure sensor
				14. CVT fluid temperature sensor
				15. Power supply
			OFF vehicle	16. Torque converter
				17. Oil pump assembly
				18. Reverse brake
				19. Control valve
11	Slips at lock-up.		ON vehicle	1. CVT fluid level and state
				2. Line pressure test
				3. Engine speed signal
				4. Primary speed sensor
				5. Torque converter clutch solenoid valve
				6. CAN communication line
				7. Stall test
				8. Step motor
				9. PNP switch
				10. Lock-up select solenoid valve
				11. CVT fluid temperature sensor
				12. Secondary speed sensor
				13. Secondary pressure sensor
				OFF vehicle
			15. Oil pump assembly	

SYSTEM SYMPTOM

< SYMPTOM DIAGNOSIS >

[CVT: RE0F10A]

No.	Item	Symptom	Condition	* Diagnostic Item	
12	Others	No creep at all.	ON vehicle	1. CVT fluid level and state	A
				2. Line pressure test	B
				3. Accelerator pedal position sensor	B
				4. PNP switch	
				5. CAN communication line	C
				6. Stall test	
				7. CVT position	
				8. Step motor	TM
				9. Primary speed sensor	
				10. Secondary speed sensor	
				11. Accelerator pedal position sensor	E
				12. CVT fluid temperature sensor	
				13. Primary pressure sensor*	F
				14. Secondary pressure sensor	
				15. Power supply	
13	Others	Vehicle cannot run in all positions.	OFF vehicle	16. Torque converter	G
				17. Oil pump assembly	
				18. Gear system	H
				19. Forward clutch	
				20. Reverse brake	
				21. Control valve	I
				1. CVT fluid level and state	J
				2. Line pressure test	
				3. PNP switch	
			ON vehicle	4. Stall test	
				5. CVT position	K
				6. Step motor	
				7. Primary speed sensor	
				8. Secondary speed sensor	L
				9. Accelerator pedal position sensor	
				10. CVT fluid temperature sensor	
				11. Secondary pressure sensor	M
				12. Power supply	
			OFF vehicle	13. Torque converter	N
14. Oil pump assembly					
15. Gear system	O				
16. Forward clutch					
17. Reverse brake					
18. Control valve	P				
19. Parking components					

## SYSTEM SYMPTOM

&lt; SYMPTOM DIAGNOSIS &gt;

[CVT: RE0F10A]

No.	Item	Symptom	Condition	Diagnostic Item
14	Others	With selector lever in "D" position, driving is not possible.	ON vehicle	1. CVT fluid level and state
				2. Line pressure test
				3. PNP switch
				4. Stall test
				5. CVT position
				6. Step motor
				7. Primary speed sensor
				8. Secondary speed sensor
				9. Accelerator pedal position sensor
				10. CVT fluid temperature sensor
				11. Secondary pressure sensor
				12. Power supply
			OFF vehicle	13. Torque converter
				14. Oil pump assembly
				15. Gear system
				16. Forward clutch
				17. Control valve
				18. Parking components
15	Others	With selector lever in "R" position, driving is not possible.	ON vehicle	1. CVT fluid level and state
				2. Line pressure test
				3. PNP switch
				4. Stall test
				5. CVT position
				6. Step motor
				7. Primary speed sensor
				8. Secondary speed sensor
				9. Accelerator pedal position sensor
				10. CVT fluid temperature sensor
				11. Secondary pressure sensor
				12. Power supply
			OFF vehicle	13. Torque converter
				14. Oil pump assembly
				15. Gear system
				16. Reverse brake
				17. Control valve
				18. Parking components

## SYSTEM SYMPTOM

&lt; SYMPTOM DIAGNOSIS &gt;

[CVT: RE0F10A]

No.	Item	Symptom	Condition	Diagnostic Item	
16		Judder occurs during lock-up.	ON vehicle	1. CVT fluid level and state	A
				2. Engine speed signal	
				3. Primary speed sensor	B
				4. Secondary speed sensor	
				5. Accelerator pedal position sensor	
				6. CAN communication line	C
				7. Torque converter clutch solenoid valve	
			OFF vehicle	8. Torque converter	TM
				9. Control valve	
17	Others	Strange noise in "D" position.	ON vehicle	1. CVT fluid level and state	E
				2. Engine speed signal	
				3. CAN communication line	
			OFF vehicle	4. Torque converter	F
				5. Oil pump assembly	
				6. Gear system	G
				7. Forward clutch	
				8. Control valve	
				9. Bearing	H
18		Strange noise in "R" position.	ON vehicle	1. CVT fluid level and state	
				2. Engine speed signal	
				3. CAN communication line	I
			OFF vehicle	4. Torque converter	
				5. Oil pump assembly	
				6. Gear system	J
				7. Reverse brake	
				8. Control valve	K
19		Strange noise in "N" position.	ON vehicle	1. CVT fluid level and state	
				2. Engine speed signal	
				3. CAN communication line	L
			OFF vehicle	4. Torque converter	
				5. Oil pump assembly	M
				6. Gear system	
				7. Control valve	N

## SYSTEM SYMPTOM

&lt; SYMPTOM DIAGNOSIS &gt;

[CVT: RE0F10A]

No.	Item	Symptom	Condition	Diagnostic Item	
20		Vehicle does not decelerate by engine brake.	ON vehicle	1. CVT fluid level and state	
				2. CVT position	
				3. CAN communication line	
				4. Step motor	
				5. Primary speed sensor	
				6. Secondary speed sensor	
				7. Line pressure test	
				8. Engine speed signal	
				9. Accelerator pedal position sensor	
			OFF vehicle	10. Control valve	
21	Others	Maximum speed low.	ON vehicle	1. CVT fluid level and state	
				2. Line pressure test	
				3. Accelerator pedal position sensor	
				4. CAN communication line	
				5. Stall test	
				6. Step motor	
				7. Primary speed sensor	
				8. Secondary speed sensor	
				9. Primary pressure sensor*	
				10. Secondary pressure sensor	
				11. CVT fluid temperature sensor	
				12. Torque converter	
				13. Oil pump assembly	
				OFF vehicle	14. Gear system
				15. Forward clutch	
			16. Control valve		
22		With selector lever in "P" position, vehicle does not enter parking condition or, with selector lever in another position, parking condition is not cancelled.	ON vehicle	1. PNP switch	
			2. CVT position		
			OFF vehicle	3. Parking components	
23		Vehicle runs with CVT in "P" position.	ON vehicle	1. PNP switch	
				2. CVT fluid level and state	
				3. CVT position	
			OFF vehicle	4. Parking components	
				5. Gear system	
				6. Control valve	



SYSTEM SYMPTOM

< SYMPTOM DIAGNOSIS >

[CVT: RE0F10A]

No.	Item	Symptom	Condition	Diagnostic Item	
24		Vehicle runs with CVT in "N" position.	ON vehicle	1. PNP switch	A
				2. CVT fluid level and state	B
				3. CVT position	
			4. Gear system		
			OFF vehicle	5. Forward clutch	
				6. Reverse brake	
				7. Control valve	
25	Others	Engine stall.	ON vehicle	1. CVT fluid level and state	TM
				2. Engine speed signal	E
				3. Primary speed sensor	
				4. Torque converter clutch solenoid valve	
				5. CAN communication line	F
				6. Stall test	
				7. Secondary pressure sensor	
			OFF vehicle	8. Torque converter	G
				9. Control valve	
26		Engine stalls when selector lever is shifted "N"→"D" or "R".	ON vehicle	1. CVT fluid level and state	H
				2. Engine speed signal	
				3. Primary speed sensor	
				4. Torque converter clutch solenoid valve	
				5. CAN communication line	
				6. Stall test	
			OFF vehicle	7. Torque converter	J
				8. Control valve	
27		Engine speed does not return to idle.	ON vehicle	1. CVT fluid level and state	K
				2. Accelerator pedal position sensor	
				3. Secondary speed sensor	
				4. CAN communication line	
			OFF vehicle	5. Control valve	L

## SYSTEM SYMPTOM

&lt; SYMPTOM DIAGNOSIS &gt;

[CVT: RE0F10A]

No.	Item	Symptom	Condition	Diagnostic Item
28	Others	CVT does not shift	ON vehicle	1. CVT fluid level and state
				2. CVT position
				3. Line pressure test
				4. Engine speed signal
				5. Accelerator pedal position sensor
				6. CAN communication line
				7. Primary speed sensor
				8. Secondary speed sensor
				9. Step motor
			OFF vehicle	10. Control valve
				11. Oil pump assembly
29	Others	Engine does not start in "N" or "P" position.	ON vehicle	1. Ignition switch and starter
				2. CVT position
				3. PNP switch
30	Others	Engine starts in positions other than "N" or "P".	ON vehicle	1. Ignition switch and starter
				2. CVT position
				3. PNP switch
31	Others	When brake pedal is depressed with ignition switch ON, selector lever cannot be shifted from "P" position to other position.	ON vehicle	1. Stop lamp switch
				2. Shift lock solenoid
				3. Control device
32	Others	When brake pedal is not depressed with ignition switch ON, selector lever can be shifted from "P" position to other position.	ON vehicle	1. Stop lamp switch
				2. Shift lock solenoid
				3. Control device
33	Others	Cannot be changed to manual mode.	ON vehicle	1. Manual mode switch
				2. CAN communication line
				3. Combination meters
34	Others	CVT indicator lamp is not turned ON.	ON vehicle	1. CAN communication line
				2. Combination meters
				3. TCM power supply and ground

\*: These items are applied to TCM parts number "31036 JD00A, 31036 JD02A, 31036 JD10A and 31036 JD12A".

## PRECAUTIONS

&lt; PRECAUTION &gt;

[CVT: RE0F10A]

## PRECAUTION

## PRECAUTIONS

## Precaution for Supplemental Restraint System (SRS) "AIR BAG" and "SEAT BELT PRE-TENSIONER"

INFOID:000000005022489

The Supplemental Restraint System such as "AIR BAG" and "SEAT BELT PRE-TENSIONER", used along with a front seat belt, helps to reduce the risk or severity of injury to the driver and front passenger for certain types of collision. This system includes seat belt switch inputs and dual stage front air bag modules. The SRS system uses the seat belt switches to determine the front air bag deployment, and may only deploy one front air bag, depending on the severity of a collision and whether the front occupants are belted or unbelted. Information necessary to service the system safely is included in the "SRS AIR BAG" and "SEAT BELT" of this Service Manual.

**WARNING:**

- To avoid rendering the SRS inoperative, which could increase the risk of personal injury or death in the event of a collision which would result in air bag inflation, all maintenance must be performed by an authorized NISSAN/INFINITI dealer.
- Improper maintenance, including incorrect removal and installation of the SRS, can lead to personal injury caused by unintentional activation of the system. For removal of Spiral Cable and Air Bag Module, see the "SRS AIR BAG".
- Do not use electrical test equipment on any circuit related to the SRS unless instructed to in this Service Manual. SRS wiring harnesses can be identified by yellow and/or orange harnesses or harness connectors.

## PRECAUTIONS WHEN USING POWER TOOLS (AIR OR ELECTRIC) AND HAMMERS

**WARNING:**

- When working near the Air Bag Diagnosis Sensor Unit or other Air Bag System sensors with the ignition ON or engine running, DO NOT use air or electric power tools or strike near the sensor(s) with a hammer. Heavy vibration could activate the sensor(s) and deploy the air bag(s), possibly causing serious injury.
- When using air or electric power tools or hammers, always switch the ignition OFF, disconnect the battery, and wait at least 3 minutes before performing any service.

## Precaution Necessary for Steering Wheel Rotation After Battery Disconnect

INFOID:000000004958931

**NOTE:**

- This Procedure is applied only to models with Intelligent Key system and NATS (NISSAN ANTI-THEFT SYSTEM).
- Remove and install all control units after disconnecting both battery cables with the ignition knob in the "LOCK" position.

For models equipped with the Intelligent Key system and NATS, an electrically controlled steering lock mechanism is adopted on the key cylinder.

For this reason, if the battery is disconnected or if the battery is discharged, the steering wheel will lock and steering wheel rotation will become impossible.

If steering wheel rotation is required when battery power is interrupted, follow the procedure below before starting the repair operation.

## OPERATION PROCEDURE

1. Connect both battery cables.

**NOTE:**

Supply power using jumper cables if battery is discharged.

2. Use the Intelligent Key or mechanical key to turn the ignition switch to the "ACC" position. At this time, the steering lock will be released.
3. Disconnect both battery cables. The steering lock will remain released and the steering wheel can be rotated.
4. Perform the necessary repair operation.
5. When the repair work is completed, return the ignition switch to the "LOCK" position before connecting the battery cables. (At this time, the steering lock mechanism will engage.)

## PRECAUTIONS

&lt; PRECAUTION &gt;

[CVT: RE0F10A]

## Precaution for Procedure without Cowl Top Cover

INFOID:000000004905282

When performing the procedure after removing cowl top cover, cover the lower end of windshield with urethane, etc.

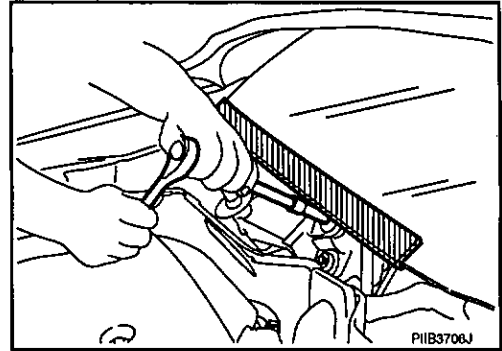

## Precaution for On Board Diagnosis (OBD) System of CVT and Engine

INFOID:000000004905283

The ECM has an on board diagnostic system. It will light up the Malfunction Indicator Lamp (MIL) to warn the driver of a malfunction causing emission deterioration.

**CAUTION:**

- Be sure to turn the ignition switch OFF and disconnect the battery cable from the negative terminal before any repair or inspection work. The open/short circuit of related switches, sensors, solenoid valves, etc. will cause the MIL to light up.
- Be sure to connect and lock the connectors securely after work. A loose (unlocked) connector will cause the MIL to light up due to an open circuit. (Be sure the connector is free from water, grease, dirt, bent terminals, etc.)
- Be sure to route and secure the harnesses properly after work. Interference of the harness with a bracket, etc. may cause the MIL to light up due to a short circuit.
- Be sure to connect rubber tubes properly after work. A misconnected or disconnected rubber tube may cause the MIL to light up due to a malfunction of the EVAP system or fuel injection system, etc.
- Be sure to erase the unnecessary malfunction information (repairs completed) from the TCM and ECM before returning the vehicle to the customer.

## Removal and Installation Procedure for CVT Unit Connector

INFOID:000000004905285

**REMOVAL**

Rotate bayonet ring (1) counterclockwise. Pull out CVT unit harness connector (2) upward and remove it.

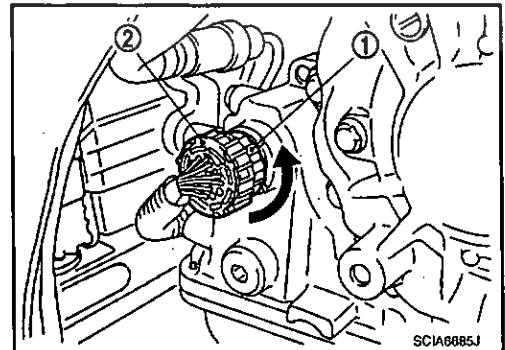
**INSTALLATION**

1. Align  $\Delta$  marking on CVT unit harness connector terminal body with  $\square$  marking on bayonet ring. Insert CVT unit harness connector. Then rotate bayonet ring clockwise.

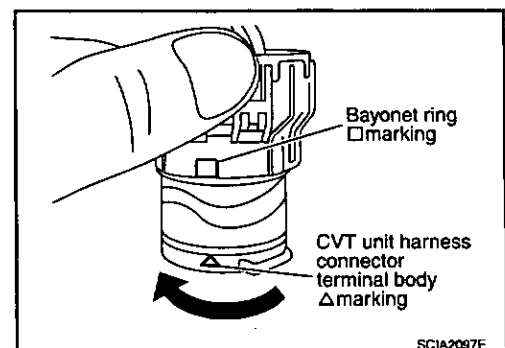

PRECAUTIONS

[CVT: RE0F10A]

< PRECAUTION >

2. Rotate bayonet ring clockwise until Δ marking on CVT unit harness connector terminal body is aligned with the slit on bayonet ring as shown in the figure (correctly fitting condition). Install CVT unit harness connector to CVT unit harness connector terminal body.

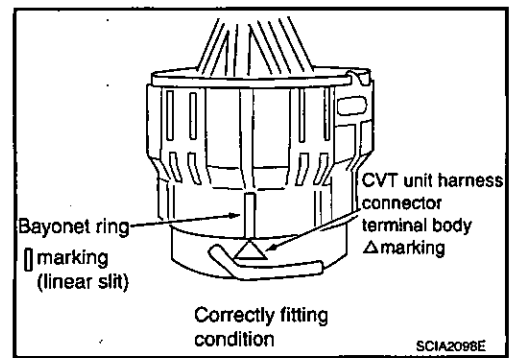

CAUTION:

- Securely align Δ marking on CVT unit harness connector terminal body with bayonet ring slit. Then, be careful not to make a half fit condition as shown in the figure.
- Never mistake the slit of bayonet ring for other dent portion.

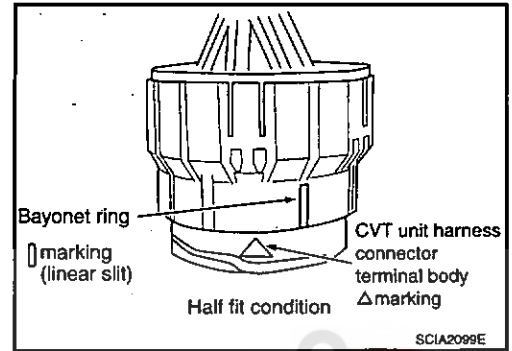

Precaution

NOTE:

If any malfunction occurs in the RE0F10A model transaxle, replace the entire transaxle assembly.

- Turn ignition switch OFF and disconnect negative battery cable before connecting or disconnecting the TCM harness connector. Because battery voltage is applied to TCM even if ignition switch is turned OFF.

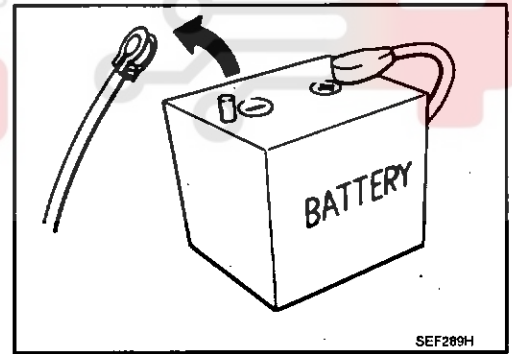

- When connecting or disconnecting pin connectors into or from TCM, do not damage pin terminals (bend or break). Check that there are not any bends or breaks on TCM pin terminal, when connecting pin connectors.

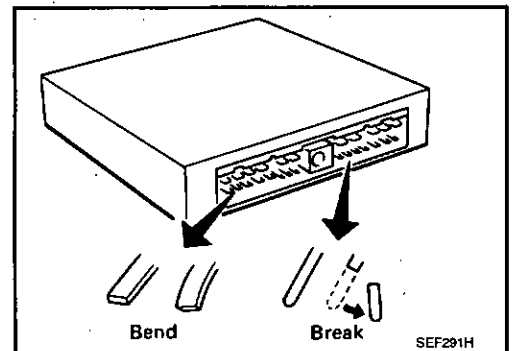

A  
B  
C  
TM  
E  
F  
G  
H  
I  
J  
K  
L  
M  
N  
O  
P

## PRECAUTIONS

## &lt; PRECAUTION &gt;

[CVT: RE0F10A]

- Perform TCM input/output signal inspection and check whether TCM functions normally or not before replacing TCM. Refer to TM-42, "Reference Value".

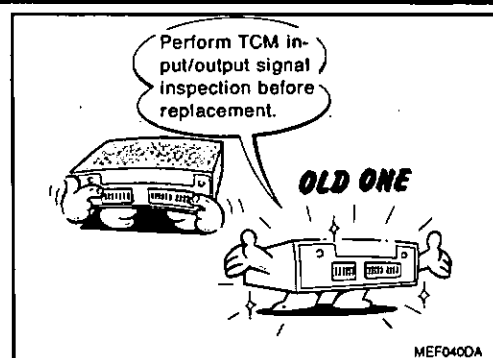

- Always use the specified brand of CVT fluid. Refer to MA-13, "Fluids and Lubricants".
- Use lint-free paper, not cloth rags, during work.
- Dispose of the waste oil using the methods prescribed by law, ordinance, etc after replacing the CVT fluid.

## Service Notice or Precaution

INFOID:000000004905287

## OBD SELF-DIAGNOSIS

- CVT self-diagnosis is performed by the TCM in combination with the ECM. The results can be read through the blinking pattern of the Malfunction Indicator Lamp (MIL).
- The self-diagnostic results indicated by the MIL are automatically stored in both the ECM and TCM memories.

Always perform the procedure on TM-36, "Diagnosis Description" to complete the repair and avoid unnecessary blinking of the MIL.

For details of OBD, refer to EC-73, "Diagnosis Description" [WITH OBD (MR TYPE1)].

- Certain systems and components, especially those related to OBD, may use the new style slide-locking type harness connector. For description and how to disconnect, refer to PG-80.

شرکت دیجیتال خودرو سامانه (مسئولیت محدود)

اولین سامانه دیجیتال تعمیرکاران خودرو در ایران

PREPARATION

< PREPARATION >

[CVT: RE0F10A]

PREPARATION

PREPARATION

Special Service Tools

INFOID:0000000004905289

Tool number Tool name	Description
1. ST25054000 Adapter 2. ST25055000 Adapter	Measuring line pressure
KV31103600 Joint pipe adapter (With ST25054000)	Measuring line pressure
<p>Commercial Service Tools</p>	
Tool number Tool name	Description
Power tool	Loosening nuts and bolts
Oil pressure gauge set 1. Oil pressure gauge 2. Hose 3. Joint pipe	Measuring line pressure
31197CA000 Drive plate location guide a: 14 mm (0.55 in) dia.	Installing transaxle assembly



SCIA8372J

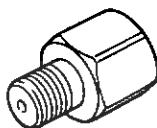

ZZA1227D

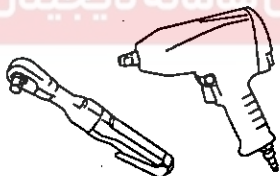

PBIC0190E

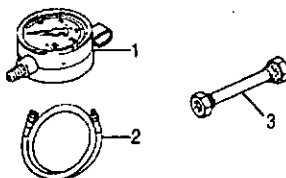

SCIA8373J

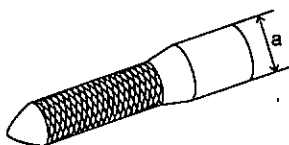

SCIA2013E

## PREPARATION

&lt; PREPARATION &gt;

[CVT: RE0F10A]

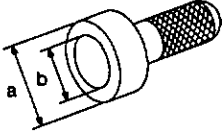
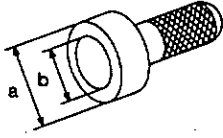
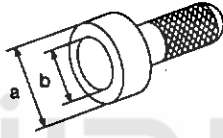
Tool number Tool name	Description
Drift a: 54 mm (2.13 in) dia. b: 47 mm (1.85 in) dia.  NT116	Installing differential side oil seal
Drift a: 70 mm (2.76 in) dia. b: 56 mm (2.20 in) dia.  NT115	Installing side oil seal (transfer joint)
Drift a: 65 mm (2.56 in) dia. b: 60 mm (2.36 in) dia.  NT115	Installing converter housing oil seal

شرکت دیجیتال خودرو (مسئولیت محدود)

اولین سامانه دیجیتال تعمیرکاران خودرو در ایران



## ON-VEHICLE MAINTENANCE

## CVT FLUID

## Inspection

INFOID:000000004905291

## CHECKING CVT FLUID

The fluid level should be checked with the fluid warmed up to 50 to 80°C (122 to 176°F). The fluid level check procedure is as follows:

1. Check for fluid leakage.
2. With the engine warmed up, drive the vehicle in an urban area. When ambient temperature is 20°C (68°F), it takes about 10 minutes for the CVT fluid to warm up to 50 to 80°C (122 to 176°F).
3. Park the vehicle on a level surface.
4. Apply parking brake firmly.
5. With engine at idle, while depressing brake pedal, move shift selector throughout the entire shift range.

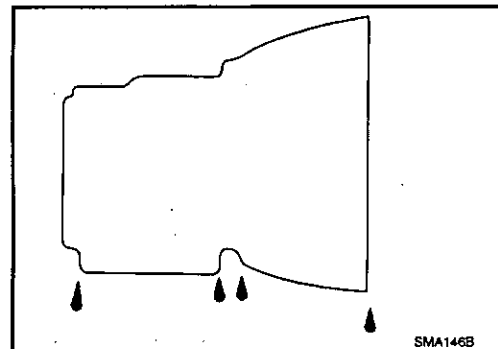

6. Pull out the CVT fluid level gauge from the CVT fluid charging pipe after pressing the tab on the CVT fluid level gauge to release the lock.

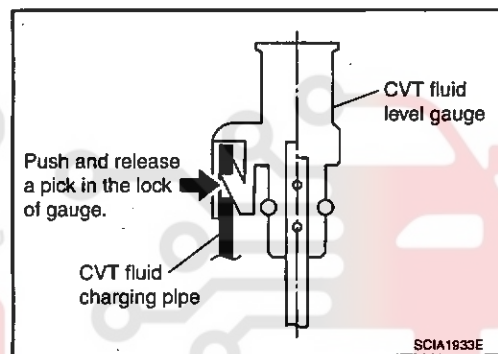

7. Wipe fluid off the CVT fluid level gauge. Insert the CVT fluid level gauge rotating 180° from the originally installed position, then securely push the CVT fluid level gauge until it meets the top end of the CVT fluid charging pipe.

**CAUTION:**

When wiping away the CVT fluid level gauge, always use lint-free paper, not a cloth rag.

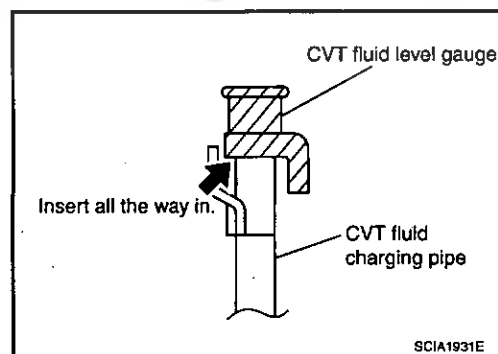

8. Place the selector lever in "P" or "N" and check that the fluid level is within the specified range.

**CAUTION:**

When reinstalling CVT fluid level gauge, insert it into the CVT fluid charging pipe and rotate it to the original installation position until securely locked.

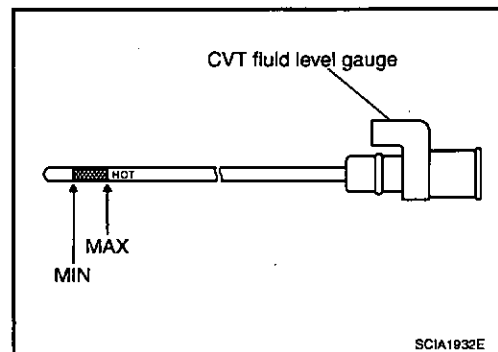

## CVT FLUID CONDITION

## CVT FLUID

&lt; ON-VEHICLE MAINTENANCE &gt;

[CVT: RE0F10A]

Check CVT fluid condition.

- If CVT fluid is very dark or smells burned, check operation of CVT. Flush cooling system after repair of CVT.
- If CVT fluid contains frictional material (clutches, brakes, etc.), replace radiator and flush cooler line using cleaning solvent and compressed air after repair of CVT. Refer to CO-34, "Exploded View".

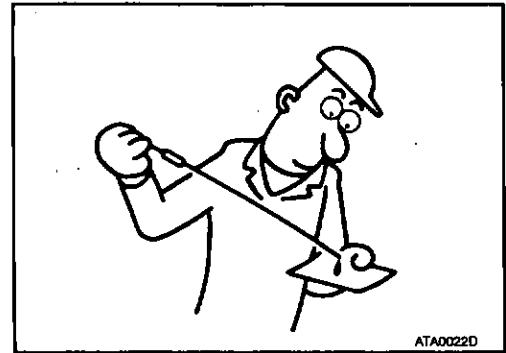

Fluid status	Conceivable cause	Required operation
Varnished (viscous varnish state)	CVT fluid become degraded due to high temperatures.	Replace the CVT fluid and check the CVT main unit and the vehicle for malfunctions (wire harnesses, cooler pipes, etc.)
Milky white or cloudy	Water in the fluid	Replace the CVT fluid and check for places where water is getting in.
Large amount of metal powder mixed in	Unusual wear of sliding parts within CVT	Replace the CVT fluid and check for improper operation of the CVT.

## Changing

INFOID:000000004905292

1. Remove drain plug, and then drain CVT fluid from oil pan.
2. Install drain plug to oil pan.

**CAUTION:****Never reuse drain plug gasket.****Drain plug – tightening torque : Refer to TM-85, "Exploded View".**

3. Fill CVT fluid from CVT fluid charging pipe to the specified level.

**CVT fluid : Refer to TM-115, "General Specification".****Fluid capacity : Refer to TM-115, "General Specification".****CAUTION:**

- Use only Genuine NISSAN CVT Fluid NS-2. Never mix with other fluid.
  - Using CVT fluid other than Genuine NISSAN CVT Fluid NS-2 will deteriorate in driveability and CVT durability, and may damage the CVT, which is not covered by the warranty.
  - When filling CVT fluid, take care not to scatter heat generating parts such as exhaust.
  - Sufficiently shake the container of CVT fluid before using.
4. With the engine warmed up, drive the vehicle in an urban area. When ambient temperature is 20°C (68°F), it takes about 10 minutes for the CVT fluid to warm up to 50 to 80°C (122 to 176°F).
  5. Check CVT fluid level and condition.
  6. Repeat steps 1 to 5 if CVT fluid has been contaminated.

**STALL TEST**

< ON-VEHICLE MAINTENANCE >

[CVT: RE0F10A]

**STALL TEST**

**Inspection and Judgment**

INFOID:000000004905293

**INSPECTION**

1. Inspect the amount of engine oil. Replenish the engine oil if necessary.
2. Drive for about 10 minutes to warm up the vehicle so that the CVT fluid temperature is 50 to 80°C (122 to 176°F). Inspect the amount of CVT fluid. Replenish if necessary.

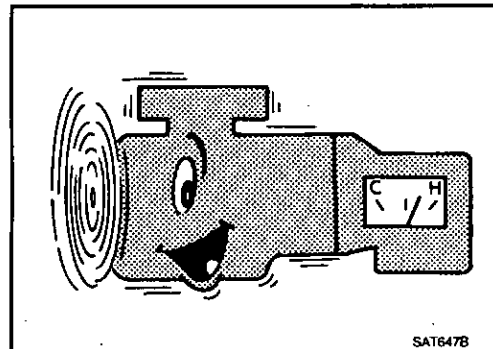

3. Securely engage the parking brake so that the tires do not turn.
4. Install a tachometer where it can be seen by driver during test.  
**NOTE:**  
It is good practice to mark the point of specified engine rpm on indicator.

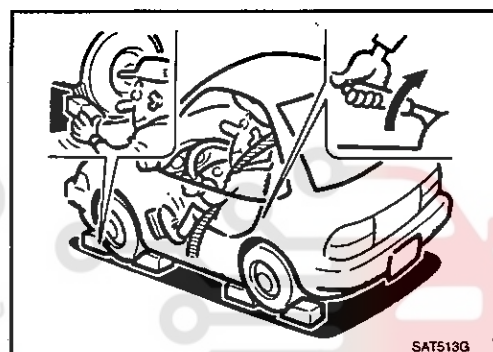

5. Start engine, apply foot brake, and place selector lever in "D" position.

6. While holding down the foot brake, gradually press down the accelerator pedal.
7. Quickly read off the stall speed, and then quickly remove your foot from the accelerator pedal.

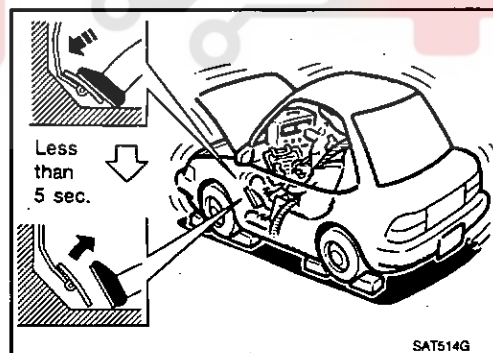

**CAUTION:**  
Never hold down the accelerator pedal for more than 5 seconds during this test.

**Stall speed** : Refer to TM-115, "Stall Speed".

8. Move the selector lever to the "N" position.
9. Cool down the CVT fluid.  
**CAUTION:**  
Run the engine at idle for at least 1 minute.
10. Repeat steps 6 through 9 with selector lever in "R" position.

**JUDGMENT**

	Selector lever position		Expected problem location
	"D"	"R"	
Stall rotation	H	O	• Forward clutch
	O	H	• Reverse brake
	L	L	• Engine and torque converter one-way clutch
	H	H	• Line pressure low • Primary pulley • Secondary pulley • Steel belt

A  
B  
C  
TM  
E  
F  
G  
H  
I  
J  
K  
L  
M  
N  
O  
P

STALL TEST

< ON-VEHICLE MAINTENANCE >

[CVT: RE0F10A]

O: Stall speed within standard value position.

H: Stall speed is higher than standard value.

L: Stall speed is lower than standard value.

دیجیتال خودرو

شرکت دیجیتال خودرو سامانه (مسئولیت محدود)

اولین سامانه دیجیتال تعمیرکاران خودرو در ایران



LINE PRESSURE TEST

< ON-VEHICLE MAINTENANCE >

[CVT: RE0F10A]

LINE PRESSURE TEST

Inspection and Judgment

INFOID.000000004905294

INSPECTION

Line Pressure Test Port

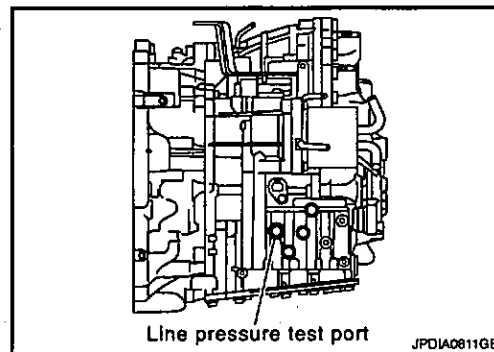

Line Pressure Test Procedure

1. Inspect the amount of engine oil and replenish if necessary.
2. Drive the car for about 10 minutes to warm it up so that the CVT fluid reaches in the range of 50 to 80°C (122 to 176°F), then inspect the amount of CVT fluid and replenish if necessary.

**NOTE:**

The CVT fluid temperature rises in the range of 50 to 80°C (122 to 176°F) during 10 minutes of driving.

3. After warming up CVT, remove the oil pressure detection plug and install the joint pipe adapter (SST: KV31103600) (A), adapter (SST: 25054000) (B), oil pressure gauge set (commercial service tool) (C).

**CAUTION:**

When using the oil pressure gauge, be sure to use the O-ring attached to the oil pressure detection plug.

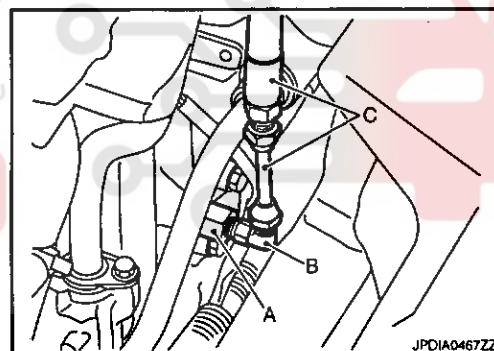

4. Securely engage the parking brake so that the tires do not turn.

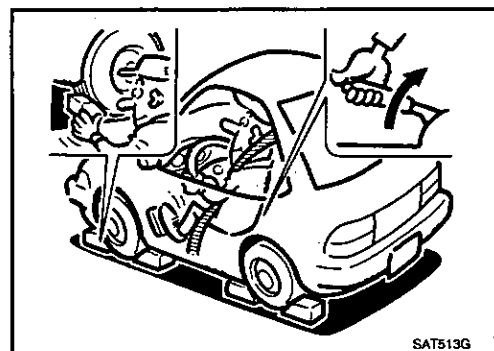

A  
B  
C  
TM  
E  
F  
G  
H  
I  
J  
K  
L  
M  
N  
O  
P

LINE PRESSURE TEST

< ON-VEHICLE MAINTENANCE >

[CVT: RE0F10A]

5. Start the engine, and then measure the line pressure at both idle and the stall speed.

**CAUTION:**

- Keep the brake pedal pressed all the way down during measurement.
- When measuring the line pressure at the stall speed, refer to TM-67, "Inspection and Judgment".

6. After the measurements are complete, install the oil pressure detection plug and tighten to the specified torque below.

 : 7.5 N·m (0.77 kg-m, 66 in-lb)

**CAUTION:**

- Never reuse O-ring.
- Apply CVT fluid to O-ring.

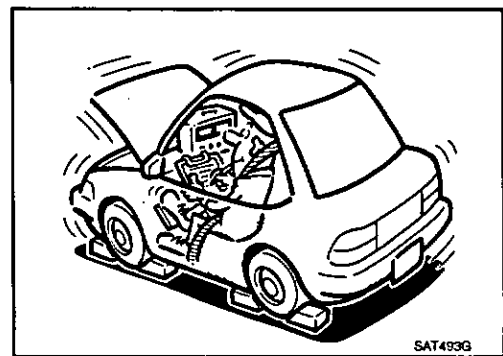

Line Pressure

kPa (bar, kg/cm<sup>2</sup>, psi)

Engine speed	Line pressure
	"R" and "D" positions
At idle	750 (7.50, 7.65, 108.8)
At stall	5,700 (57.00, 58.14, 826.5)*

\*: Reference values

JUDGMENT

Judgment	Possible cause
Idle speed	Possible causes include malfunctions in the pressure supply system and low oil pump output. For example <ul style="list-style-type: none"> <li>• Oil pump wear</li> <li>• Pressure regulator valve or plug sticking or spring fatigue</li> <li>• Oil strainer ⇒ oil pump ⇒ pressure regulator valve passage oil leak</li> <li>• Engine idle speed too low</li> </ul>
	Only low for a specific position Possible causes include an oil pressure leak in a passage or device related to the position after the pressure is distributed by the manual valve.
	High Possible causes include a sensor malfunction or malfunction in the line pressure adjustment function. For example <ul style="list-style-type: none"> <li>• Accelerator pedal position signal malfunction</li> <li>• CVT fluid temperature sensor malfunction</li> <li>• Pressure control solenoid A (line pressure solenoid) malfunction (sticking in OFF state, filter clog, cut line)</li> <li>• Pressure regulator valve or plug sticking</li> </ul>
Stall speed	Line pressure does not rise higher than the line pressure for idle. Possible causes include a sensor malfunction or malfunction in the pressure adjustment function. For example <ul style="list-style-type: none"> <li>• Accelerator pedal position signal malfunction</li> <li>• TCM malfunction</li> <li>• Pressure control solenoid A (line pressure solenoid) malfunction (shorting, sticking in ON state)</li> <li>• Pressure regulator valve or plug sticking</li> </ul>
	The pressure rises, but does not enter the standard position. Possible causes include malfunctions in the pressure supply system and malfunction in the pressure adjustment function. For example <ul style="list-style-type: none"> <li>• Accelerator pedal position signal malfunction</li> <li>• Pressure control solenoid A (line pressure solenoid) malfunction (sticking, filter clog)</li> <li>• Pressure regulator valve or plug sticking</li> </ul>
	Only low for a specific position Possible causes include an oil pressure leak in a passage or device related to the position after the pressure is distributed by the manual valve.

ROAD TEST

Description

INFOID:000000004905295

DESCRIPTION

- The purpose of the test is to determine the overall performance of CVT and analyze causes of problems.
- The road test consists of the following three parts:
  1. "Check Before Engine Is Started" TM-71.
  2. "Check at Idle" TM-71.
  3. "Cruise Test" TM-72.

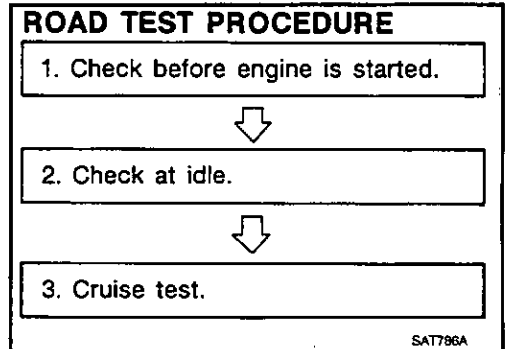

- Before the road test, familiarize yourself with all test procedures and items to check.
- Perform tests on all items until specified symptom is found. Troubleshoot items which check out No Good after road test.



Check before Engine Is Started

INFOID:000000004905296

1. CHECK SHIFT POSITION INDICATOR

1. Park vehicle on level surface.
2. Move selector lever to "P" position.
3. Turn ignition switch OFF. Wait at least 5 seconds.
4. Turn ignition switch ON. (Do not start engine.)

Has shift position indicator been turned ON for about 2 seconds?

- YES >> 1. Turn ignition switch OFF.  
 2. Go to TM-71, "Check at Idle".
- NO >> Stop "Road Test". Refer to TM-48, "Symptom Table".

Check at Idle

INFOID:000000004905297

1. CHECK STARTING THE ENGINE

1. Park vehicle on flat surface.
2. Move selector lever to "P" or "N" position.
3. Turn ignition switch OFF.
4. Turn ignition switch to "START" position.

Is engine started?

- YES >> GO TO 2.
- NO >> Stop "Road Test". Refer to TM-48, "Symptom Table".

2. CHECK STARTING THE ENGINE

1. Turn ignition switch ON.
2. Move selector lever to "D", "M" or "R" position.
3. Turn ignition switch to "START" position.

Is engine started?

## ROAD TEST

## &lt; ON-VEHICLE MAINTENANCE &gt;

[CVT: RE0F10A]

- YES >> Stop "Road Test". Refer to TM-48, "Symptom Table".  
 NO >> GO TO 3.

**3.CHECK "P" POSITION FUNCTION**

1. Move selector lever to "P" position.
2. Turn ignition switch OFF.
3. Release parking brake.
4. Push vehicle forward or backward.
5. Apply parking brake.

Does vehicle move forward or backward?

- YES >> Refer to TM-48, "Symptom Table". GO TO 4.  
 NO >> GO TO 4.

**4.CHECK "N" POSITION FUNCTION**

1. Start engine.
2. Move selector lever to "N" position.
3. Release parking brake.

Does vehicle move forward or backward?

- YES >> Refer to TM-48, "Symptom Table". GO TO 5.  
 NO >> GO TO 5.

**5.CHECK SHIFT SHOCK**

1. Apply foot brake.
2. Move selector lever to "R" position.

Is there large shock when changing from "N" to "R" position?

- YES >> Refer to TM-48, "Symptom Table". GO TO 6.  
 NO >> GO TO 6.

**6.CHECK "R" POSITION FUNCTION**

Release foot brake for several seconds.

Does vehicle creep backward when foot brake is released?

- YES >> GO TO 7.  
 NO >> Refer to TM-48, "Symptom Table". GO TO 7.

**7.CHECK "D" POSITION FUNCTION**

Move selector lever to "D" position and check if vehicle creeps forward.

Does vehicle creep forward in all positions?

- YES >> Go to TM-72, "Cruise Test".  
 NO >> Stop "Road Test". Refer to TM-48, "Symptom Table".

**Cruise Test**

INFOID:000000004905288

**1.CHECK VEHICLE SPEED WHEN SHIFTING GEARS — PART 1**

1. Drive vehicle for approximately 10 minutes to warm engine oil and CVT fluid up to operating temperature.

**CVT fluid operating temperature: 50 – 80°C (122 – 176°F)**

2. Park vehicle on flat surface.
3. Move selector lever to "P" position.
4. Start engine.
5. Move selector lever to "D" position.



## ROAD TEST

## &lt; ON-VEHICLE MAINTENANCE &gt;

[CVT: RE0F10A]

6. Accelerate vehicle at 2/8 throttle opening and check "Vehicle Speed When Shifting Gears".

Is the inspection result normal?

- YES >> GO TO 2.  
NO >> Refer to TM-48, "Symptom Table". GO TO 2.

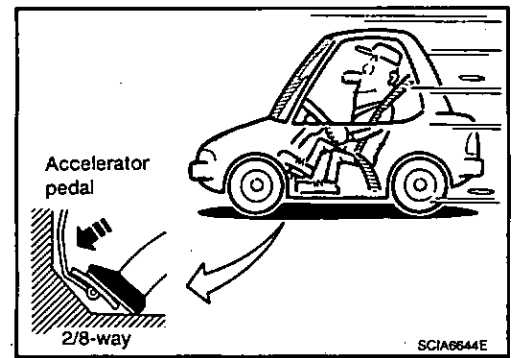

## 2. CHECK VEHICLE SPEED WHEN SHIFTING GEARS — PART 2

1. Park vehicle on flat surface.
2. Move selector lever to "D" position.
3. Accelerate vehicle at 8/8 throttle opening and check "Vehicle Speed When Shifting Gears".

Is the inspection result normal?

- YES >> GO TO 3.  
NO >> Refer to TM-48, "Symptom Table". GO TO 3.

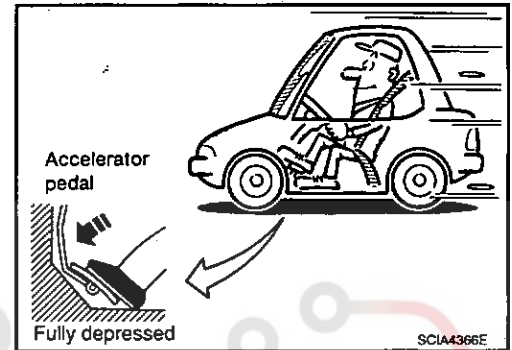

## 3. CHECK MANUAL MODE FUNCTION

Move to manual mode from "D" position.

Does it switch to manual mode?

- YES >> GO TO 4.  
NO >> Refer to TM-48, "Symptom Table". GO TO 4.

## 4. CHECK SHIFT-UP FUNCTION

During manual mode driving, is upshift from M1 → M2 → M3 → M4 → M5 → M6 performed?

Is upshifting correctly performed?

- YES >> GO TO 5.  
NO >> Refer to TM-48, "Symptom Table". GO TO 5.

## 5. CHECK SHIFT-DOWN FUNCTION

During manual mode driving, is downshift from M6 → M5 → M4 → M3 → M2 → M1 performed?

Is downshifting correctly performed?

- YES >> GO TO 6.  
NO >> Refer to TM-48, "Symptom Table". GO TO 6.

## 6. CHECK ENGINE BRAKE FUNCTION

Check engine brake.

Does engine braking effectively reduce vehicle speed in "M1" position?

- YES >> 1. Stop the vehicle.  
2. End of "Road Test".  
NO >> Refer to TM-48, "Symptom Table". Then continue trouble diagnosis.

## CVT POSITION

## Inspection and Adjustment

INFOID:0000000004905299

## INSPECTION

1. Place selector lever in "P" position, and turn ignition switch ON (engine stop).
2. Check that selector lever can be shifted to other than "P" position when brake pedal is depressed. Also check that selector lever can be shifted from "P" position only when brake pedal is depressed.
3. Move the selector lever and check for excessive effort, sticking, noise or rattle.
4. Check that selector lever stops at each position with the feel of engagement when it is moved through all the positions. Check that the actual position of the selector lever matches the position shown by the shift position indicator and the manual lever on the transaxle.
5. The method of operating the selector lever to individual positions correctly should be as shown.
6. When selector button is pressed in "P", "R", or "N" position without applying forward/backward force to selector lever, check button operation for sticking.
7. Check that back-up lamps illuminate only when selector lever is placed in the "R" position. Check that back-up lamps do not illuminate when the selector lever is pushed toward the "R" position when in the "P" or "N" position.
8. Check that engine can only be started with the selector lever in the "P" and "N" positions.
9. Check that transaxle is locked completely in "P" position.
10. When selector lever is set to manual shift gate, check that manual mode is displayed on combination meter.  
Shift selector lever to "+" and "-" sides, and check that set shift position changes.

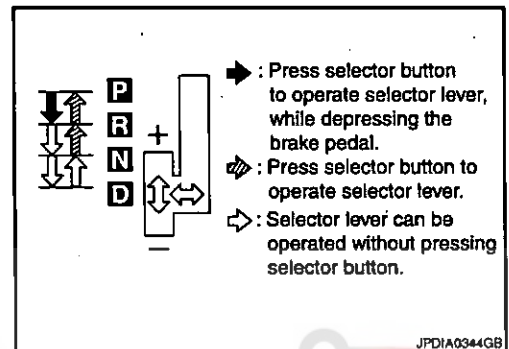

## ADJUSTMENT

1. Place selector lever in "P" position.  
**CAUTION:**  
Turn wheels more than 1/4 rotations and apply the park lock.
2. Loosen nut (A) and place manual lever (B) in "P" position.  
**CAUTION:**  
Never apply any force to the manual lever.
3. Tighten nut. Refer to TM-80, "Exploded View".  
**CAUTION:**  
Fix the manual lever when tightening.

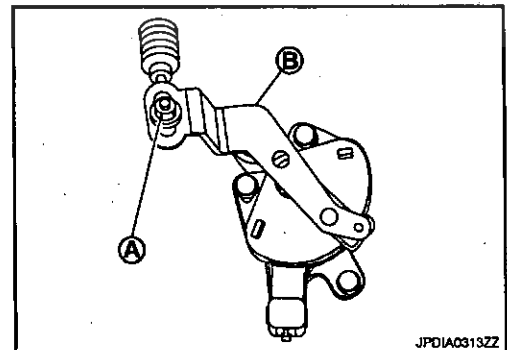

ON-VEHICLE REPAIR  
TRANSMISSION CONTROL MODULE

Exploded View

INFOID:000000004905300

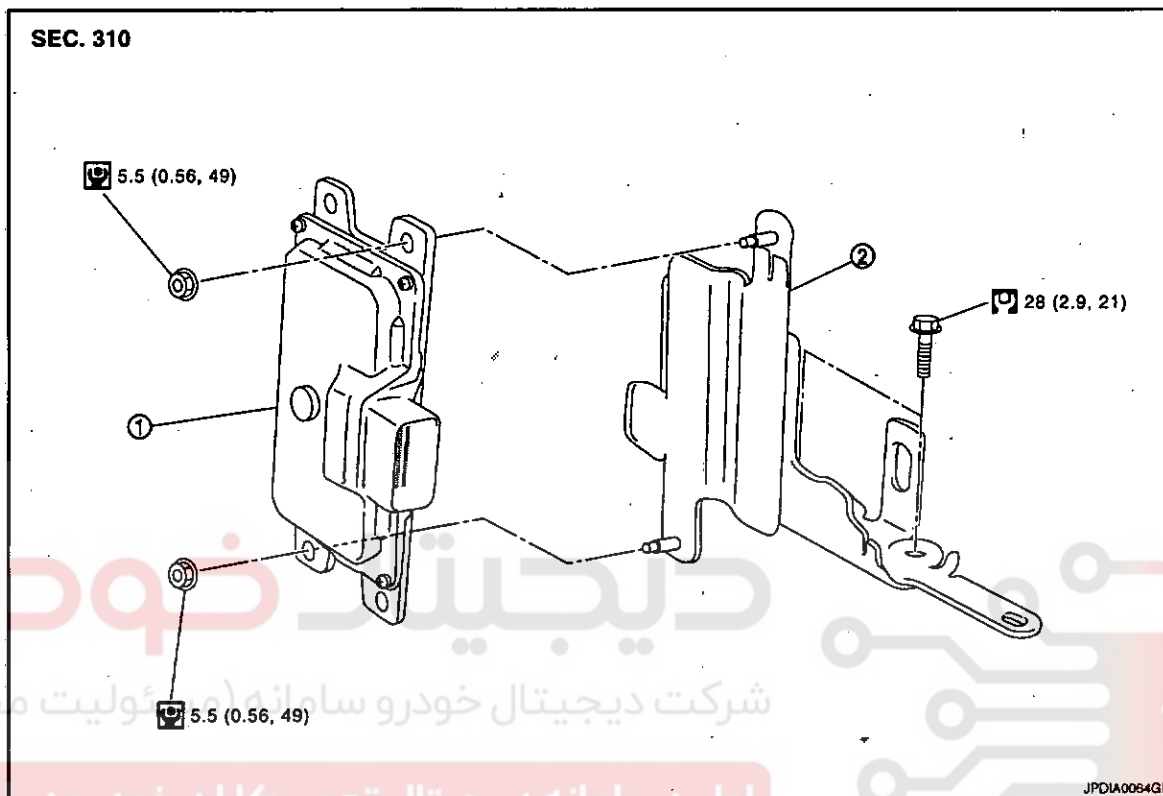

- 1. TCM
- 2. Bracket

Refer to GI-3, "Components" for symbols in the figure.

Removal and Installation

INFOID:000000004905301

REMOVAL

CAUTION:

Never impact on TCM when removing or installing TCM.

1. Disconnect the battery cable from negative terminal.
2. Remove the Air duct (inlet). Refer to EM-146, "Exploded View".
3. Disconnect the TCM harness connector (A).

↔ : Vehicle front

← : Nut

1 : Battery

4. Remove the TCM (2) from the bracket (3).

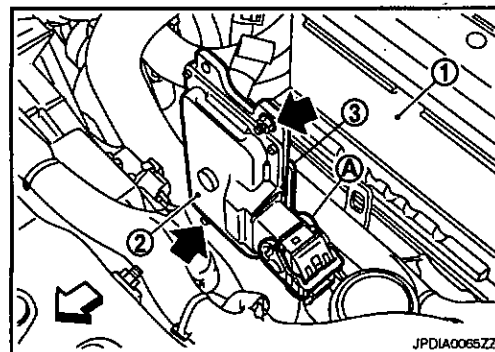

INSTALLATION

Install in the reverse order of removal.

CONTROL DEVICE

Exploded View

INFOID:000000004905302

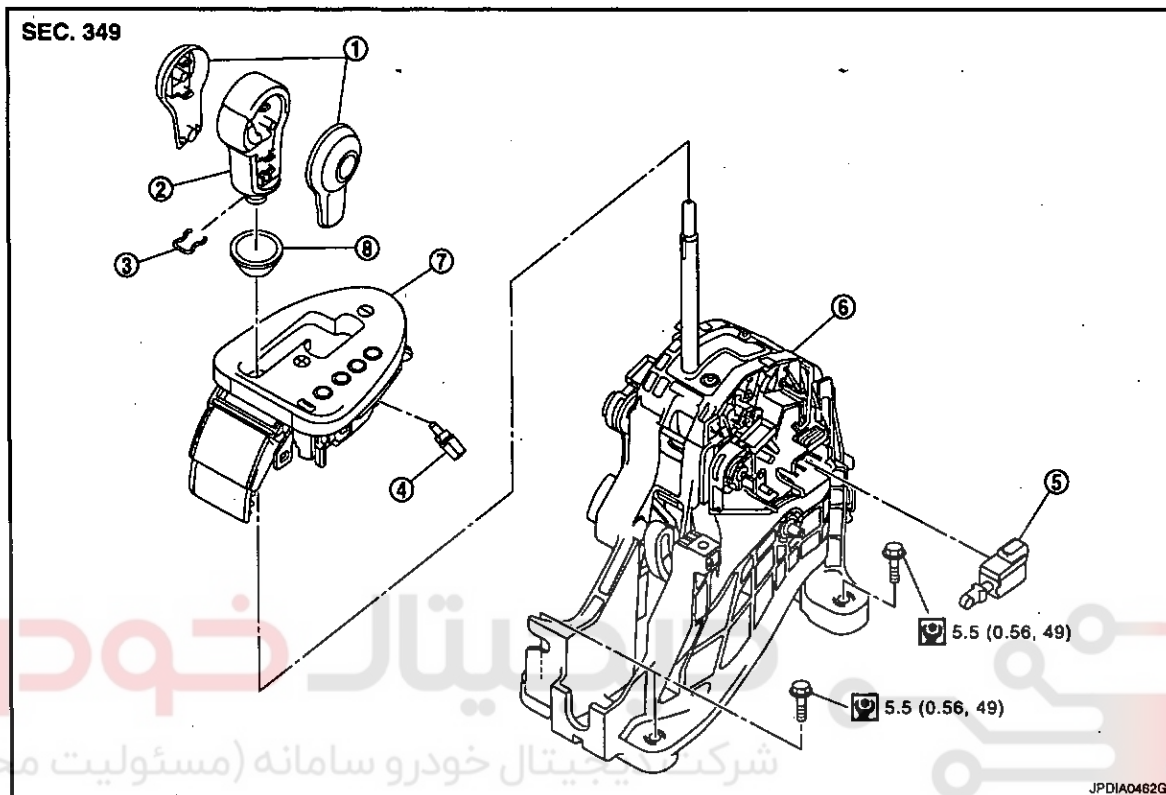

- |                             |                        |                            |
|-----------------------------|------------------------|----------------------------|
| 1. Knob fin                 | 2. Selector lever knob | 3. Lock pin                |
| 4. Position lamp            | 5. Shift lock solenoid | 6. Control device assembly |
| 7. Position indicator plate | 8. Knob cover          |                            |

Refer to GI-3, "Components" for symbols in the figure.

Removal and Installation

INFOID:000000004905303

REMOVAL

1. Disconnect the battery cable from the negative terminal.
  2. Move selector lever to "N" position.
  3. Remove knob cover (1) below selector lever downward.
- CAUTION:**  
Be careful not to damage the knob cover.
4. Pull lock pin (2) out of selector lever knob (3).
  5. Remove selector lever knob and knob cover.

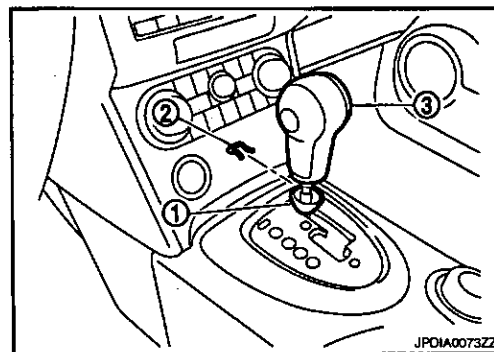

## CONTROL DEVICE

## &lt; ON-VEHICLE REPAIR &gt;

[CVT: RE0F10A]

6. Remove knob fin (1) using a flat-bladed screwdriver (A).  
**CAUTION:**  
**Be careful not to damage the selector lever knob.**
7. Remove center console. Refer to IP-18, "Exploded View".

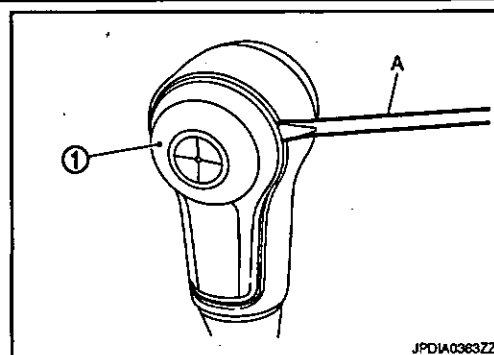

8. Remove shift lock solenoid connector (A).
9. Remove shift lock solenoid (1) using a feeler gauge (B).

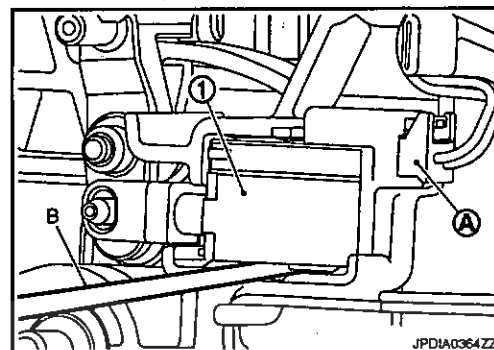

10. Disconnect control device harness connector (A).

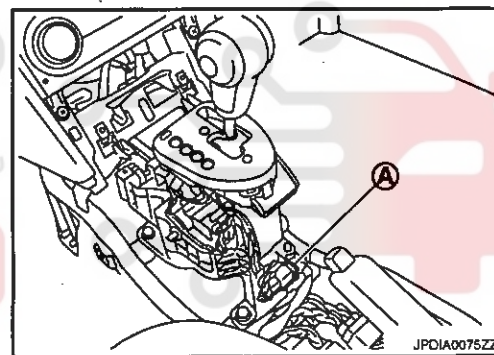

11. Move selector lever to "P" position.
12. Disconnect key interlock cable (1) from control device assembly. Refer to TM-82, "Exploded View".
13. Disconnect control cable (2) from control device assembly. Refer to TM-80, "Exploded View".

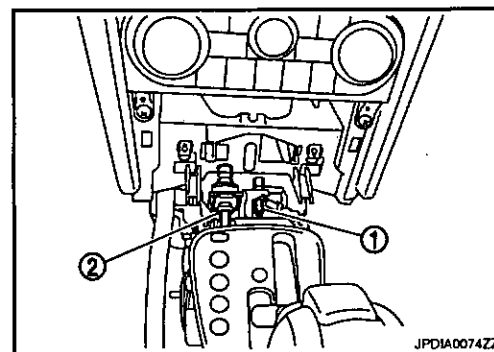

CONTROL DEVICE

< ON-VEHICLE REPAIR >

[CVT: RE0F10A]

14. Remove control device assembly.

← : Bolt

15. Remove position lamp.

16. Unhook (↔) position indicator plate (1) for removal.

• LHD

A : Driver side

B : Passenger side

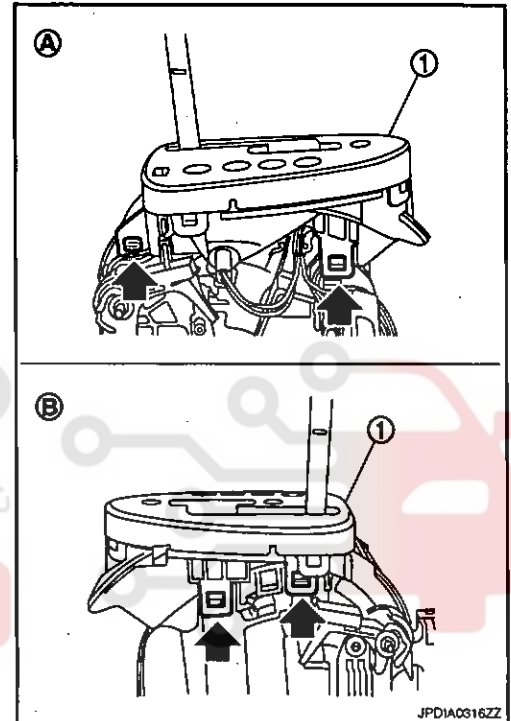
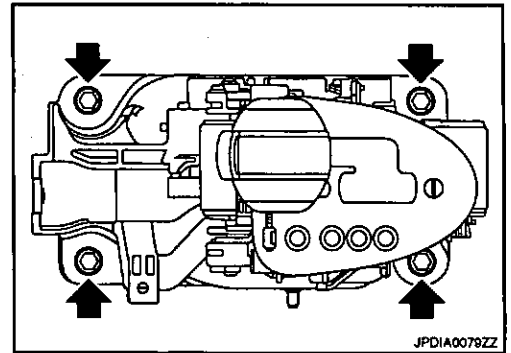

دیجیتال خودرو  
 شرکت دیجیتال خودرو سامانه (مسئولیت محدود)  
 اولین سامانه دیجیتال تعمیرکاران خودرو در ایران

CONTROL DEVICE

< ON-VEHICLE REPAIR >

[CVT: RE0F10A]

• RHD

- A : Passenger side
- B : Driver side

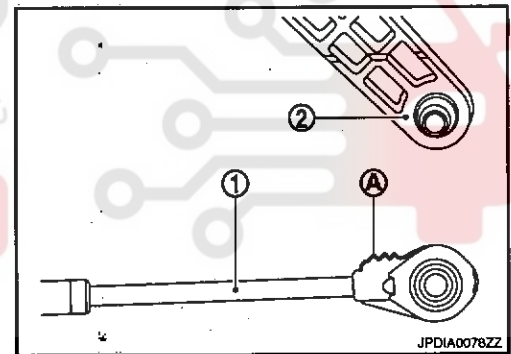
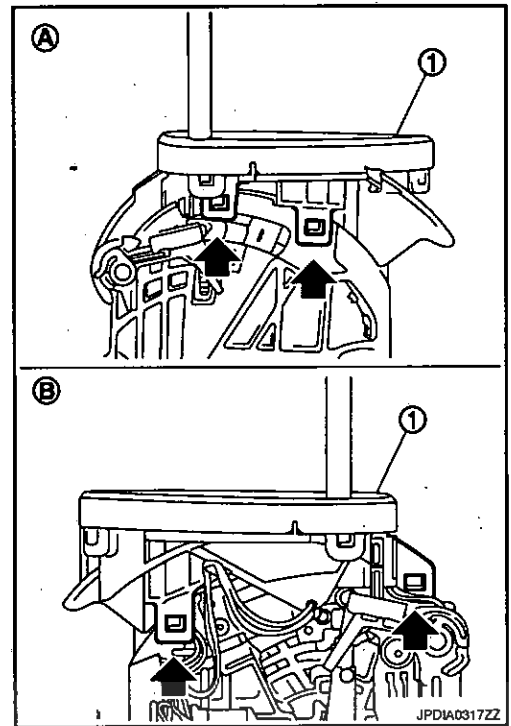

INSTALLATION

Note the following, and install in the reverse order of removal. When installing the control cable (1) to the control device assembly (2), check that the control cable is fully pressed in with the ribbed (A) surface facing upward.

شرکت دیجیتال خودرو سامانه (مستولیت محدود)

اولین سامانه دیجیتال تعمیرکاران خودرو در ایران

Inspection and Adjustment

ADJUSTMENT AFTER INSTALLATION

Adjust the CVT positions after installing the control device. Refer to TM-74, "Inspection and Adjustment".

INSPECTION AFTER INSTALLATION

Check the CVT positions after adjusting the CVT positions. Refer to TM-74, "Inspection and Adjustment".

INFOID.000000004905304

CONTROL CABLE

< ON-VEHICLE REPAIR >

[CVT: RE0F10A]

CONTROL CABLE

Exploded View

INFOID:000000004905305

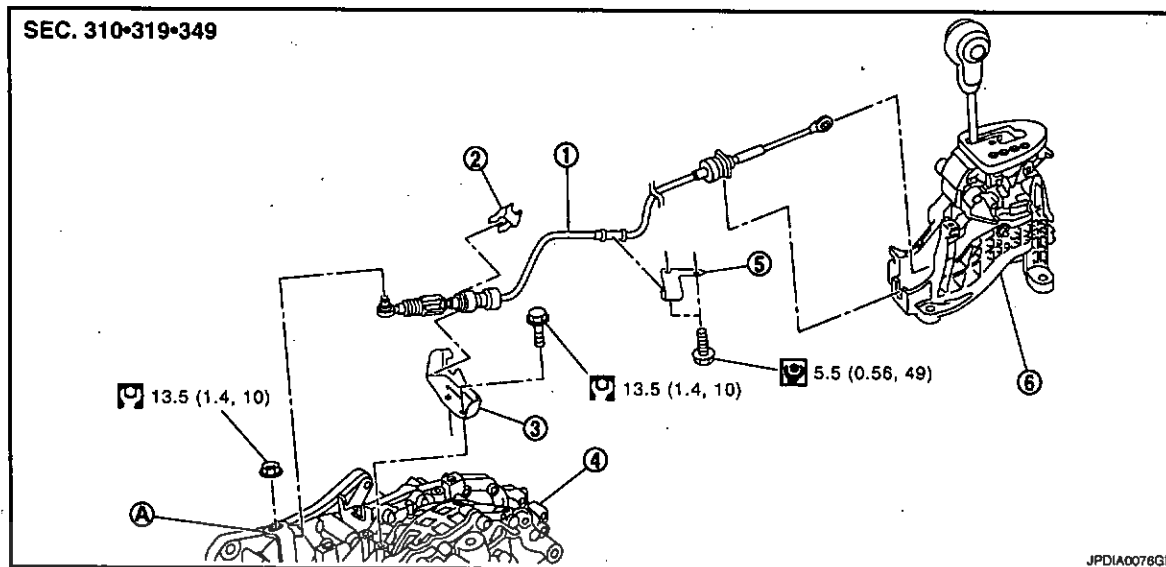

- |                       |               |                            |
|-----------------------|---------------|----------------------------|
| 1. Control cable      | 2. Lock plate | 3. Bracket                 |
| 4. Transaxle assembly | 5. Bracket    | 6. Control device assembly |
| A. Manual lever       |               |                            |

Refer to GI-3, "Components" for symbols in the figure.

Removal and Installation

INFOID:000000004905306

REMOVAL

CAUTION:

Check that parking brake is applied before removal/installation.

1. Disconnect control cable from control device assembly. Refer to TM-76, "Exploded View".
2. Remove the air cleaner assembly. Refer to EM-146, "Exploded View".
3. Remove nut (A) and control cable (1) from the manual lever (B).
4. Remove the lock plate (2) and the control cable from the bracket (3).
5. Remove exhaust front tube. Refer to EX-10, "Exploded View".
6. Separate the propeller shaft. Refer to DLN-105, "Exploded View" (4WD only).
7. Remove heat plate.

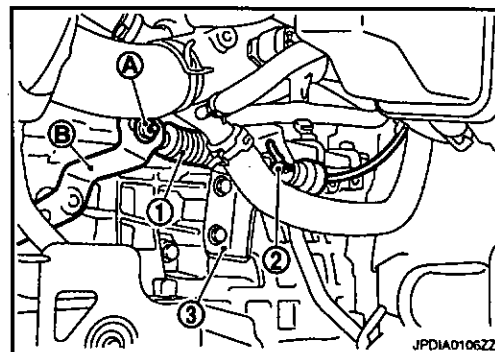



**CONTROL CABLE**

**< ON-VEHICLE REPAIR >**

[CVT: RE0F10A]

8. Remove control cable (1) from bracket (2).

↔ : Vehicle front

9. Remove the control cable from the vehicle.

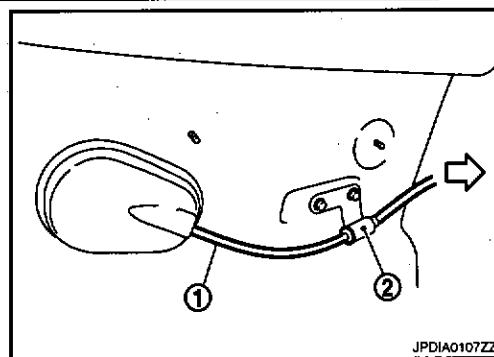

**INSTALLATION**

Note the following, and install in the reverse order of removal.

When installing the control cable (1) to the control device assembly (2), make sure that the control cable is fully pressed in with the ribbed (A) surface facing upward.

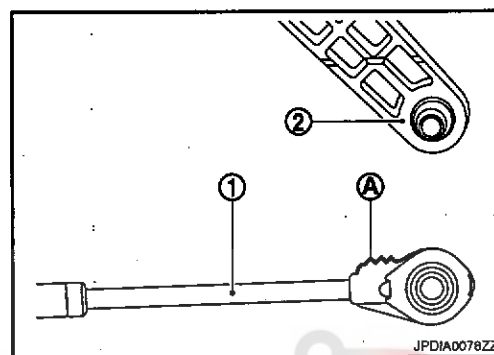

**Inspection and Adjustment**

**ADJUSTMENT AFTER INSTALLATION**

Adjust the CVT positions after installing control cable. Refer to TM-74, "Inspection and Adjustment".

**INSPECTION AFTER INSTALLATION**

Check the CVT positions after adjusting the CVT positions. Refer to TM-74, "Inspection and Adjustment".

A  
B  
C  
TM  
E  
F  
G  
H  
I  
J  
K  
L  
M  
N  
O  
P

KEY INTERLOCK CABLE

< ON-VEHICLE REPAIR >

[CVT: RE0F10A]

KEY INTERLOCK CABLE

Exploded View

INFOID:000000004905306

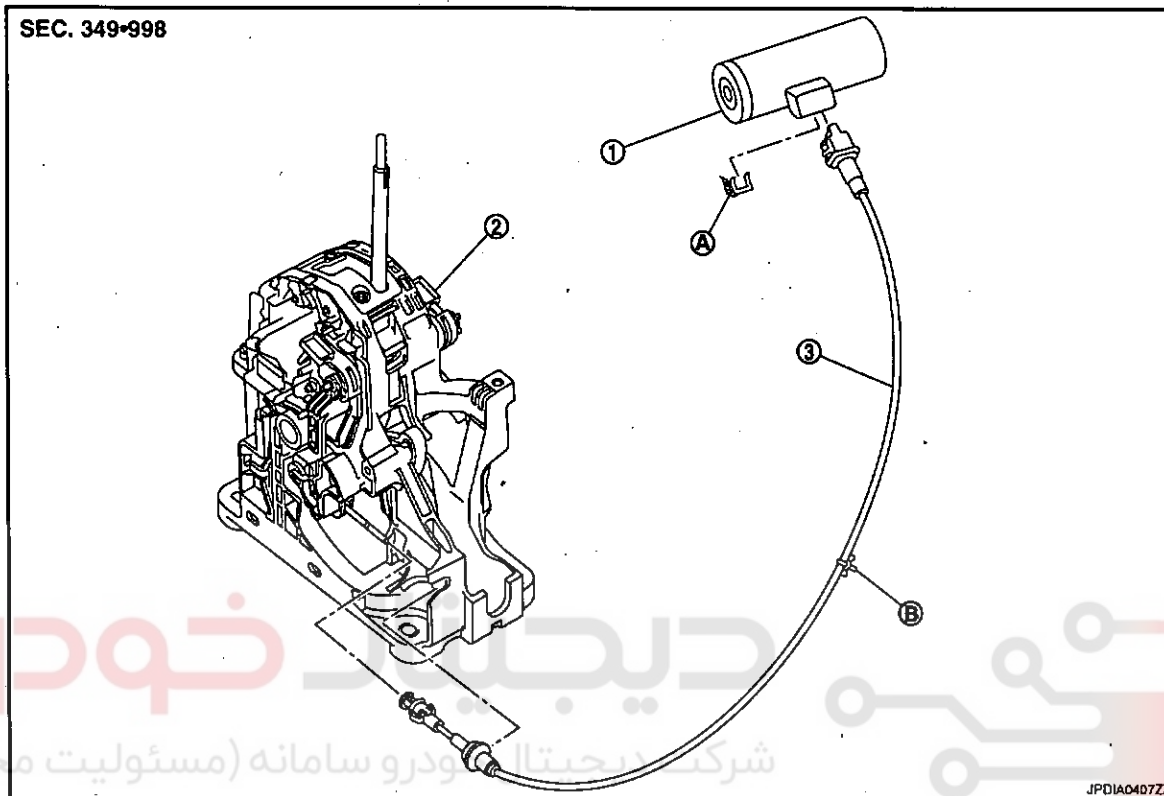

- |                 |                            |                        |
|-----------------|----------------------------|------------------------|
| 1. Key cylinder | 2. Control device assembly | 3. Key interlock cable |
| A. Clip         | B. Clip                    |                        |

Removal and Installation

INFOID:000000004905309

REMOVAL

CAUTION:

Check that parking brake is applied before removal/installation.

1. Move selector lever to "P" position.
2. Remove selector lever knob. Refer to TM-76, "Exploded View".
3. Remove center console. Refer to IP-18, "Exploded View".
4. Slide slider (A) toward casing cap (B) while pressing tabs (C) on slider to separate slider from adjust holder (D).

E : Key interlock rod

5. Remove steering column lower cover and lower instrument panel, driver side. Refer to IP-11, "Exploded View".

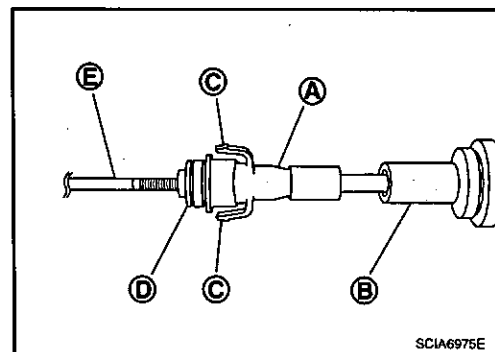

KEY INTERLOCK CABLE

[CVT: RE0F10A]

< ON-VEHICLE REPAIR >

- 6. Remove clip (A) from holder (B) and remove key interlock cable (1) from key cylinder (2).

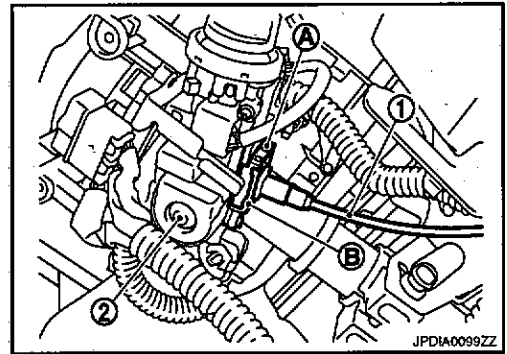

- 7. Remove clip (←) and remove key interlock cable (1).

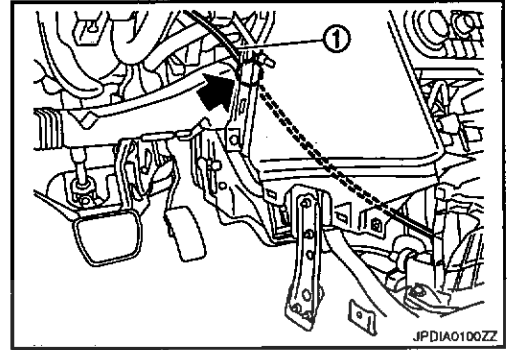

INSTALLATION

Note the following, and install in the reverse order of removal.

- Temporarily install adjust holder (A) to key interlock rod (B). Install casing cap (C) to cable bracket (D) on control device assembly.

CAUTION:

- Never bend or twist key interlock cable excessively when installing.
- Check that casing caps is firmly secured in cable bracket on control device assembly after installing key interlock cable to cable bracket on control device assembly.
- If casing cap is loose [less than 39.2 N (4.0 kg, 8.8 lb) removing force], replace key interlock cable.

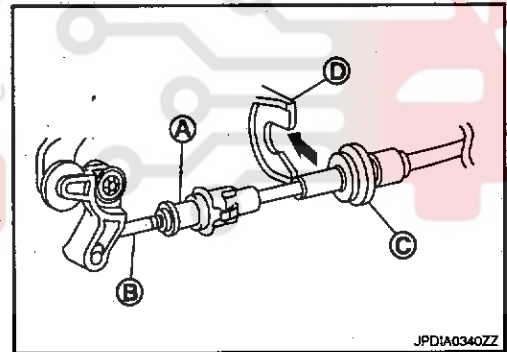

A  
B  
C  
TM  
E  
F  
G  
H  
I  
J  
K  
L  
M  
N  
O  
P

## KEY INTERLOCK CABLE

## &lt; ON-VEHICLE REPAIR &gt;

[CVT: RE0F10A]

- With the detent rod (A) pressed fully to the end, slider the key interlock cable slider (B) to the key interlock rod side (C), and install adjust holder (D) and key interlock rod.

**CAUTION:**

- Never press tabs when holding slider.
- Never apply any force at a right angle to key interlock rod when sliding.

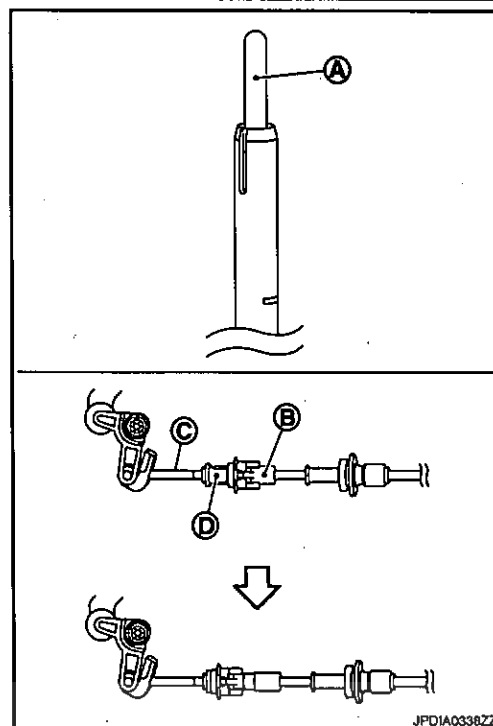

## Inspection

## INSPECTION AFTER INSTALLATION

Check the CVT positions after adjusting the CVT positions. Refer to TM-74, "Inspection and Adjustment".

شرکت دیجیتال خودرو (مسئولیت محدود)

اولین سامانه دیجیتال تعمیرکاران خودرو در ایران

OIL PAN

< ON-VEHICLE REPAIR >

[CVT: RE0F10A]

OIL PAN

Exploded View

INFOID:000000004905311

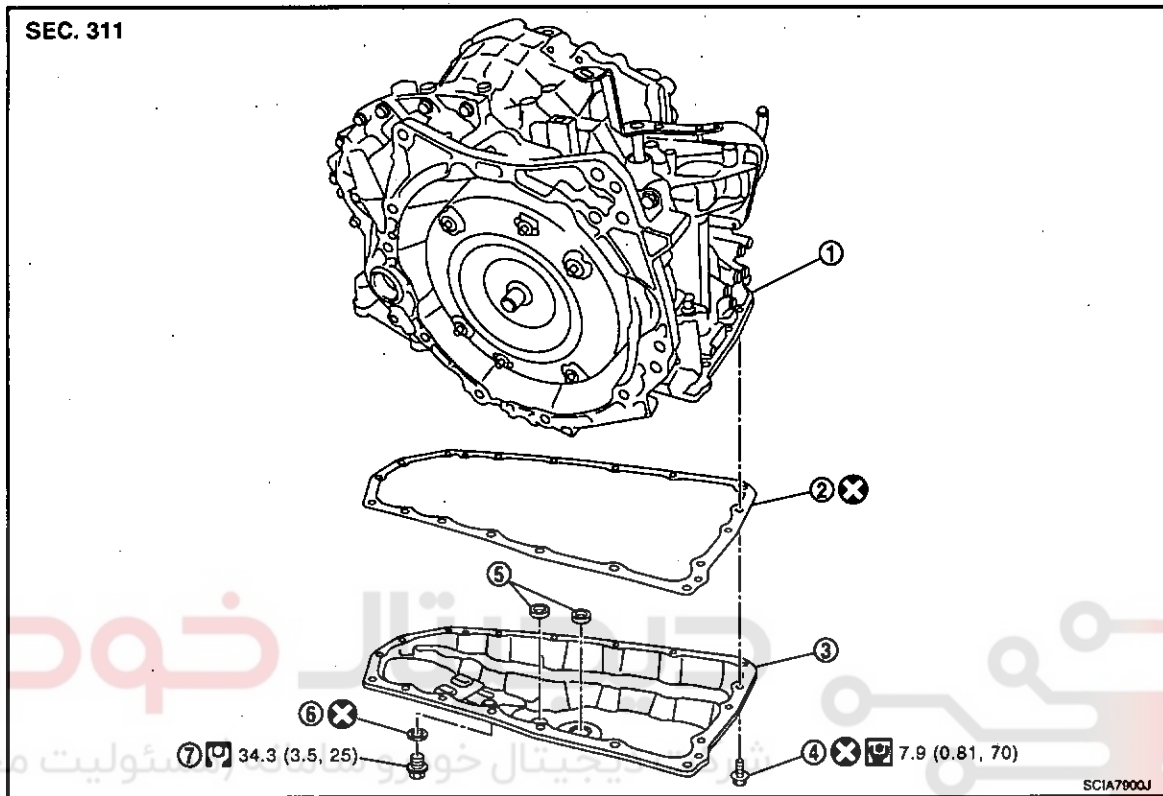

- |                         |                   |                      |
|-------------------------|-------------------|----------------------|
| 1. Transaxle assembly   | 2. Oil pan gasket | 3. Oil pan           |
| 4. Oil pan fitting bolt | 5. Magnet         | 6. Drain plug gasket |
| 7. Drain plug           |                   |                      |

Refer to GI-3, "Components" for symbols in the figure.

Removal and Installation

INFOID:000000004905312

REMOVAL

1. Remove engine under cover with power tool.
2. Remove drain plug (1), and then drain CVT fluid from oil pan.

← : Vehicle front

3. Remove oil pan fitting bolts (2).
4. Remove oil pan (3).
5. Remove oil pan gasket from oil pan.
6. Remove magnet from oil pan.

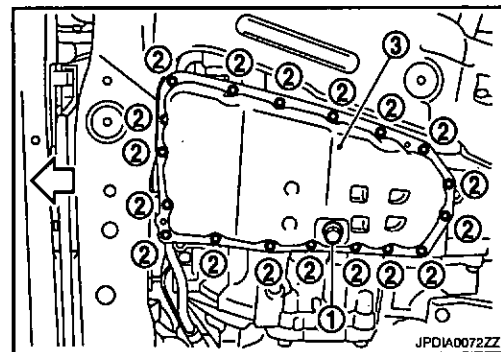

INSTALLATION

Note the following, and install in the reverse order of removal.

CAUTION:

- Completely remove all moisture, oil and old gasket, etc. from the oil pan gasket mounting surface of transaxle case and oil pan.
- Never reuse oil pan gasket, drain plug gasket and oil pan fitting bolts.

## OIL PAN

&lt; ON-VEHICLE REPAIR &gt;

[CVT: RE0F10A]

## Inspection

INFOID:000000004905313

Check foreign materials in oil pan to help determine causes of malfunction. If the CVT fluid is very dark, smells burned, or contains foreign particles, frictional material (clutches) may need replacement. A tacky film that will not wipe clean indicates varnish build up. Varnish can cause valves and clutches to stick and can inhibit pump pressure.

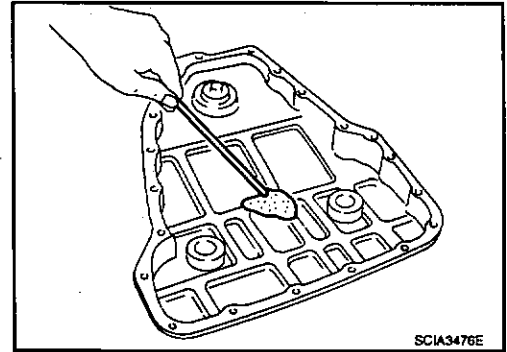

## INSPECTION AFTER INSTALLATION

Check for CVT fluid leakage and check CVT fluid level. Refer to TM-65, "Inspection".

# دیجیتال خودرو

شرکت دیجیتال خودرو سامانه (مسئولیت محدود)

اولین سامانه دیجیتال تعمیرکاران خودرو در ایران

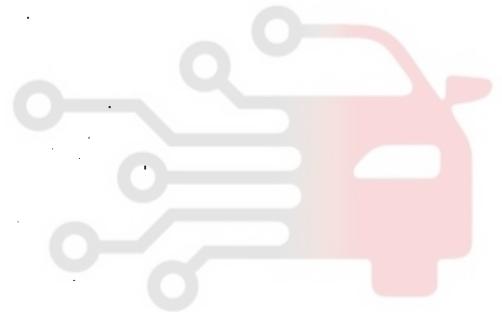



## PARK/NEUTRAL POSITION (PNP) SWITCH

## &lt; ON-VEHICLE REPAIR &gt;

[CVT: RE0F10A]

3. Loosen mounting bolts (A) of PNP switch. Insert a pin ( $\phi 4$  mm) into the adjusting holes (B) on both PNP switch and manual lever for adjusting the position.
4. Tighten mounting bolts of PNP switch.
5. Connect control cable on manual lever. Refer to TM-74, "Inspection and Adjustment".

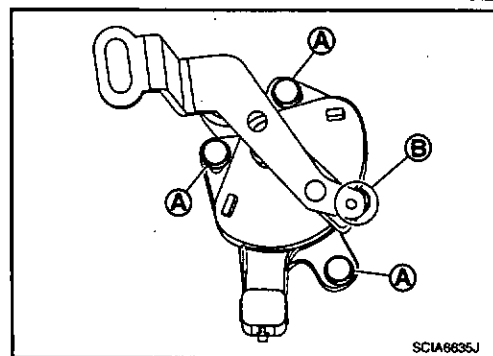

## ADJUSTMENT AFTER INSTALLATION

Adjust the CVT positions after installing the control device. Refer to TM-74, "Inspection and Adjustment".

## INSPECTION AFTER INSTALLATION

Check the CVT positions after adjusting the CVT positions. Refer to TM-74, "Inspection and Adjustment".

# دیجیتال خودرو

شرکت دیجیتال خودرو سامانه (مسئولیت محدود)

اولین سامانه دیجیتال تعمیرکاران خودرو در ایران





PRIMARY SPEED SENSOR

< ON-VEHICLE REPAIR >

[CVT: RE0F10A]

PRIMARY SPEED SENSOR

Exploded View

INFOID:000000004905317

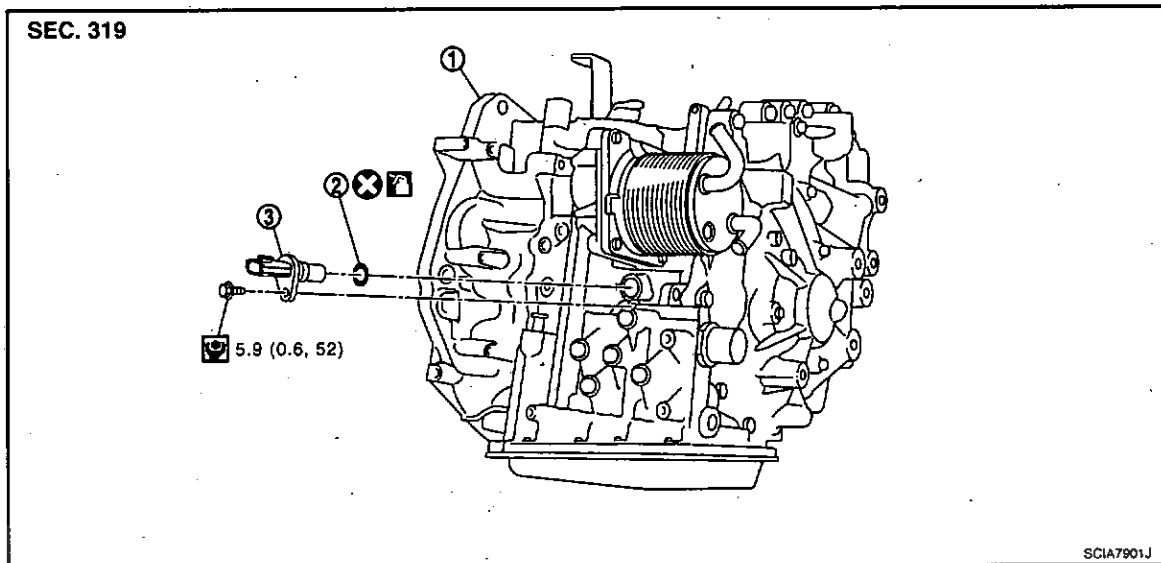

- 1. Transaxle assembly
- 2. O-ring
- 3. Primary speed sensor

: Apply CVT Fluid NS-2.

Refer to GI-3, "Components" for symbols not described above.

Removal and Installation

INFOID:000000004905318

REMOVAL

1. Remove primary speed sensor connector (A).
2. Remove primary speed sensor.
3. Remove O-ring from primary speed sensor.

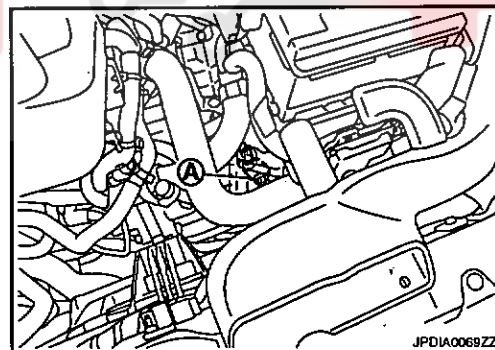

INSTALLATION

Note the following, and install in the reverse order of removal.

CAUTION:

- Never reuse O-ring.
- Apply CVT fluid to O-ring.

Inspection

INFOID:000000004905319

After completing installation, check for CVT fluid leakage and check CVT fluid level. Refer to TM-65, "Inspection".

## SECONDARY SPEED SENSOR

&lt; ON-VEHICLE REPAIR &gt;

[CVT: RE0F10A]

## SECONDARY SPEED SENSOR

Exploded View

INFOID:000000004905320

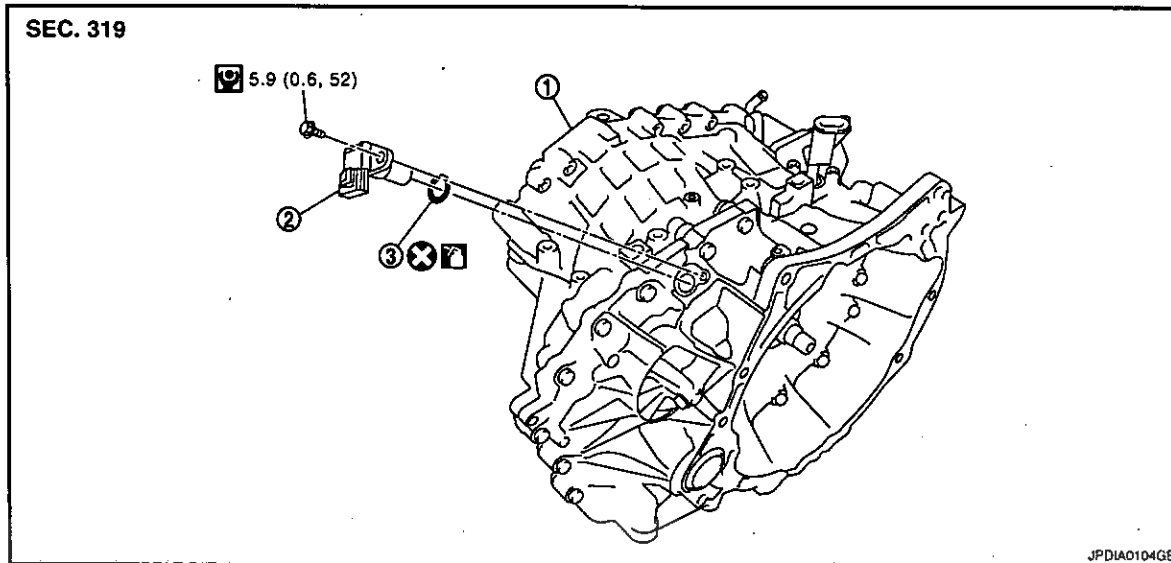

1. Transaxle assembly

2. Secondary speed sensor

3. O-ring

: Apply CVT Fluid NS-2.

Refer to [GI-3, "Components"](#) for symbols not described above.

## Removal and Installation

## REMOVAL

1. Remove secondary speed sensor connector.
2. Remove secondary speed sensor.
3. Remove O-ring from secondary speed sensor.

## INSTALLATION

Note the following, and install in the reverse order of removal.

**CAUTION:**

- **Never reuse O-ring.**
- **Apply CVT fluid to O-ring.**

## Inspection

INFOID:000000004905322

After completing installation, check for CVT fluid leakage and check CVT fluid level. Refer to [TM-65, "Inspection"](#).

DIFFERENTIAL SIDE OIL SEAL

< ON-VEHICLE REPAIR >

[CVT: RE0F10A]

DIFFERENTIAL SIDE OIL SEAL

2WD

2WD : Exploded View

INFOID:000000004905323

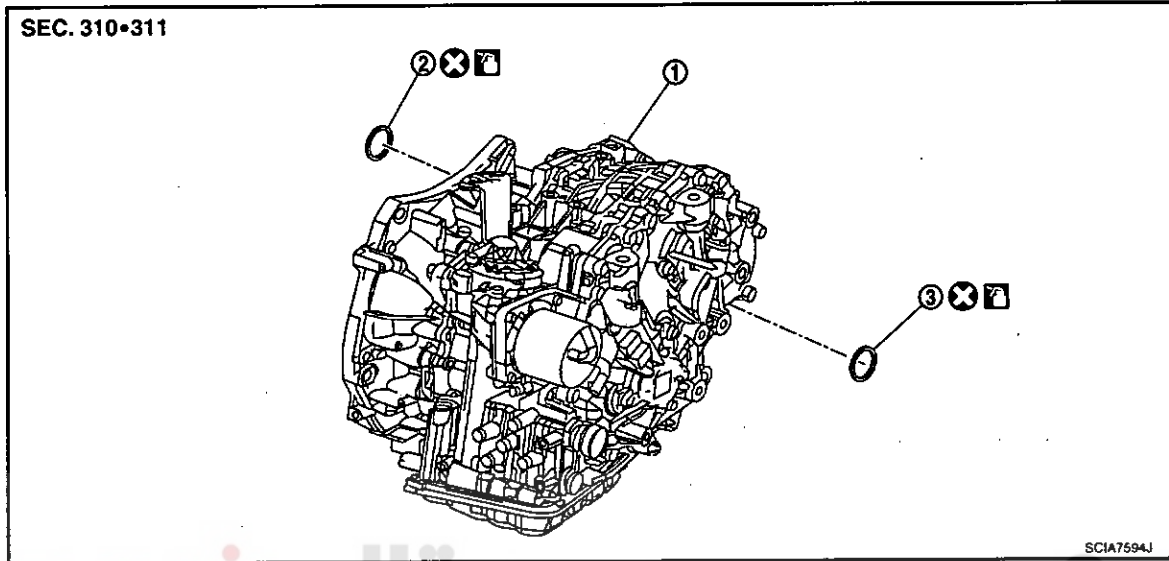

- 1. Transaxle assembly
- 2. RH differential side oil seal
- 3. LH differential side oil seal

: Apply CVT Fluid NS-2.

Refer to GI-3, "Components" for symbols not described above.

2WD : Removal and Installation

INFOID:000000004905324

REMOVAL

1. Remove drive shaft assembly. Refer to FAX-26, "MR20DE MODELS : Exploded View".
2. Remove differential side oil seals (1) using a flat-bladed screwdriver (A).

**CAUTION:**

Be careful not to scratch transaxle case and converter housing.

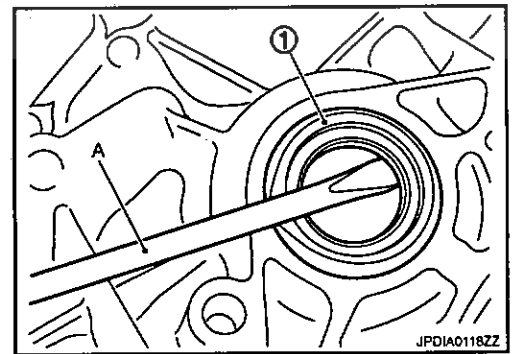

INSTALLATION

Note the following, and install in the reverse order of removal.

- Drive each differential side oil seal evenly using a commercial service tool so that differential side oil seal protrudes by the dimension (A) or (B) respectively.

Unit: mm (in)

Dimension A (transaxle case side)	1.8 ± 0.5 (0.071 ± 0.020)
Dimension B (converter housing side)	2.2 ± 0.5 (0.087 ± 0.020)

**NOTE:**

Differential side oil seal pulling direction is used as the reference.

**CAUTION:**

- Never reuse differential side oil seals.

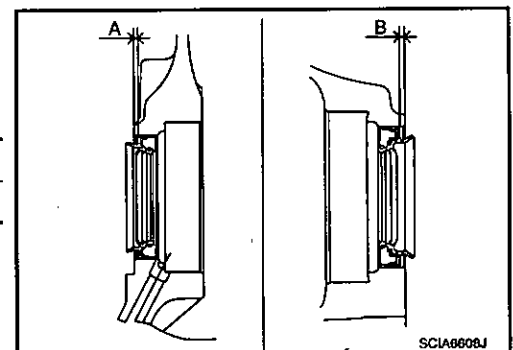

**DIFFERENTIAL SIDE OIL SEAL**

< ON-VEHICLE REPAIR >

[CVT: RE0F10A]

• Apply CVT fluid to differential side oil seals.

Drift to be used:

Location	Tool size
Transaxle case side	Commercial service tool [Outer diameter: 54 mm (2.13 in), inner diameter: 47 mm (1.85 in)]
Converter housing side	

**2WD : Inspection**

INFOID:000000004905326

After completing installation, check for CVT fluid leakage and check CVT fluid level. Refer to TM-65, "Inspection".

**4WD**

**4WD : Exploded View**

INFOID:000000004905326

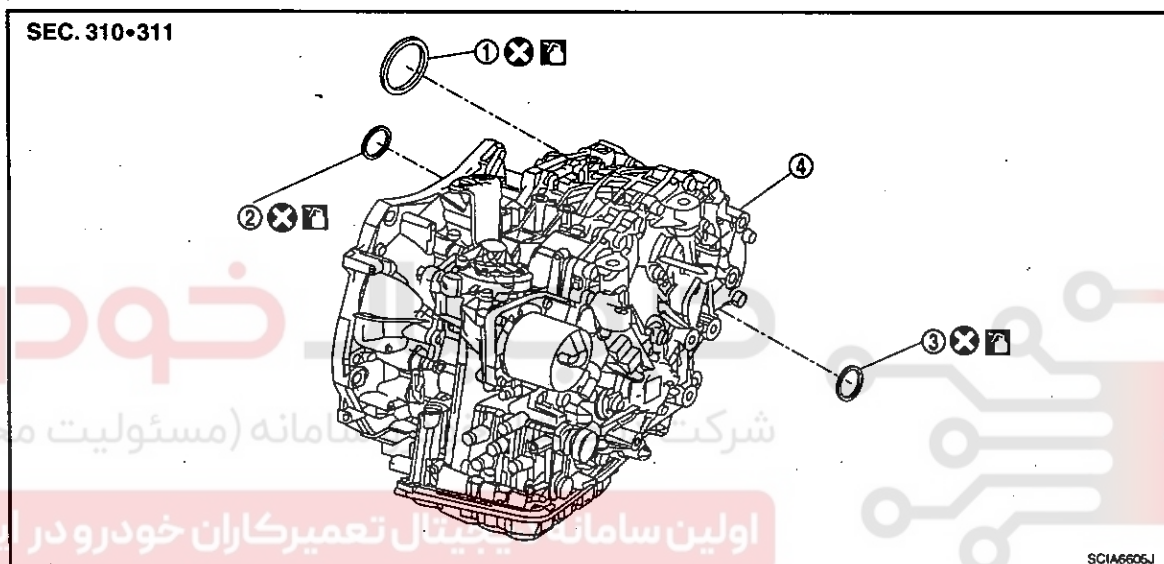

- 1. Side oil seal (transfer joint)
- 2. RH differential side oil seal
- 3. LH differential side oil seal
- 4. Transaxle assembly

: Apply CVT Fluid NS-2.

Refer to GI-3, "Components" for symbols not described above.

**4WD : Removal and Installation**

INFOID:000000004905327

**REMOVAL**

1. Remove exhaust front tube. Refer to EX-10, "Exploded View".
2. Separate the propeller shaft. Refer to DLN-105, "Exploded View".
3. Remove drive shaft assembly. Refer to FAX-60, "MR20DE MODELS : Exploded View".
4. Remove transfer from transaxle assembly. Refer to DLN-53, "MR20DE (CVT) : Exploded View".
5. Remove differential side oil seals (1) and side oil seal (transfer joint) using a flat-bladed screwdriver (A).

**CAUTION:**

Be careful not to scratch transaxle case and converter housing.

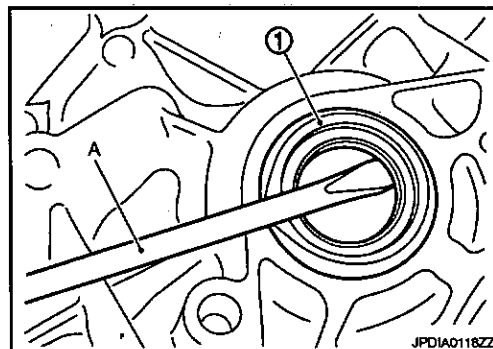

DIFFERENTIAL SIDE OIL SEAL

< ON-VEHICLE REPAIR >

[CVT: RE0F10A]

INSTALLATION

Note the following, and install in the reverse order of removal.

- Drive each differential side oil seal and side oil seal (transfer joint) evenly using a commercial service tool so that differential side oil seal and side oil seal (transfer joint) protrudes by the dimension (A), (B), or (C) respectively.

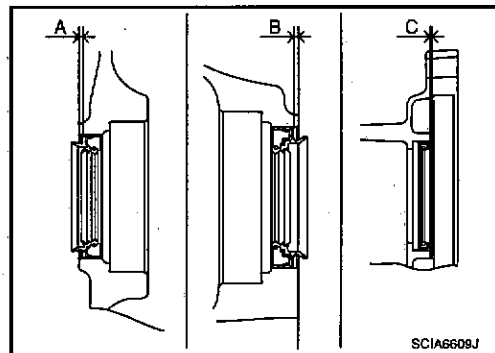

Unit: mm (in)

Dimension A (transaxle case side)	1.8 ± 0.5 (0.071 ± 0.020)
Dimension B (converter housing side)	2.2 ± 0.5 (0.087 ± 0.020)
Dimension C (transfer joint)	0.5 ± 0.5 (0.020 ± 0.020)

NOTE:

Differential side oil seal and side oil seal (transfer joint) pulling direction is used as the reference.

CAUTION:

- Never reuse differential side oil seals and side oil seal (transfer joint).
- Apply CVT fluid to differential side oil seals and side oil seal (transfer joint).

Drift to be used:

Location		Tool size
Differential side oil seal	Transaxle case side	Commercial service tool [Outer diameter: 54 mm (2.13 in), inner diameter: 47 mm (1.85 in)]
	Converter housing side	
Side oil seal (transfer joint)	Transaxle engagement	Commercial service tool [Outer diameter: 70 mm (2.76 in), inner diameter: 56 mm (2.20 in)]

4WD : Inspection

INFOID:000000004905328

After completing installation, check for CVT fluid leakage and check CVT fluid level. Refer to TM-65, "Inspection".

اولین سامانه دیجیتال تعمیرکاران خودرو در ایران

OIL PUMP FITTING BOLT

< ON-VEHICLE REPAIR >

[CVT: RE0F10A]

OIL PUMP FITTING BOLT

Description

INFOID:000000004905329

Replace the oil pump fitting bolt and the O-ring if oil leakage or exudes from the oil pump fitting bolt.

Exploded View

INFOID:000000004905330

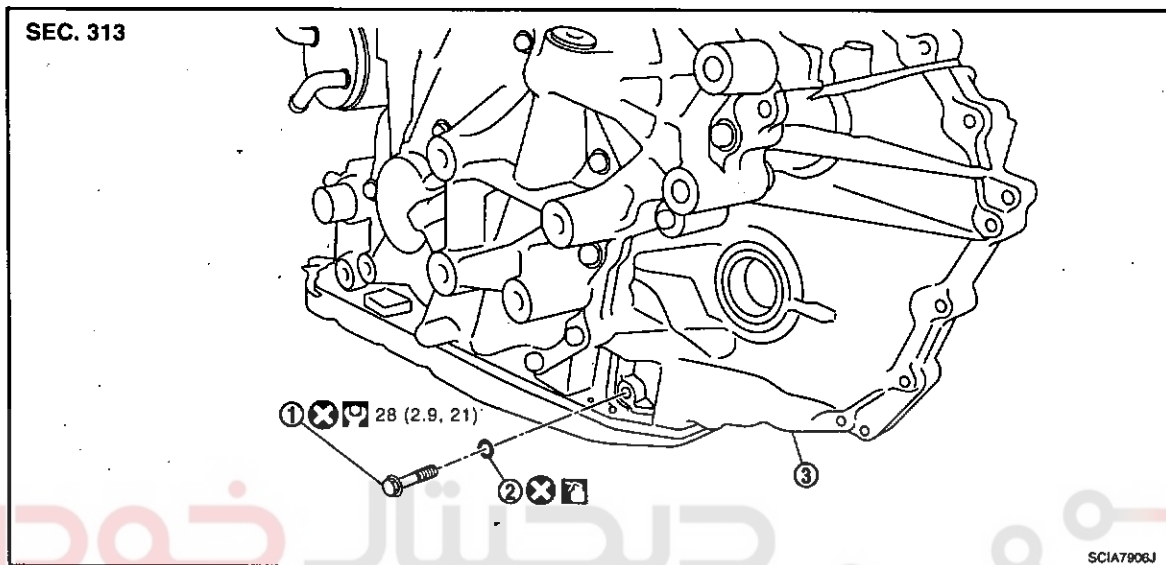

1. Oil pump fitting bolt

2. O-ring

3. Transaxle assembly

: Apply CVT Fluid NS-2.

Refer to GI-3, "Components" for symbols not described above.

Removal and Installation اولین سامانه دیجیتال تعمیر

INFOID:000000004905331

REMOVAL

1. Remove Oil pump fitting bolt (1) from transaxle assembly.
2. Remove O-ring from oil pump fitting bolt.

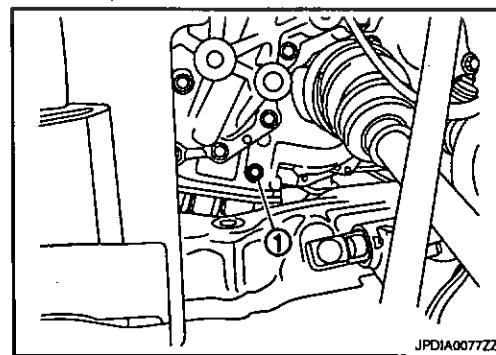

INSTALLATION

Note the following, and install in the reverse order of removal.

CAUTION:

- Never reuse oil pump fitting bolt and O-ring.
- Apply CVT fluid to O-ring.

Inspection

INFOID:000000004905332

After completing installation, check for CVT fluid leakage and check CVT fluid level. Refer to TM-65, "Inspection".

AIR BREATHER HOSE

< ON-VEHICLE REPAIR >

[CVT: RE0F10A]

AIR BREATHER HOSE

Exploded View

INFOID:000000004905333

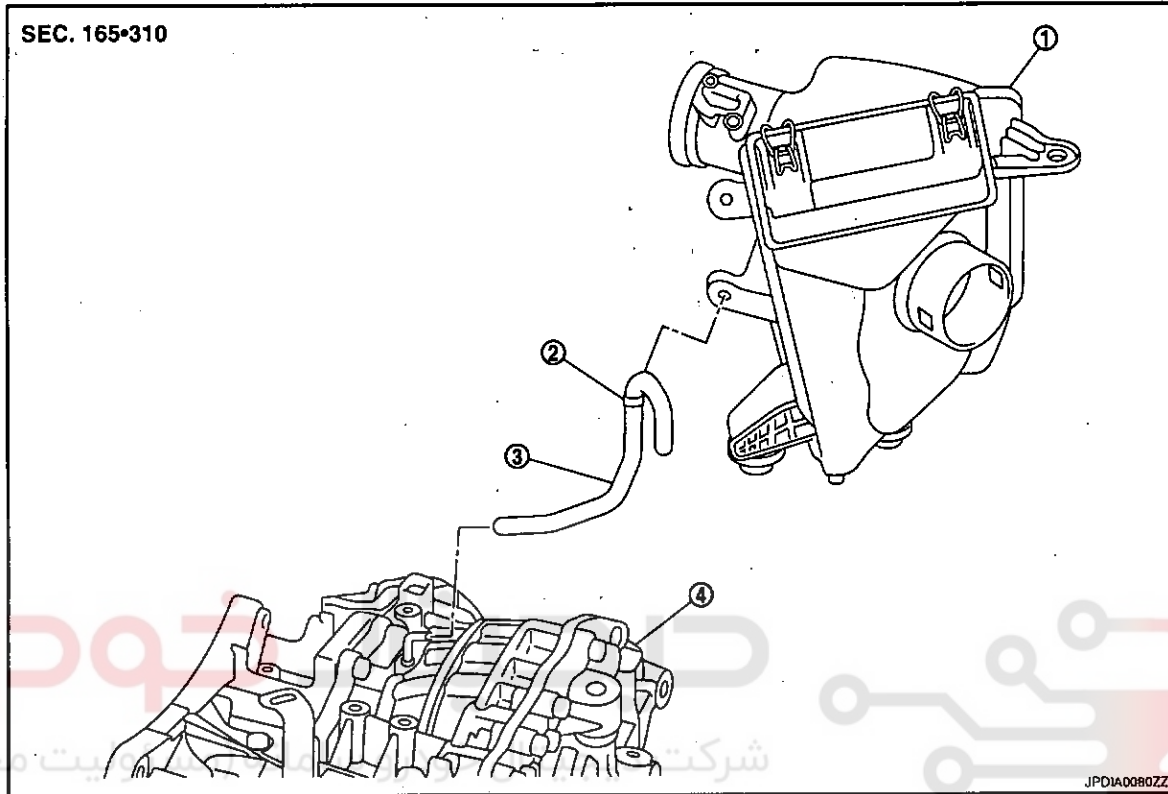

- 1. Air cleaner assembly
- 2. Clip
- 3. Air breather hose
- 4. Transaxle assembly

Removal and Installation

INFOID:000000004905334

REMOVAL

1. Remove clip from air cleaner assembly.
2. Remove air breather hose from transaxle assembly.

INSTALLATION

Note the following, and install in the reverse order of removal.

CAUTION:

**Check that air breather hose is not collapsed or blocked due to folding or bending when installed.**

- Install air breather hose to air breather tube so that the paint mark (A) faces upward. Also insert hose to the bend of air breather tube.

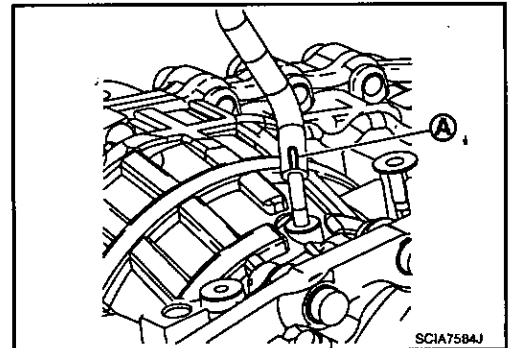

FLUID COOLER SYSTEM

WATER HOSE

WATER HOSE : Exploded View

INFOID:000000004905335

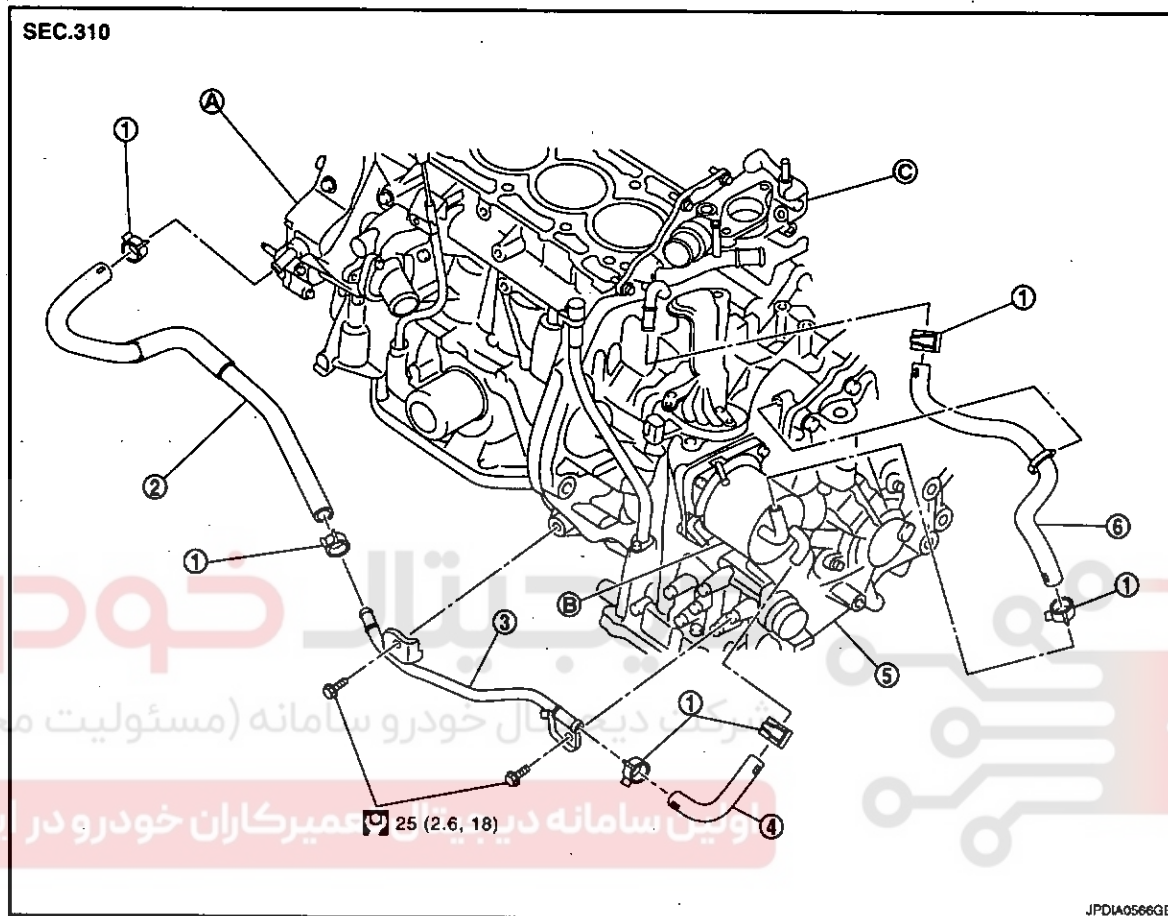

- |                     |                       |                     |
|---------------------|-----------------------|---------------------|
| 1. Hose clamp       | 2. CVT water hose A   | 3. CVT water tube   |
| 4. CVT water hose B | 5. Transaxle assembly | 6. CVT water hose C |
| A. Water pump       | B. CVT fluid cooler   | C. Water outlet     |

WATER HOSE : Removal and Installation

INFOID:000000004905336

REMOVAL

**WARNING:**

Never remove radiator cap when engine is hot. Serious burns may occur from high-pressure engine coolant escaping from radiator.

Wrap a thick cloth around the radiator cap. Slowly turn it a quarter of a turn to release built-up pressure. Then turn it all the way.

1. Remove the TCM. Refer to TM-75, "Exploded View".



FLUID COOLER SYSTEM

[CVT: RE0F10A]

< ON-VEHICLE REPAIR >

2. Remove TCM bracket (1). Refer to TM-75, "Exploded View".

← : Bolt

3. Remove hose clamps, and remove CVT water hose A.

4. Remove hose clamps, and remove CVT water hose B.

5. Remove hose clamps (1), and remove CVT water hose C (2).

← : Clip

6. Remove CVT water tube from transaxle assembly.

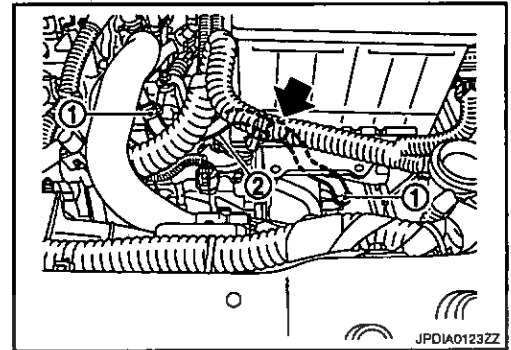
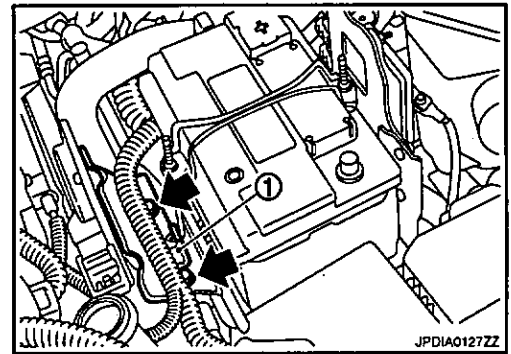

INSTALLATION

Note the following, and install in the reverse order of removal.

CVT water hose	Hose end	Paint mark	Position of hose clamp*
CVT water hose A	Water pump	Facing upward	B
	CVT water tube	Facing forward	E
CVT water hose B	CVT water tube	Facing forward	D
	CVT fluid cooler	Facing to the left of the vehicle	C
CVT water hose C	CVT fluid cooler	Facing forward	A
	Water outlet	Facing forward	A

\*: Refer to the illustrations for the specific position of each hose clamp tab.

• The illustrations indicate the view from the hose ends.

←F : Vehicle front

←G : Vehicle upper

• When installing hose clamps the center line of each clamp tab should be positioned as shown in the figure.

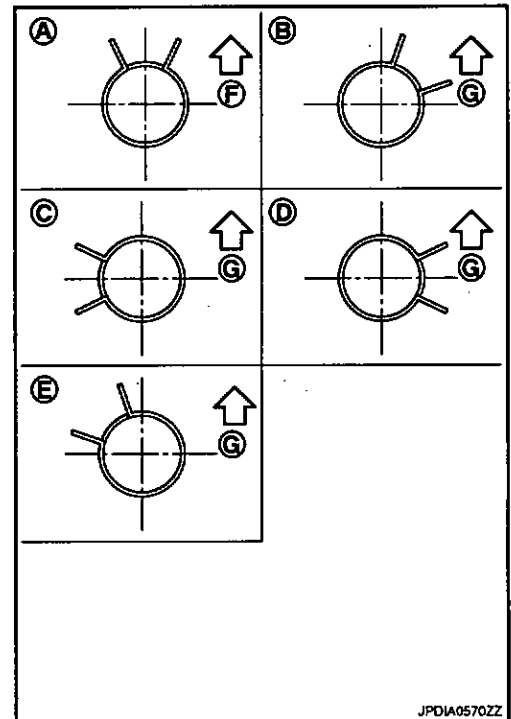

FLUID COOLER SYSTEM

< ON-VEHICLE REPAIR >

[CVT: RE0F10A]

- Insert CVT water hose according to dimension (A) described below.

(1)	(2)	Distance A
CVT water hose A	Water pump	27 mm (1.06 in)
	CVT water tube	
CVT water hose B	CVT water tube	End reaches the tube bend R position.
	CVT fluid cooler	
CVT water hose C	CVT fluid cooler	27 mm (1.06 in)
	Water outlet	

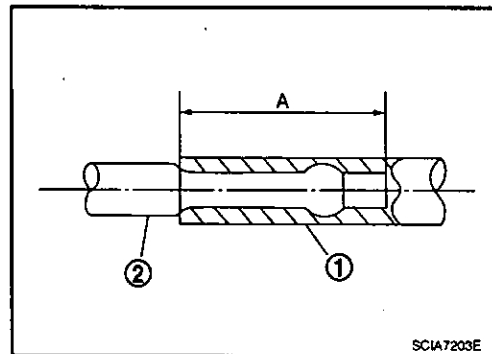

- Set hose clamps (1) from the end of fluid cooler hose (2) according to dimension (A) described below.

**Dimension A : 5 – 7 mm (0.20 – 0.28 in)**

- Hose clamp should not interfere with the bulge.

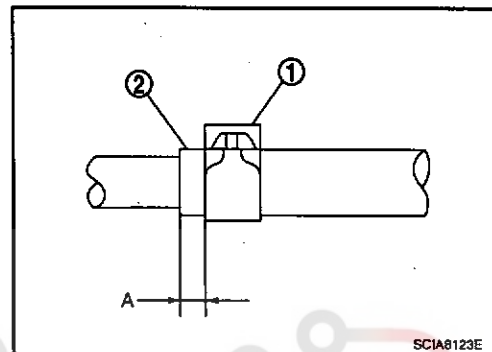

**WATER HOSE : Inspection**

After completing installation, check for engine coolant leakage and check engine coolant level. Refer to CO-30. "Inspection".

**FLUID COOLER (FOR AUSTRALIA AND MIDDLE EAST)**

اولین سامانه دیجیتال تعمیرکاران خودرو در ایران

FLUID COOLER SYSTEM

< ON-VEHICLE REPAIR >

[CVT: RE0F10A]

FLUID COOLER (FOR AUSTRALIA AND MIDDLE EAST) : Exploded view

INFOID:000000004905338

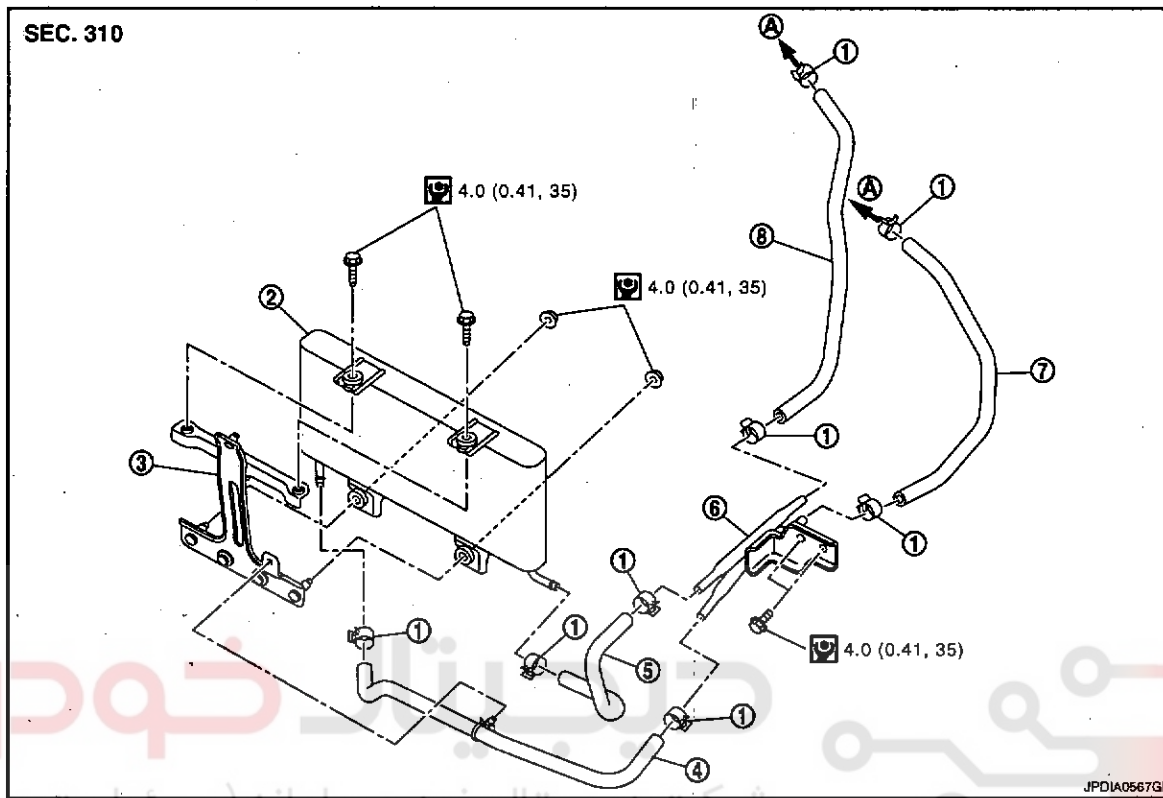

- |                        |                        |                      |
|------------------------|------------------------|----------------------|
| 1. Hose clamp          | 2. Fluid cooler        | 3. Bracket           |
| 4. Fluid cooler hose A | 5. Fluid cooler hose B | 6. Fluid cooler tube |
| 7. Fluid cooler hose D | 8. Fluid cooler hose C |                      |
- A. To CVT fluid cooler

Refer to GI-3 "Components" for symbols in the figure.

FLUID COOLER (FOR AUSTRALIA AND MIDDLE EAST) : Removal and Installation

INFOID:000000004905339

REMOVAL

1. Remove engine under cover with power tool.
2. Remove front bumper assembly. Refer to EXT-11 "Exploded View".
3. Remove air duct (inlet). Refer to EM-146 "Exploded View".

FLUID COOLER SYSTEM

< ON-VEHICLE REPAIR >

[CVT: RE0F10A]

4. Remove clip (A).

B : Bolt

C : Nut

↔ : Vehicle front

- 5. Remove hose clamps (1) and fluid cooler hose A (2).
- 6. Remove hose clamps (3) and fluid cooler hose B (4).
- 7. Remove fluid cooler (5).

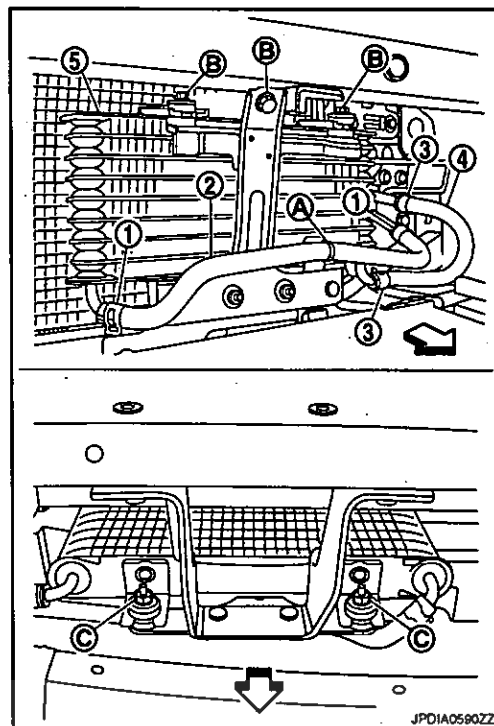

- 8. Remove hose clamps (1) and fluid cooler hose C (2).
- 9. Remove hose clamps (3) and fluid cooler hose D (4).
- 10. Remove fluid cooler tube (5).

← : Bolt

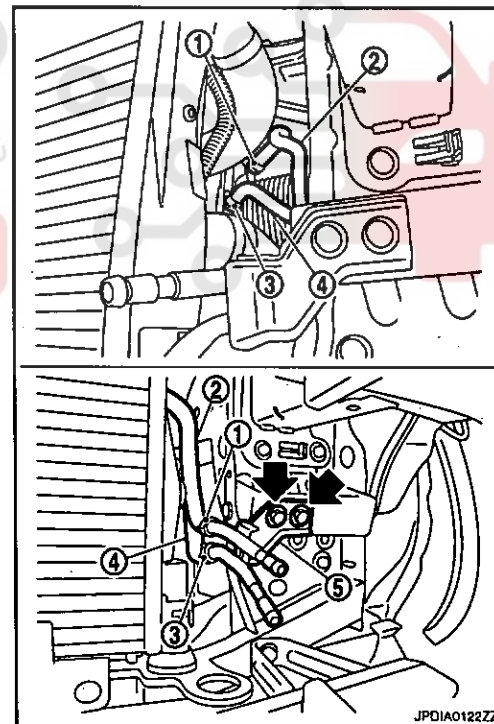

INSTALLATION

Note the following, and install in the reverse order of removal.

Fluid cooler hose	Hose end	Paint mark	Position of hose clamp*
Fluid cooler hose A	Fluid cooler side	Facing forward	D
	Fluid cooler tube side	Facing left of the vehicle	C
Fluid cooler hose B	Fluid cooler side	Facing forward	D
	Fluid cooler tube side	Facing left of the vehicle	C
Fluid cooler hose C	Fluid cooler tube side	Facing Right of the vehicle	C
	CVT fluid cooler side	Facing upward	B

FLUID COOLER SYSTEM

< ON-VEHICLE REPAIR >

[CVT: RE0F10A]

Fluid cooler hose	Hose end	Paint mark	Position of hose clamp*
Fluid cooler hose D	Fluid cooler tube side	Facing Right of the vehicle	C
	CVT fluid cooler side	Facing upward	A

\*: Refer to the illustrations for the specific position of each hose clamp tab.

• The illustrations indicate the view from the hose ends.

↔ : Vehicle upper

• When installing hose clamps the center line of each clamp tab should be positioned as shown in the figure.

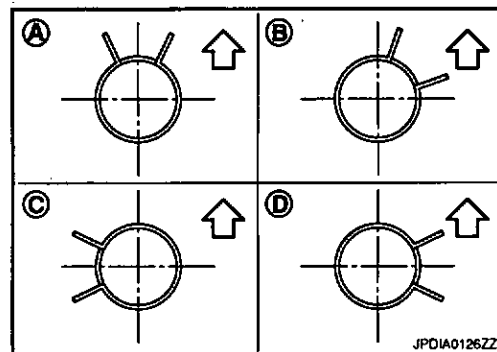

• Insert fluid cooler hose according to dimension (A) described below.

(1)	(2)	Distance A
Fluid cooler hose A, B	Fluid cooler	24 mm (0.94 in)
Fluid cooler hose A, B, C, D	Fluid cooler tube	33 mm (1.30 in)
Fluid cooler hose C, D	CVT fluid cooler	30 mm (1.18 in)

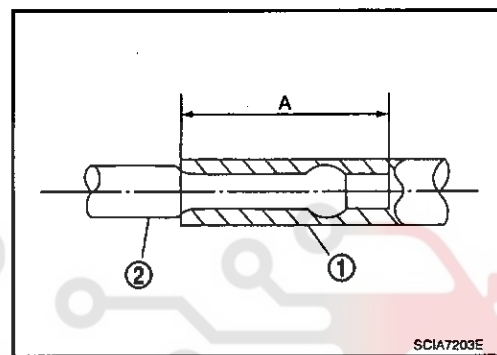

• Set hose clamps (1) from the end of fluid cooler hose (2) according to dimension (A) described below.

Dimension A : 5 – 7 mm (0.20 – 0.28 in)

• Hose clamp should not interfere with the bulge.

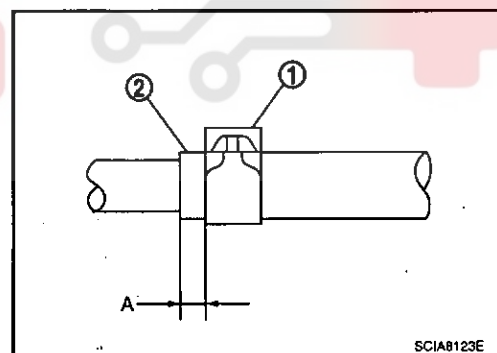

FLUID COOLER (FOR AUSTRALIA AND MIDDLE EAST) : Inspection

INFOID:000000004905340

After completing installation, check for CVT fluid leakage and check CVT fluid level. Refer to TM-65, "Inspection".

FLUID COOLER (EXCEPT FOR AUSTRALIA AND MIDDLE EAST)

FLUID COOLER SYSTEM

< ON-VEHICLE REPAIR >

[CVT: RE0F10A]

FLUID COOLER (EXCEPT FOR AUSTRALIA AND MIDDLE EAST) : Exploded view

INFOID:000000004905341

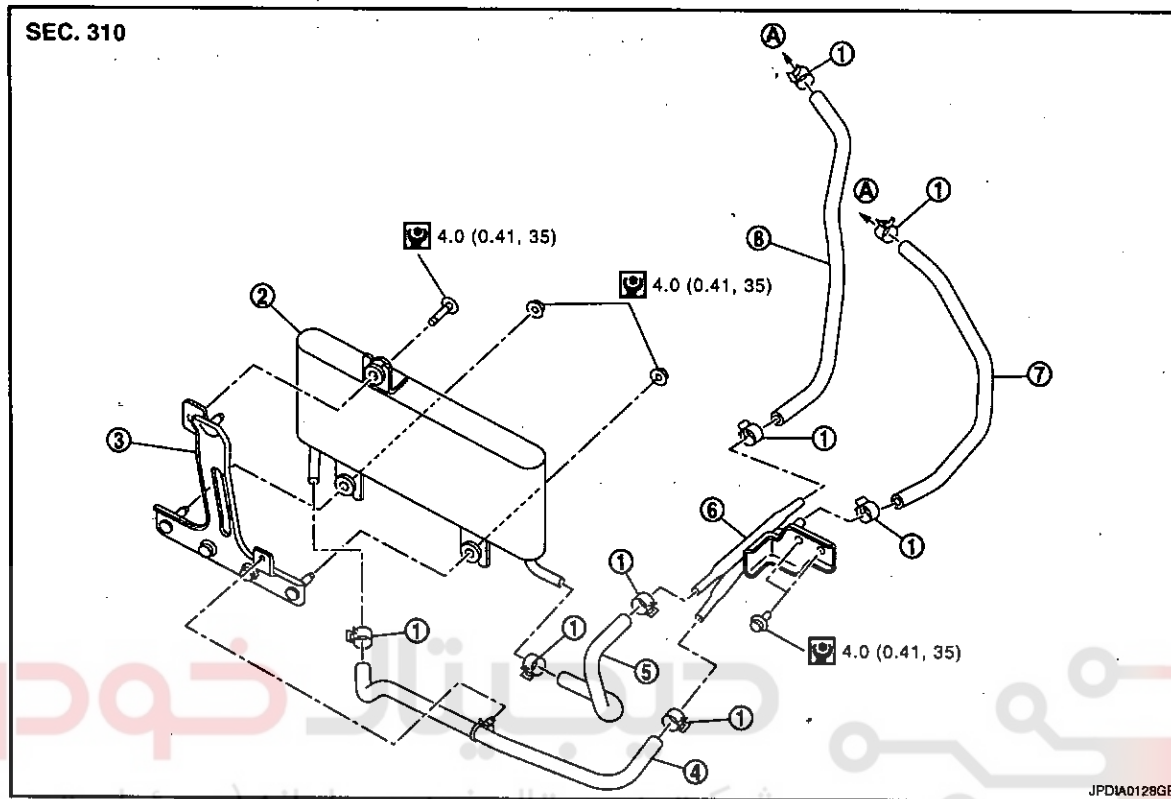

- |                        |                        |                      |
|------------------------|------------------------|----------------------|
| 1. Hose clamp          | 2. Fluid cooler        | 3. Bracket           |
| 4. Fluid cooler hose A | 5. Fluid cooler hose B | 6. Fluid cooler tube |
| 7. Fluid cooler hose D | 8. Fluid cooler hose C |                      |
- A. To CVT fluid cooler

Refer to GI-3, "Components" for symbols in the figure.

FLUID COOLER (EXCEPT FOR AUSTRALIA AND MIDDLE EAST) : Removal and Installation

INFOID:000000004905342

REMOVAL

1. Remove engine under cover.
2. Remove front bumper assembly. Refer to EXT-11, "Exploded View".
3. Remove air duct (inlet). Refer to EM-146, "Exploded View".

FLUID COOLER SYSTEM

[CVT: RE0F10A]

< ON-VEHICLE REPAIR >

4. Remove clip (A).

- B : Bolt
- C : Nut
- ↔ : Vehicle front

- 5. Remove hose clamp (1) and fluid cooler hose A (2).
- 6. Remove hose clamp (3) and fluid cooler hose B (4).
- 7. Remove fluid cooler (5).

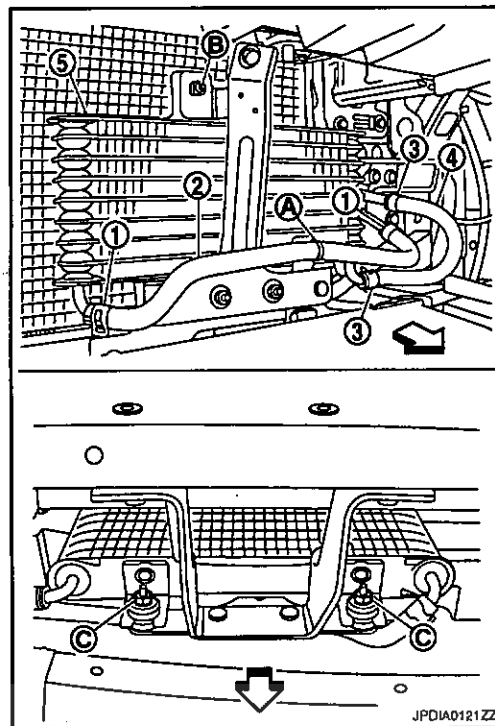

- 8. Remove hose clamp (1) and fluid cooler hose C (2).
- 9. Remove hose clamp (3) and fluid cooler hose D (4).
- 10. Remove fluid cooler tube (5).

← : Bolt

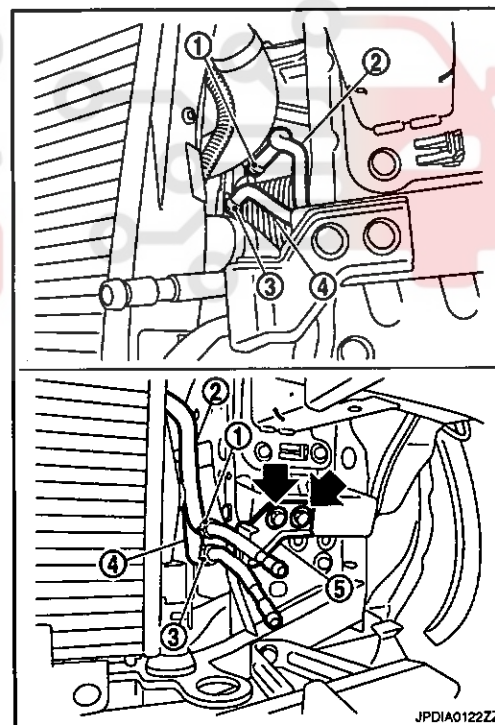

شرکت دیجیتال خودرو سامانه (مسئولیت محدود)

اولین سامانه دیجیتال تعمیرکاران خودرو در ایران

INSTALLATION

Note the following, and install in the reverse order of removal.

Fluid cooler hose	Hose end	Paint mark	Position of hose clamp*
Fluid cooler hose A	Fluid cooler side	Facing forward	D
	Fluid cooler tube side	Facing to the left of the vehicle	C
Fluid cooler hose B	Fluid cooler side	Facing forward	D
	Fluid cooler tube side	Facing to the left of the vehicle	C

FLUID COOLER SYSTEM

< ON-VEHICLE REPAIR >

[CVT: RE0F10A]

Fluid cooler hose	Hose end	Paint mark	Position of hose clamp*
Fluid cooler hose C	Fluid cooler tube side	Facing to the Right of the vehicle	C
	CVT fluid cooler side	Facing upward	B
Fluid cooler hose D	Fluid cooler tube side	Facing to the Right of the vehicle	C
	CVT fluid cooler side	Facing upward	A

\*: Refer to the illustrations for the specific position each hose clamp tab.

• The illustrations indicate the view from the hose ends.

↔ : Upper

• When installing hose clamps center line of each clamp tab should be positioned as shown in the figure.

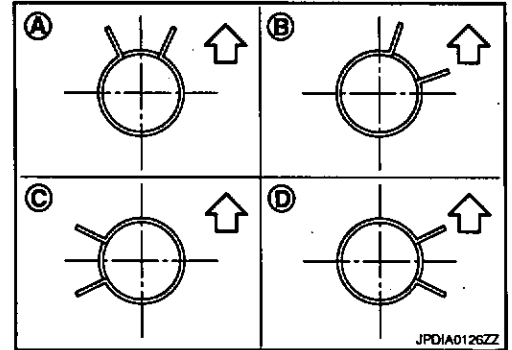

• Insert fluid cooler hose according to dimension (A) described below.

(1)	(2)	Distance A
Fluid cooler hose A, B	Fluid cooler	24 mm (0.94 in)
Fluid cooler hose A, B, C, D	Fluid cooler tube	33 mm (1.30 in)
Fluid cooler hose C, D	CVT fluid cooler	30 mm (1.18 in)

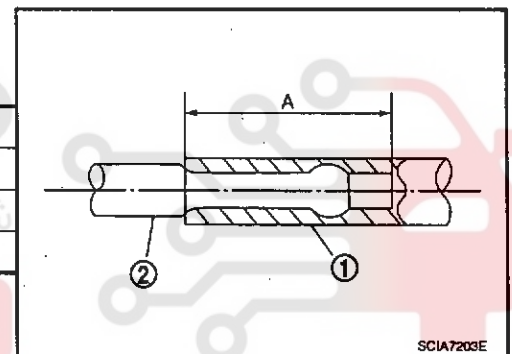

• Set hose clamps (1) from the end of fluid cooler hose (2) according to dimension (A) described below.

**Dimension A : 5 – 7 mm (0.20 – 0.28 in)**

• Hose clamp should not interfere with the bulge.

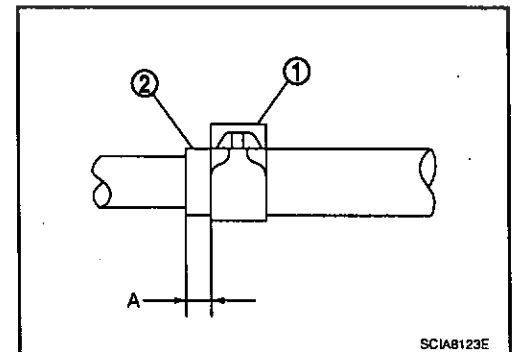

FLUID COOLER (EXCEPT FOR AUSTRALIA AND MIDDLE EAST) : Inspection

INFOID:000000004905343

After completing installation, check for CVT fluid leakage and check CVT fluid level. Refer to TM-65. "Inspection".



# REMOVAL AND INSTALLATION

## TRANSAXLE ASSEMBLY

2WD

2WD : Exploded View

INFOID:000000004905344

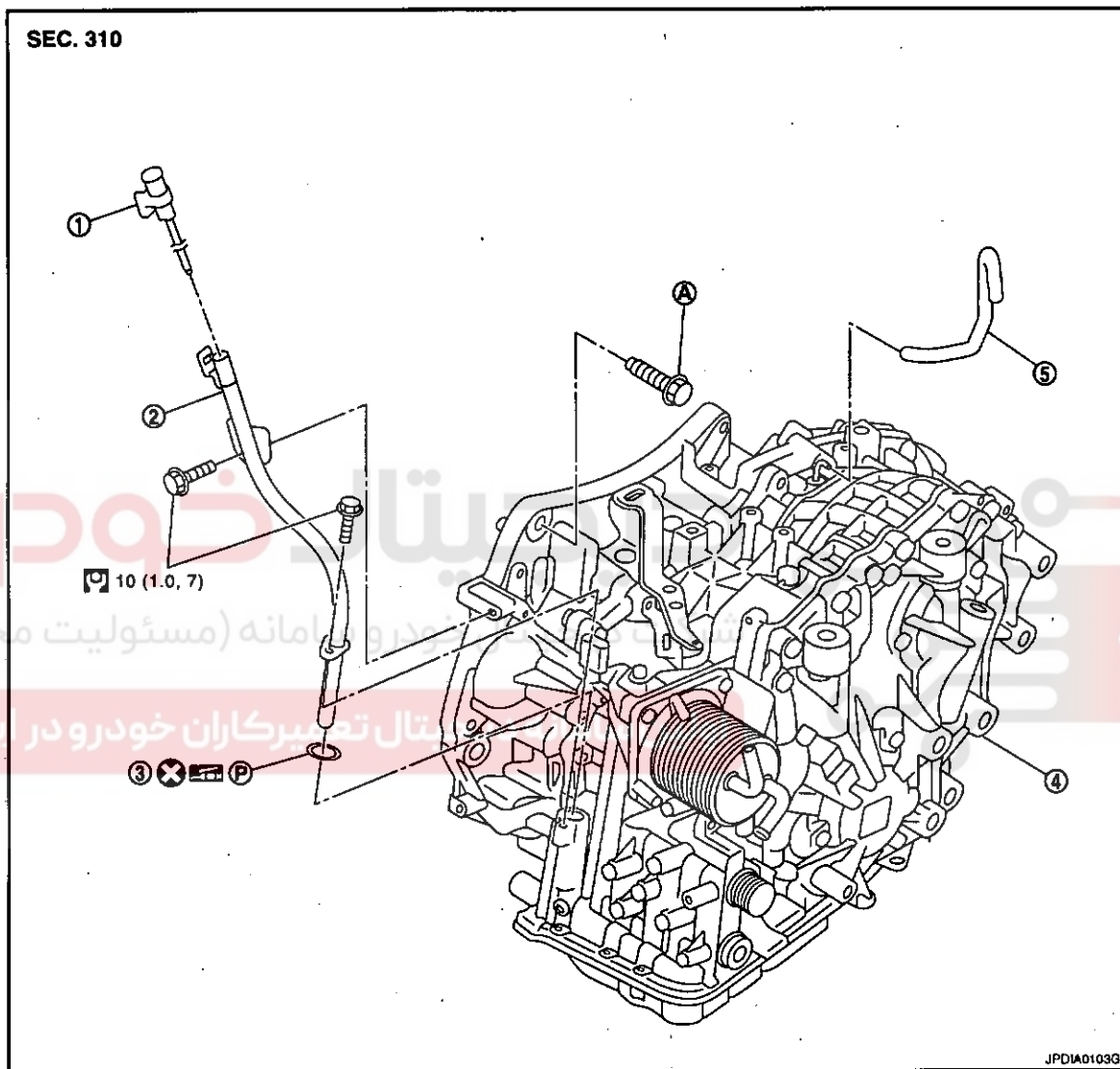

- |  |                            |           |
|--|----------------------------|-----------|
| 1. CVT fluid level gauge   | 2. CVT fluid charging pipe | 3. O-ring |
| 4. Transaxle assembly  | 5. Air breather hose       |           |
| A. For tightening torque, refer to <u>TM-105, "2WD : Removal and Installation"</u> . |                            |           |

Refer to GI-3, "Components" for symbols in the figure.

### 2WD : Removal and Installation

INFOID:000000004905345

#### WARNING:

Never remove the reservoir tank cap when the engine is hot. Serious burns could occur from high-pressure engine coolant escaping from the reservoir tank.

#### REMOVAL

1. Disconnect the battery cable from the negative terminal.
2. Remove air breather hose. Refer to TM-95, "Exploded View".

## TRANSAXLE ASSEMBLY

## &lt; REMOVAL AND INSTALLATION &gt;

[CVT: RE0F10A]

3. Remove air duct (inlet). Refer to EM-146, "Exploded View".
4. Remove battery. Refer to PG-89, "Exploded View".
5. Disconnect connectors (A) and then remove bracket (1).
6. Remove air cleaner case. Refer to EM-146, "Exploded View".
7. Drain engine coolant. Refer to CO-30, "Draining".
8. Remove CVT fluid level gauge.
9. Remove CVT fluid charging pipe from transaxle assembly.
10. Remove O-ring from CVT fluid charging pipe.

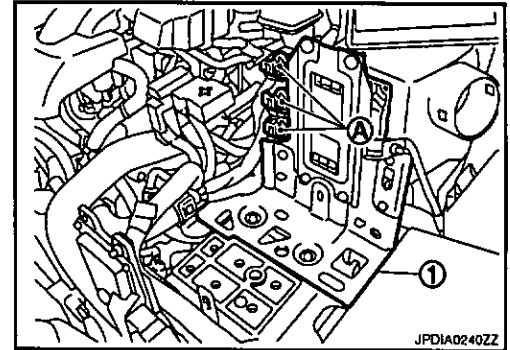

11. Disconnect fluid cooler hose from transaxle assembly. Refer to TM-99, "FLUID COOLER (FOR AUSTRALIA AND MIDDLE EAST) : Exploded view" (For Australia and Middle east), TM-102, "FLUID COOLER (EXCEPT FOR AUSTRALIA AND MIDDLE EAST) : Exploded view" (Except for Australia and Middle east).
12. Disconnect the following harness connectors and wire harnesses.
  - CVT unit harness connector (A).
  - Primary speed sensor harness connector (B).
  - Secondary speed sensor harness connector (C).
  - PNP switch connector (D).

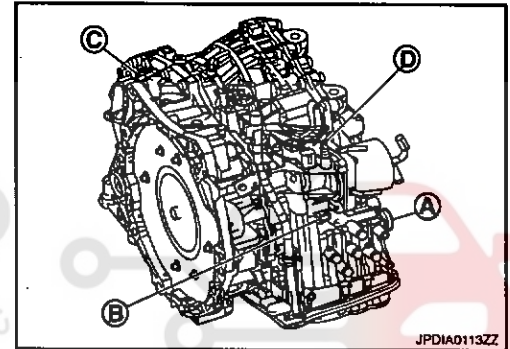

13. Remove harness and clip from the transaxle assembly.
14. Remove CVT water hose. Refer to TM-96, "WATER HOSE : Exploded View".
15. Remove control cable from transaxle assembly. Refer to TM-80, "Exploded View".
16. Remove starter motor. Refer to STR-18, "MR20DE MODELS : Exploded View".
17. Remove engine under cover with power tool.

18. Turn crankshaft, and remove the four tightening nuts (↔) for drive plate and torque converter.

**CAUTION:**

**When turning crankshaft, turn it clockwise as viewed from the front of the engine.**

19. Remove exhaust front tube. Refer to EX-10, "Exploded View".
20. Remove front drive shafts. Refer to FAX-26, "MR20DE MODELS : Exploded View".
21. Remove front suspension member from vehicle. Refer to FSU-18, "Exploded View".

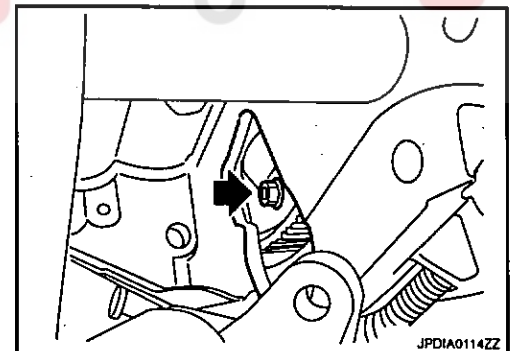

22. Support transaxle assembly with a transmission jack.

**CAUTION:**

**When setting the transmission jack, be careful not to collide against the drain plug.**

23. Support engine assembly with a transmission jack.

**CAUTION:**

**When setting the transmission jack, be careful not to collide against the drain plug.**

24. Remove engine mounting insulator (LH). Refer to EM-201, "CVT : Exploded View".
25. Remove bolts fixing transaxle assembly to engine assembly.
26. Remove transaxle assembly from vehicle.

**CAUTION:**

- Secure torque converter to prevent it from dropping.
- Secure transaxle assembly to a transmission jack.

27. Remove heater thermostat. Refer to CO-41, "Exploded View".

## INSTALLATION

TRANSAXLE ASSEMBLY

< REMOVAL AND INSTALLATION >

[CVT: RE0F10A]

Note following, and install in the reverse order of removal.

CAUTION:

- Check fitting of dowel pin (↔) when installing transaxle assembly to engine assembly.

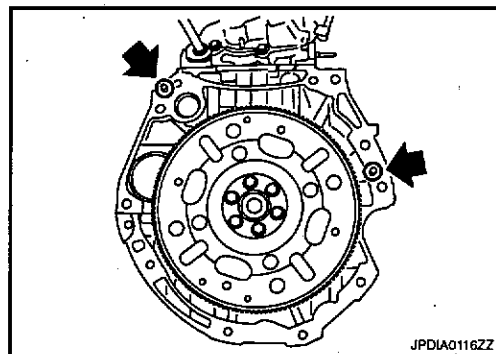

- When installing Transaxle assembly to the engine assembly, attach the fixing bolts in accordance with the following.

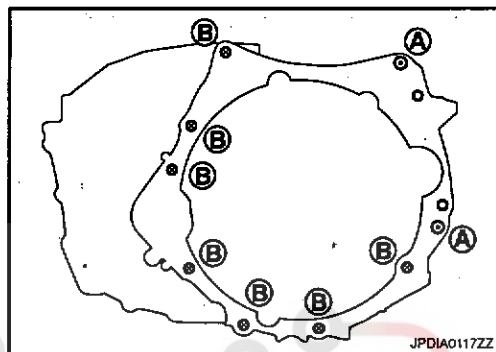

Bolt position	A	B
Insertion direction	Transaxle assembly to engine assembly	Engine assembly to transaxle assembly
Number of bolts	2	7
Bolt length mm (in)	55 (2.17)	50 (1.97)
Tightening torque N-m (kg-m, ft-lb)	62 (6.3, 46)	

- Set and screw in the drive plate location guide (commercial service tool: 31197CA000) (A) onto the stud bolts for the torque converter.

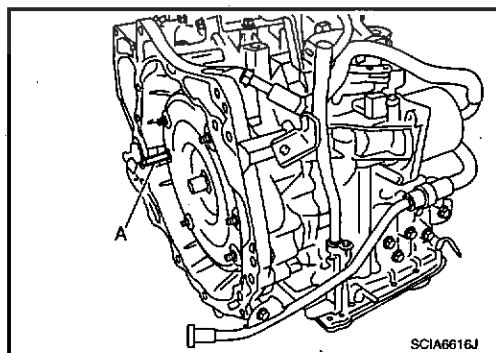

- When not using drive plate location guide, rotate torque converter so that the stud bolt (A) for mounting the drive plate location guide of torque converter aligns with the mounting position of starter motor.

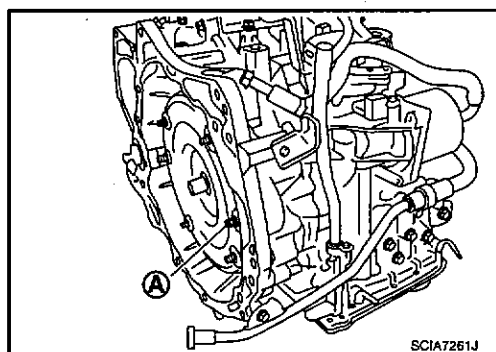

TRANSAXLE ASSEMBLY

< REMOVAL AND INSTALLATION >

[CVT: RE0F10A]

- Rotate crankshaft so that the hole (A) for inserting drive plate location guide of drive plate aligns with the mounting position (B) of starter motor.

**NOTE:**

When not using drive plate location guide, insert stud bolt of torque converter into the hole of drive plate, aligning the drive plate hole position and torque converter.

**CAUTION:**

Be careful not to strike the drive plate when installing the torque converter stud bolt.

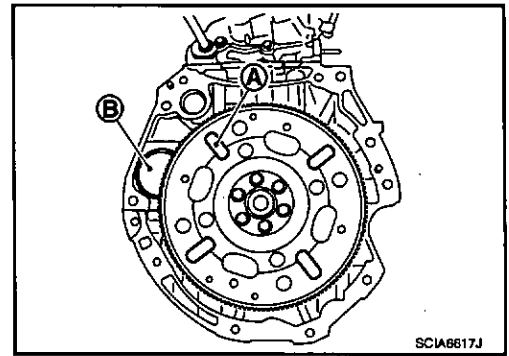

- Align the position of tightening nuts (←) for drive plate with those of the torque converter, and temporarily tighten the nuts. Then, tighten the bolts to the specified torque.

:51 N·m (5.2 kg-m, 38 ft-lb)

**CAUTION:**

- When turning crankshaft, turn it clockwise as viewed from the front of the engine.
- When tightening the tightening nuts for the torque converter after fixing the crankshaft pulley bolts, confirm the tightening torque of the crankshaft pulley mounting bolts. Refer to EM-165, "Removal and Installation".
- After converter is installed to drive plate, rotate crankshaft several turns and check that transaxle rotates freely without binding.
- Never reuse O-ring.
- Apply grease to O-ring.

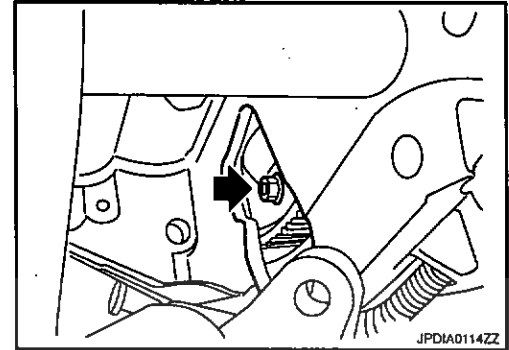

2WD : Inspection

INSPECTION BEFORE INSTALLATION

- After inserting a torque converter to transaxle assembly, check dimension (A) within the reference value limit.

- B : Scale
- C : Straightedge

Dimension A : Refer to TM-116, "Torque Converter".

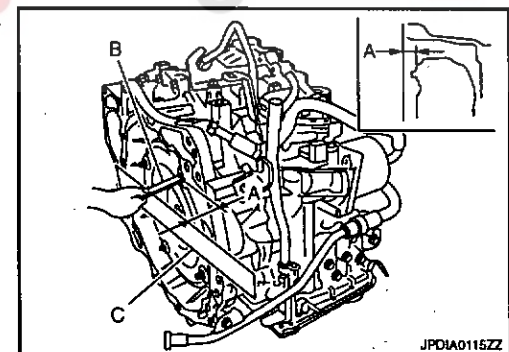

INSPECTION AFTER INSTALLATION

- After completing installation, check the following item.
  - CVT fluid leakage and CVT fluid level. Refer to TM-65, "Inspection".
  - CVT position. Refer to TM-74, "Inspection and Adjustment".

4WD

## TRANSAXLE ASSEMBLY

&lt; REMOVAL AND INSTALLATION &gt;

[CVT: RE0F10A]

4WD : Exploded View

INFOID:000000004905347

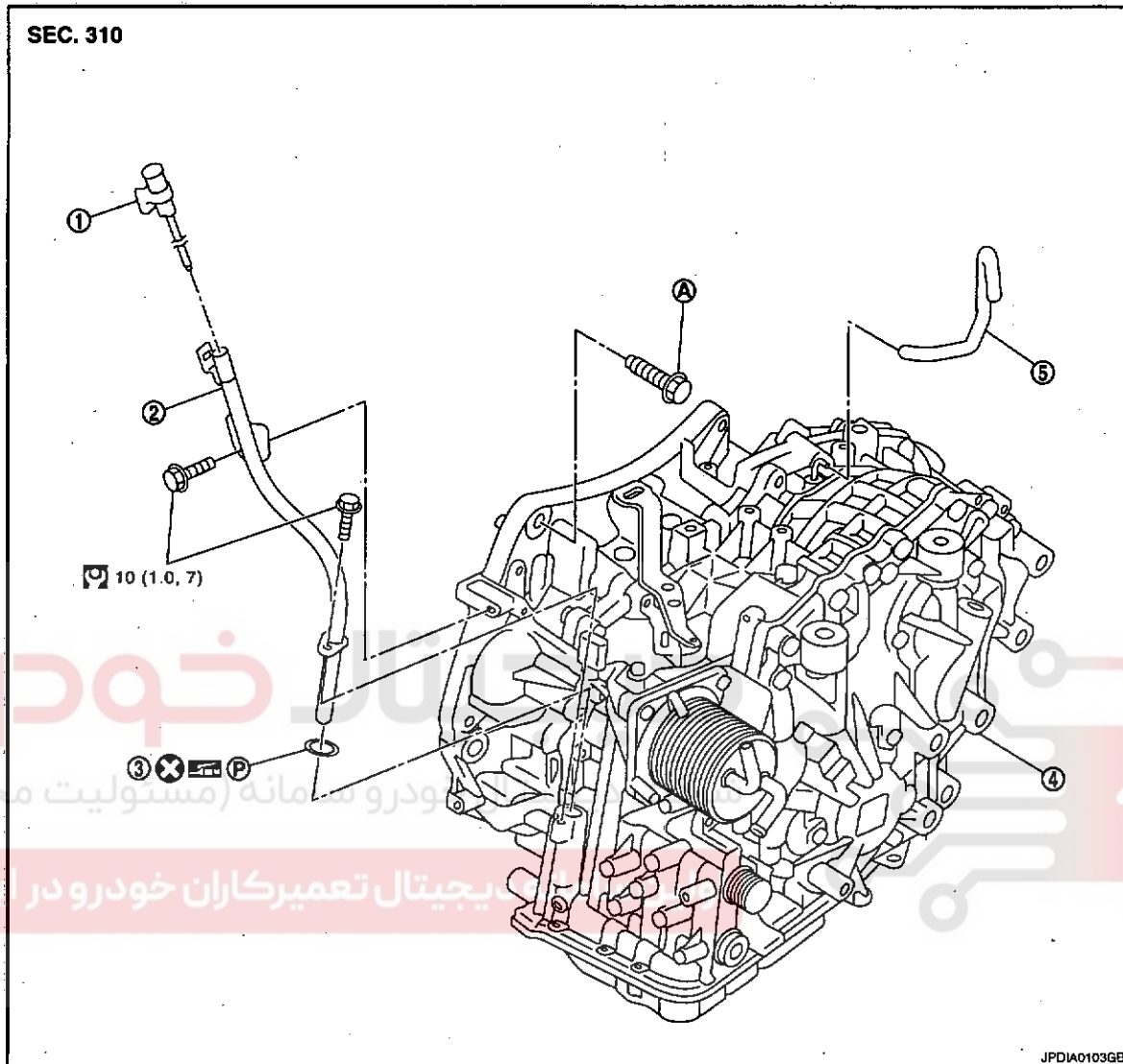

- |                          |                            |           |
|--------------------------|----------------------------|-----------|
| 1. CVT fluid level gauge | 2. CVT fluid charging pipe | 3. O-ring |
| 4. Transaxle assembly    | 5. Air breather hose       |           |

A. For tightening torque, refer to [TM-109](#), "4WD : Removal and Installation".

Refer to [GI-3](#), "Components" for symbols in the figure.

## 4WD : Removal and Installation

INFOID:000000004905348

**WARNING:**

Never remove the reservoir tank cap when the engine is hot. Serious burns could occur from high-pressure engine coolant escaping from the reservoir tank.

**REMOVAL**

1. Disconnect the battery cable from the negative terminal.
2. Remove air breather hose. Refer to [TM-95](#), "Exploded View".
3. Remove air duct (inlet). Refer to [EM-146](#), "Exploded View".
4. Remove battery. Refer to [PG-89](#), "Exploded View".

## TRANSAXLE ASSEMBLY

## &lt; REMOVAL AND INSTALLATION &gt;

[CVT: RE0F10A]

5. Disconnect connectors (A) and then remove bracket (1).
6. Remove air cleaner case. Refer to EM-146, "Exploded View".
7. Drain engine coolant. Refer to CO-30, "Draining".
8. Remove CVT fluid level gauge.
9. Remove CVT fluid charging pipe from transaxle assembly.
10. Remove O-ring from CVT fluid charging pipe.

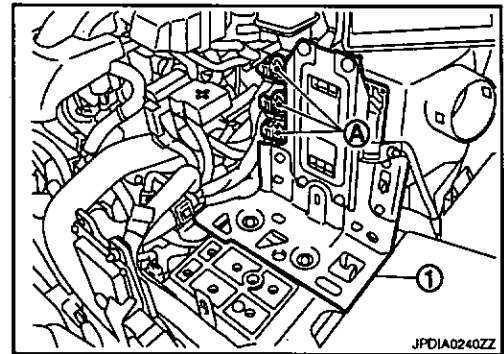

11. Disconnect fluid cooler hose from transaxle assembly. Refer to TM-99, "FLUID COOLER (FOR AUSTRALIA AND MIDDLE EAST) : Exploded view" (For Australia and Middle east), TM-102, "FLUID COOLER (EXCEPT FOR AUSTRALIA AND MIDDLE EAST) : Exploded view" (Except for Australia and Middle east).
12. Disconnect the following harness connectors and wire harnesses.
  - CVT unit harness connector (A).
  - Primary speed sensor harness connector (B).
  - Secondary speed sensor harness connector (C).
  - PNP switch connector (D).
13. Remove harness and clip from the transaxle assembly.
14. Remove CVT water hose. Refer to TM-96, "WATER HOSE : Exploded View".
15. Remove control cable from transaxle assembly. Refer to TM-80, "Exploded View".

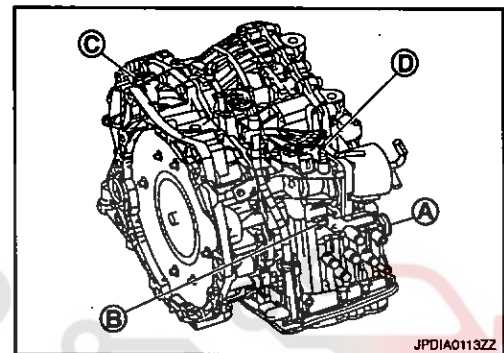

16. Remove starter motor. Refer to STR-18, "MR20DE MODELS : Exploded View".
17. Remove engine under cover with power tool.
18. Turn crankshaft, and remove the four tightening nuts (↔) for drive plate and torque converter.
 

**CAUTION:**  
When turning crankshaft, turn it clockwise as viewed from the front of the engine.

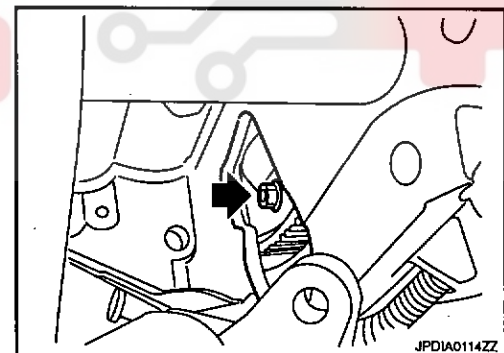

19. Remove exhaust front tube. Refer to EX-10, "Exploded View".
20. Separate the propeller shaft. Refer to DLN-105, "Exploded View".
21. Remove front drive shafts. Refer to FAX-26, "MR20DE MODELS : Exploded View".
22. Remove front suspension member from vehicle. Refer to FSU-18, "Exploded View".
23. Remove transfer assembly from transaxle assembly with power tool. Refer to DLN-53, "MR20DE (CVT) : Exploded View".
24. Support transaxle assembly with a transmission jack.
 

**CAUTION:**  
When setting the transmission jack, be careful not to collide against the drain plug.
25. Support engine assembly with a transmission jack.
 

**CAUTION:**  
When setting the transmission jack, be careful not to collide against the drain plug.
26. Remove engine mounting insulator (LH). Refer to EM-201, "CVT : Exploded View".
27. Remove bolts fixing transaxle assembly to engine assembly.
28. Remove transaxle assembly from vehicle.
 

**CAUTION:**

  - Secure torque converter to prevent it from dropping.
  - Secure transaxle assembly to a transmission jack.
29. Remove heater thermostat. Refer to CO-41, "Exploded View".

TRANSAXLE ASSEMBLY

< REMOVAL AND INSTALLATION >

[CVT: RE0F10A]

INSTALLATION

Note following, and install in the reverse order of removal.

CAUTION:

- Check fitting of dowel pin (↔) when installing transaxle assembly to engine assembly.

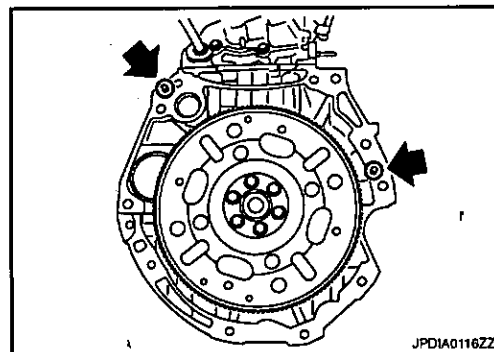

- When installing transaxle assembly to the engine assembly, attach the fixing bolts in accordance with the following.

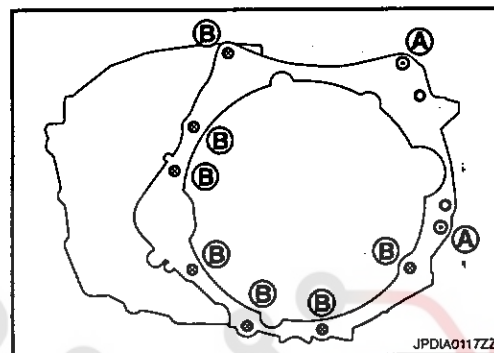

Bolt position	A	B
Insertion direction	Transaxle assembly to engine assembly	Engine assembly to transaxle assembly
Number of bolts	2	7
Bolt length mm (in)	55 (2.17)	50 (1.97)
Tightening torque N-m (kg-m, ft-lb)	62 (6.3, 46)	

- Set and screw in the drive plate location guide (commercial service tool: 31197CA000) (A) onto the stud bolts for the torque converter.

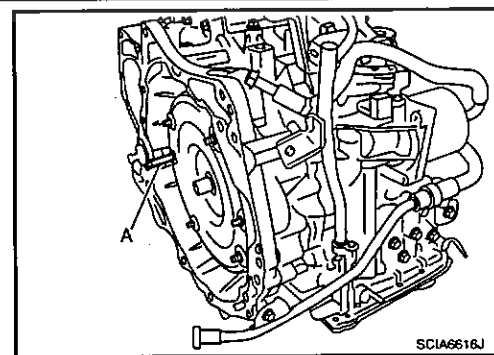

- When not using drive plate location guide, rotate torque converter so that the stud bolt (A) for mounting the drive plate location guide of torque converter aligns with the mounting position of starter motor.

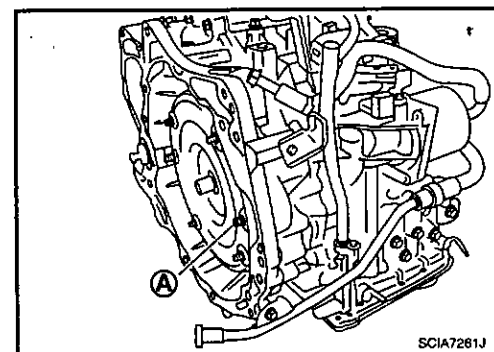

## TRANSAXLE ASSEMBLY

## &lt; REMOVAL AND INSTALLATION &gt;

[CVT: RE0F10A]

- Rotate crankshaft so that the hole (A) for inserting drive plate location guide of drive plate aligns with the mounting position (B) of starter motor.

**NOTE:**

When not using drive plate location guide, insert stud bolt of torque converter into the hole of drive plate, aligning the drive plate hole position and torque converter.

**CAUTION:**

Be careful not to strike the drive plate when installing the torque converter stud bolt.

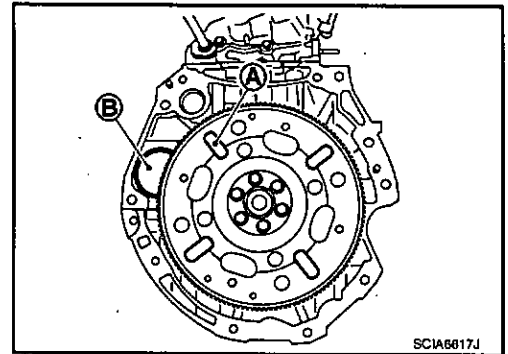

- Align the position of tightening nuts (←) for drive plate with those of the torque converter, and temporarily tighten the nuts. Then, tighten the bolts to the specified torque.

 :51 N·m (5.2 kg-m, 38 ft-lb)

**CAUTION:**

- When turning crankshaft, turn it clockwise as viewed from the front of the engine.
- When tightening the tightening nuts for the torque converter after fixing the crankshaft pulley bolts, confirm the tightening torque of the crankshaft pulley mounting bolts. Refer to EM-165. "Removal and Installation".
- After converter is installed to drive plate, rotate crankshaft several turns and check that transaxle rotates freely without binding.
- Never reuse O-ring.
- Apply grease to O-ring.

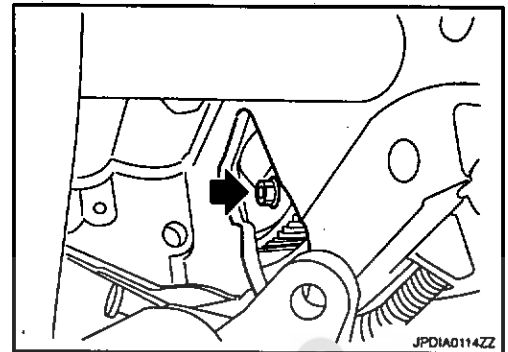

## 4WD : Inspection

## INSPECTION BEFORE INSTALLATION

- After inserting a torque converter to transaxle assembly, check dimension (A) within the reference value limit.

B : Scale

C : Straightedge

Dimension A : Refer to TM-116. "Torque Converter".

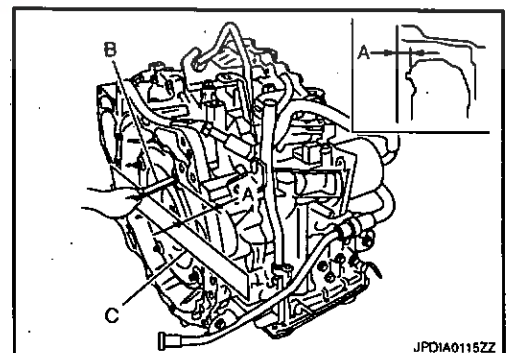

## INSPECTION AFTER INSTALLATION

- After completing installation, check the following item.
  - CVT fluid leakage and CVT fluid level. Refer to TM-65. "Inspection".
  - CVT position. Refer to TM-74. "Inspection and Adjustment".



DISASSEMBLY AND ASSEMBLY

TORQUE CONVERTER AND CONVERTER HOUSING OIL SEAL

Exploded View

INFOID:000000004905350

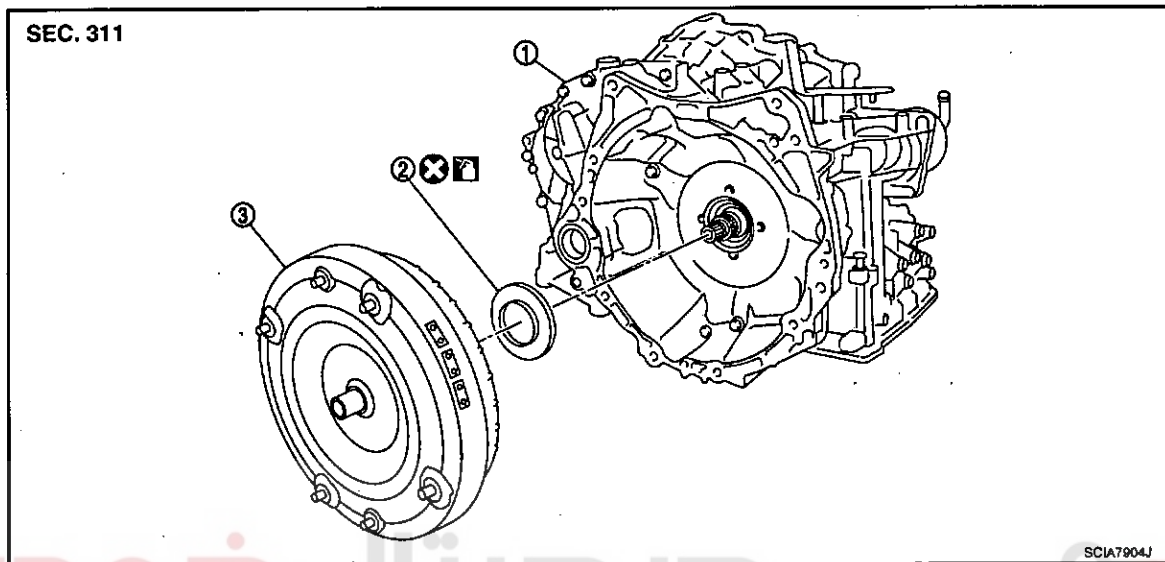

- 1. Transaxle assembly
- 2. Converter housing oil seal
- 3. Torque converter

: Apply CVT Fluid NS-2.

Refer to GI-3, "Components" for symbols not described on the above.

Disassembly

INFOID:000000004905351

1. Remove transaxle assembly. Refer to TM-105, "2WD : Exploded View" (2WD), TM-109, "4WD : Exploded View" (4WD).
2. Remove torque converter from transaxle assembly.  
**CAUTION:**  
Never damage bushing inside of torque converter sleeve when removing torque converter.
3. Remove converter housing oil seal using a flat-bladed screwdriver.  
**CAUTION:**  
Be careful not to scratch converter housing.

Assembly

INFOID:000000004905352

Note the following, and install in the reverse order of removal.

- Drive converter housing oil seal (1) evenly using a drift (A) (commercial service tool) so that converter housing oil seal protrudes by the dimension (B) respectively.

Unit: mm (in)	
Commercial service tool: A	Outer diameter: 65 (2.56)
	Inner diameter: 60 (2.36)

2 : Transaxle assembly

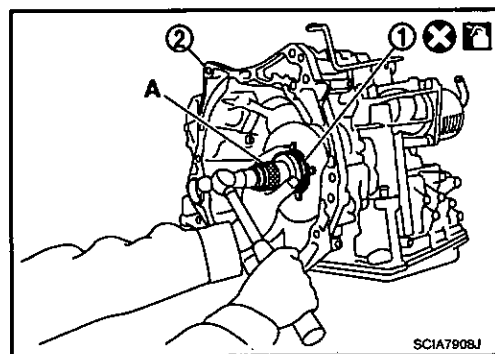

**TORQUE CONVERTER AND CONVERTER HOUSING OIL SEAL**

< DISASSEMBLY AND ASSEMBLY >

[CVT: RE0F10A]

Dimension B	1.0 ± 0.5 (0.039 ± 0.020)
-------------	---------------------------

Unit: mm (in)

**NOTE:**

Converter housing oil seal pulling direction is used as the reference.

- After completing installation, check for CVT fluid leakage and CVT fluid level. Refer to TM-65, "Inspection".

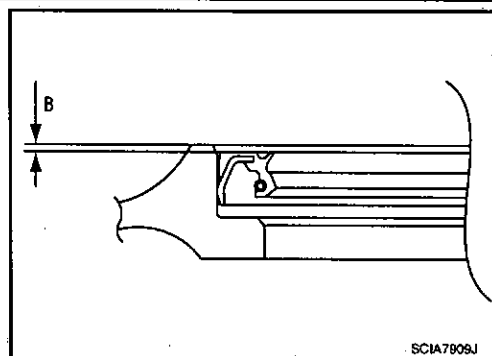

SCIA7909J

- Attach the pawl (A) of the torque converter to the drive sprocket hole (B) on the transaxle assembly side.

**CAUTION:**

- Rotate the torque converter for installing torque converter.
- Never damage the bushing inside the torque converter sleeve when installing the converter housing oil seal.
- Never reuse converter housing oil seal.
- Apply CVT fluid to converter housing oil seal.

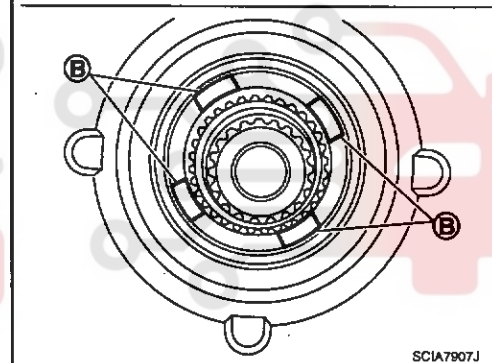
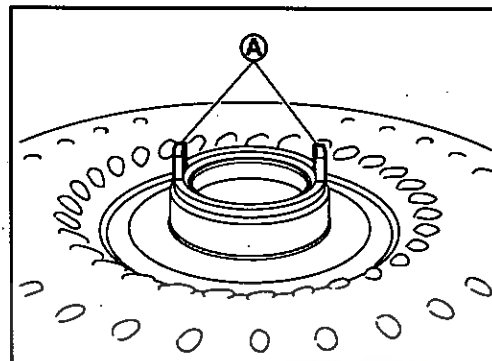

SCIA7907J

INFOID:000000004905353

**Inspection**

**INSPECTION AFTER INSTALLATION**

- After inserting a torque converter to transaxle assembly, check dimension (A) within the reference value limit.

- B : Scale
- C : Straightedge

**Dimension A** : Refer to TM-116, "Torque Converter".

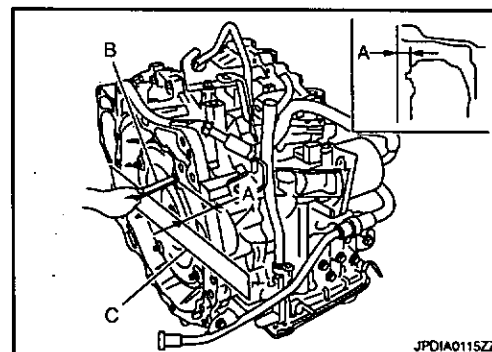

JPDIA0115ZZ

SERVICE DATA AND SPECIFICATIONS (SDS)

< SERVICE DATA AND SPECIFICATIONS (SDS)

[CVT: RE0F10A]

SERVICE DATA AND SPECIFICATIONS (SDS)

SERVICE DATA AND SPECIFICATIONS (SDS)

General Specification

INFOID:000000004905354

Applied model		MR20DE	
		2WD	4WD
CVT model		RE0F10A	
CVT assembly	Model code number	1XF2B	1XF2D
Transmission gear ratio	D range	2.349 – 0.394	
	Reverse	1.750	
	Final drive	6.466	
Recommended fluid		NISSAN CVT Fluid NS-2*	
Fluid capacity		7.6 liter (6-5/8 Imp qt) <sup>*2</sup>	8.5 liter (7-1/2 Imp qt) <sup>*2</sup>

CAUTION:

- Use only Genuine NISSAN CVT Fluid NS-2. Never mix with other fluid.
- Using CVT fluid other than Genuine NISSAN CVT Fluid NS-2 will deteriorate in driveability and CVT durability, and may damage the CVT, which is not covered by the warranty.

\*1: Refer to MA-13: "Fluids and Lubricants".

\*2: The fluid capacity is the reference value. Check the fluid level with CVT fluid level gauge.

Vehicle Speed When Shifting Gears

INFOID:000000004905355

Numerical value data are reference values.

Throttle position	Shift pattern	Engine speed (rpm)	
		At 40 km/h (25 MPH)	At 60 km/h (37 MPH)
8/8	"D" position	3,600 – 4,500	4,500 – 5,400
2/8	"D" position	1,200 – 3,100	1,300 – 3,500

CAUTION:

Lock-up clutch is engaged when vehicle speed is approximately 18 km/h (11 MPH) to 90 km/h (56 MPH).

Stall Speed

INFOID:000000004905356

Stall speed	2,500 – 3,000 rpm
-------------	-------------------

Line Pressure

INFOID:000000004905357

Engine speed	Line pressure (kPa (bar, kg/cm <sup>2</sup> , psi))
	"R" and "D" positions
At idle	750 (7.50, 7.65, 108.8)
At stall	5,700 (57.00, 58.14, 826.5)*

\*: Reference values

## SERVICE DATA AND SPECIFICATIONS (SDS)

&lt; SERVICE DATA AND SPECIFICATIONS (SDS)

[CVT: RE0F10A]

## Solenoid Valves

INFOID:000000004905358

Name	Resistance (Approx.)	Terminal
Pressure control solenoid valve B (secondary pressure solenoid valve)	3.0 – 9.0 Ω	3
Pressure control solenoid valve A (line pressure solenoid valve)		2
Torque converter clutch solenoid valve		12
Lock-up select solenoid valve	17.0 – 38.0 Ω	13

## CVT Fluid Temperature Sensor

INFOID:000000004905359

Name	Condition	Voltage (Approx.)	Resistance (Approx.)
CVT fluid temperature sensor	20°C (68°F)	2.0 V	6.5 kΩ
	80°C (176°F)	1.0 V	0.9 kΩ

## Primary Speed Sensor

INFOID:000000004905360

Name	Condition	Data (Approx.)
Primary speed sensor	When driving ["M1" position, 20 km/h (12 MPH)]	800 Hz

## Secondary Speed Sensor

INFOID:000000004905361

Name	Condition	Data (Approx.)
Secondary speed sensor	When driving ["D" position, 20 km/h (12 MPH)]	500 Hz

## Torque Converter

INFOID:000000004905362

Dimension between end of converter housing and torque converter	14.4 mm (0.567 in)
---	--------------------