

ENGINE ELECTRIC DEVICES**1452-01/1462-01/2610-01/1440-01****INDEX****ENGINE ELECTRIC DEVICES****GENERAL**

1. DIAGNOSTIC INFORMATION AND PROCEDURE.....	3
---	---

**OVERVIEW AND OPERATION
PROCESS**

1. DESCRIPTION AND OPERATION.....	5
-----------------------------------	---

REMOVAL AND INSTALLATION

1452-01 GENERATOR REPAIR INSTRUCTIONS.....	11
1462-01 STARTER REPAIR INSTRUCTIONS.....	12
2610-01 BATTERY REPAIR INSTRUCTIONS.....	13
1440-01 SPARK PLUG AND IGNITION COIL REPAIR INSTRUCTIONS....	14



دیجیتال خودرو

شرکت دیجیتال خودرو سامانه (مسئولیت محدود)

اولین سامانه دیجیتال تعمیرکاران خودرو در ایران



Modification basis	
Application basis	
Affected VIN	

ENGINE ELECTRIC DEVICES**0000-00****GENERAL****1. DIAGNOSTIC INFORMATION AND PROCEDURE****1) Ignition System**

Condition	Probable Cause	Correction
No Crank	• Low battery voltage.	• Charging the battery or Replace the battery.
	• Battery cable is loose, corroded, or damaged.	• Repair or Replace the battery cable.
	• Faulty starter motor or starter motor circuit is open.	• Repair or Replace the starter motor/starter motor circuit.
	• Faulty ignition switch.	• Replace the ignition switch.
	• Ground short.	• Repair the ground short.
Crank OK, But Too Slow	• Low battery voltage.	• Charging the battery or Replace the battery.
	• Battery.	• Repair or Replace the battery cable.
	• Battery cables are loose, corroded, or damaged.	• Repair or Replace the starter motor.
Starter Motor Does Not Stop	• Faulty starter motor.	• Repair or Replace the starter motor.
	• Faulty ignition switch.	• Replace the ignition switch.
Starter Motor Running, But Not Cranking	• Broken the clutch pinion gear or faulty starter motor.	• Replace the starter motor.
	• Broken the flywheel ring gear.	• Replace the flywheel.
	• Connected circuit is open.	• Repair the open circuit.
Battery Discharge	• Loosen the generator drive belt.	• Adjust the belt tension or Replace the belt.
	• The circuit is open or a short.	• Repair the open or a short circuit.
	• Battery run down.	• Replace the battery.
	• Open ground circuit.	• Repair the open ground circuit.
Charging Indicator Lamp Does Not Work When the Ignition Switch ON (Engine Does Not Work)	• Charging indicator lamp is blown or fuse is blown.	• Repair or Replace the charging indicator lamp/fuse.
	• Faulty ignition switch.	• Replace the ignition switch.
	• Generator ground circuit is open or a short.	• Repair the circuit.
Charging Indicator Lamp Does Not Put Out Lights After Starting the Engine	• Battery cable is corroded or damaged.	• Repair or Replace the battery cable.
	• Loosen the generator drive belt.	• Adjust the belt tension or Replace the belt.
	• Faulty wiring harness.	• Repair the wiring harness.
Battery Over Charging	• Generator Voltage Regulator Faulty	• Replace Generator
	• Voltage detecting wiring faulty	• Repair Wiring

Modification basis	
Application basis	
Affected VIN	

2) Ignition System (Cont'd)

Condition	Probable Cause	Correction
Hard Engine Starting	• Ignition coil faulty	• Replace ignition coil
	• Distributor (including optical sensor) faulty	• Replace distributor (or sensor)
	• Spark plug malfunction	• Replace spark plug or adjust clearance
	• Ignition timing faulty (spark plug light is normal)	• Resetting valve timing
Unstable Engine Idling	• Spark plug malfunction	• Replace spark plug or adjust clearance
	• Ignition coil faulty	• Replace ignition coil
	• Ignition timing faulty	• Resetting valve timing
Enging Acceralation Malfunction	• Ignition timing faulty	• Resetting valve timing

دیجیتال خودرو

شرکت دیجیتال خودرو سامانه (مسئولیت محدود)

اولین سامانه دیجیتال تعمیرکاران خودرو در ایران



OVERVIEW AND OPERATION PROCESS

1. DESCRIPTION AND OPERATION

1) Battery

The sealed battery is standard on all cars. There are no vent plugs in the cover.

The battery is completely sealed, except for two small vent holes in the sides.

These vent holes allow the small amount of gas produced in the battery to escape.

The battery has the following advantages over conventional batteries:

- No water addition for the life of the battery.
- Overcharge protection. If too much voltage is applied to the battery, it will not accept as much current as a conventional battery.
In a conventional battery, the excess voltage will still try to charge the battery, leading to gassing, which causes liquid loss.
- Not as liable to self-discharge as a conventional battery. This is particularly important when a battery is left standing for long periods of time.
- More power available in a lighter, smaller case.

The battery has three major functions in the electrical system.

First, the battery provides a source of energy for cranking the engine.

Second, the battery acts as a voltage stabilizer for the electrical system. Finally, the battery can, for a limited time, provide energy when the electrical demand exceeds the output of the generator.

2) Ratings

- ▶ A battery has two ratings: (1) a reserve capacity rating designated at 27°C(80°F), which is the time a fully charged battery will provide 25 amperes of current flow at or above 10.5 volts (2) a cold cranking amp rating determined under testing at -18°C(0°F), which indicates the cranking load capacity.

(1) Reserve Capacity

The reserve capacity (RC) is the maximum length of time it is possible to travel at night with the minimum electrical load and no generator output. Expressed in minutes, the RC rating is the time required for a fully charged battery, at a temperature of 27°C(80°F) and being discharged at a current of 25 amperes, to reach a terminal voltage of 10.5 volts.

Modification basis	
Application basis	
Affected VIN	

(2) Cold Cranking Amperage

The cold cranking amperage test is expressed at a battery temperature of $-18^{\circ}\text{C}(0^{\circ}\text{F})$.

The current rating is the minimum amperage, which must be maintained by the battery for 30 seconds at the specified temperature, while meeting a minimum voltage requirement of 7.2 volts.

This rating is a measure of cold cranking capacity.

The battery is not designed to last indefinitely. However, with proper care, the battery will provide many years of service. If the battery tests well, but fails to perform satisfactorily in service for no apparent reason, the following factors may point to the cause of the trouble:

- Vehicle accessories are left on overnight.
- Slow average driving speeds are used for short periods.
- The vehicle's electrical load is more than the generator output, particularly with the addition of aftermarket equipment.
- Defects in the charging system, such as electrical shorts, a slipping generator belt, a faulty generator, or a faulty voltage regulator.
- Battery abuse, including failure to keep the battery cable terminals clean and tight or a loose battery hold-down clamp.
- Mechanical problems in the electrical system, such as shorted or pinched wires.

3) Charging Time Required

The time required to charge a battery will vary depending upon the following factors:

- ▶ **Size of Battery** - A Completely discharged large heavy-duty battery required more than twice the recharging time as a completely discharged small passenger car battery.
- ▶ **Temperature** - A longer time will be needed to charge any battery at $-18^{\circ}\text{C}(0^{\circ}\text{F})$ than at $27^{\circ}\text{C}(80^{\circ}\text{F})$.
When a fast charger is connected to a cold battery, the current accepted by the battery will be very low at first.
The battery will accept a higher current rate as the battery warms.
- ▶ **Charger Capacity** - A charger which can supply only 5 amperes will require a much longer charging period than a charger that can supply 30 amperes or more.
- ▶ **State-of-Charge** - A completely discharged battery requires more than twice as much charge as a onehalf charged battery.
Because the electrolyte is nearly pure water and a poor conductor in a completely discharged battery, the current accepted by the battery is very low at first. Later, as the charging current causes the electrolyte acid content to increase, the charging current will likewise increase.

Modification basis	
Application basis	
Affected VIN	

4) Charging a Completely Discharged Battery (Off the Vehicle)

Unless this procedure is properly followed, a perfectly good battery may be needlessly replaced. The following procedure should be used to recharge a completely discharged battery:

1. Measure the voltage at the battery terminals with an accurate voltmeter.
If the reading is below 10 volts, the charge current will be very low, and it could take some time before the battery accepts the current in excess of a few milliamperes.
Refer to "Charging Time Required" in this section, which focuses on the factors affecting both the charging time required. Such low current may not be detectable on ammeters available in the field.
Set the battery charger on the high setting.
- 2.

CAUTION

Some chargers feature polarity protection circuitry, which prevents charger unless the charger leads are correctly connected to the battery terminals. A completely discharged battery may not have enough voltage to activate this circuitry, even though the leads are connected properly, making it appear that the battery will not accept charging current. Therefore, follow the specific charger manufacturer's instruction for by passing or overriding the circuitry so that the charger will turn on and charge a low-voltage battery.

3. Continue to charge the battery until the charge current is measurable. Battery chargers vary in the amount of voltage and current provided. The time required for the battery to accept a measurable charger current at various voltages may be as follows:

Voltage	Hours
16.0 or more	Up to 4 hours
14.0 - 15.9	Up to 8 hours
13.9 or less	Up to 16 hours

- If the charge current is not measurable at the end of the above charging times, the battery should be replaced.
- If the charge current is measurable during the charging time, the battery is good, and charging should be completed in the normal manner.

CAUTION

It is important to remember that a completely discharged battery must be recharged for a sufficient number of ampere hours (AH) to restore the battery to a usable state.

- If the charge current is still not measurable after using the charging time calculated by the above method, the battery should be replaced.

Modification basis	
Application basis	
Affected VIN	

5) Jump Starting Procedure

1. Position the vehicle with the charged battery so that the jumper cables will reach from the charged battery to the battery that requires charging.
2. Turn off the ignition, all the lights, and all the electrical loads in both vehicles.
3. Leave the hazard flasher on if jump starting where there may be other traffic and any other lights needed for the work area.
4. Apply the parking brake firmly in both vehicles.

CAUTION

In order to avoid damaging the vehicle make sure the cables are not on or near pulleys, fans, or other parts that will move when the engine starts.

5. Shift an automatic transmission to PARK.

CAUTION

In order to avoid injury, do not use cables that have loose or missing insulation.

6. Clamp one end of the first jumper cable to the positive terminal on the booster battery. Make sure it does not touch any other metal parts.
7. Clamp the other end of the same cable to the positive terminal on the discharged battery. Never connect the other end to the negative terminal of the discharged battery.

CAUTION

Do not attach the cable directly to the negative terminal of the discharged battery. Doing so could cause sparks and possible battery explosion.

8. Clamp one end of the second cable to the negative terminal of the booster battery.
9. Make the final connection to a solid engine ground, such as the engine lift bracket at least 450 millimeters (18 inches) from the discharged battery.
10. Start the engine of the vehicle with the good battery.
Run the engine at a moderate speed for several minutes.
11. Then start the engine of the vehicle with the discharged battery.
12. Remove the jumper cables by reversing the above sequence exactly, removing the negative cable from the vehicle with the discharged battery first.
While removing each clamp, take care that it does not touch any other metal while the other end remains attached.

6) Alternator

Alternators are equipped with internal regulators.

Unlike three-wire generators, the alternator may be used with only two connections: battery positive and an "D+" terminal to the charge indicator lamp.

As with other charging systems, the charge indicator lamp lights when the ignition switch is turned to RUN, and goes out when the engine is running.

If the charge indicator is on with the engine running, a charging system defect is indicated. This indicator light will glow at full brilliance for several kinds of defects as well as when the system voltage is too high or too low.

The regulator voltage setting varies with temperature and limits the system voltage by controlling rotor field current.

Achieve correct average field current for proper system voltage control by varying the on-off time. At high speeds, the on-time may be 10 percent and the off-time 90 percent.

At low speeds, with high electrical loads, the on-time may be 90 percent and the off-time 10 percent.

7) Charging System

Generators use a new type of regulator that incorporates a diode trio.

A Delta stator, a rectifier bridge, and a rotor with slip rings and brushes are electrically similar to earlier generators.

A conventional pulley and fan are used.

There is no test hole.

8) Starter

Wound field starter motors have pole pieces, arranged around the armature, which are energized by wound field coils.

Enclosed shift lever cranking motors have the shift lever mechanism and the solenoid plunger enclosed in the drive housing, protecting them from exposure to dirt, icy conditions, and splashes.

In the basic circuit, solenoid windings are energized when the switch is closed.

The resulting plunger and shift lever movement causes the pinion to engage the engine flywheel ring gear.

The solenoid main contacts close. Cranking then takes place.

When the engine starts, pinion overrun protects the armature from excessive speed until the switch is opened, at which time the return spring causes the pinion to disengage.

To prevent excessive overrun, the switch should be released immediately after the engine starts.

Modification basis	
Application basis	
Affected VIN	

9) Starting System

The engine electrical system includes the battery, the ignition, the starter, the generator, and all the related wiring.

Diagnostic tables will aid in troubleshooting system faults. When a fault is traced to a particular component, refer to that component section of the service manual.

The starting system circuit consists of the battery, the starter motor, the ignition switch, and all the related electrical wiring.

All of these components are connected electrically.

دیجیتال خودرو

شرکت دیجیتال خودرو سامانه (مسئولیت محدود)

اولین سامانه دیجیتال تعمیرکاران خودرو در ایران



Modification basis	
Application basis	
Affected VIN	

REMOVAL AND INSTALLATION

1452-01 GENERATOR REPAIR INSTRUCTIONS

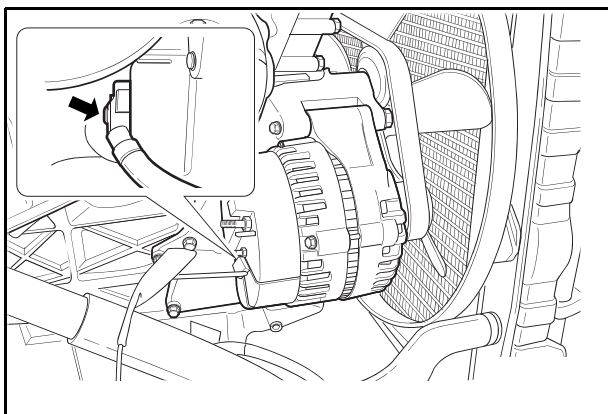

Preceding work Removal of the polly V-belt

Removal & Installation Procedure

1. Disconnect the negative battery terminal.
2. Unscrew the nut and disconnect the terminal (1).

Installation Notice

Tightening torque **14 - 18 Nm**
(10 - 13 lb-ft)

3. Unscrew the nut and disconnect the terminal (2).

Tightening torque **4 - 5 Nm**
(35 - 44 lb-in)

4. Unscrew the combination bolt (3).

Tightening torque **42 - 50 Nm**
(31 - 37 lb-ft)

5. Remove the generator.
6. Installation should follow the removal procedure in the reverse order.

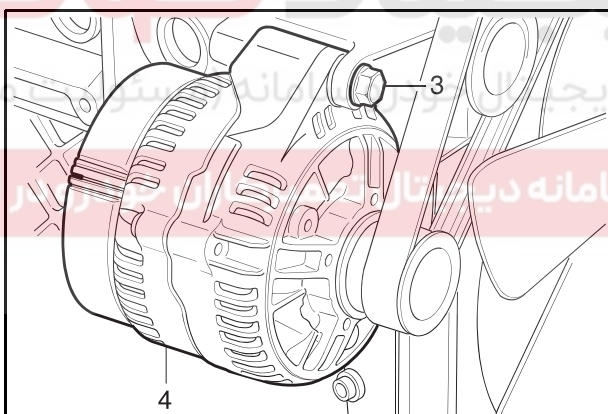

Modification basis	
Application basis	
Affected VIN	

S.G.N.
1462-01

STARTER REPAIR INSTRUCTIONS

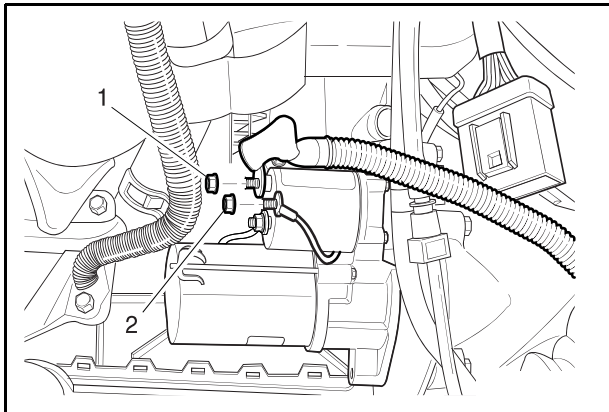

1. Disconnect the negative battery terminal.
2. Unscrew the nut and disconnect the battery cable(1).

Tightening torque 12 - 15 Nm
(9 - 11 lb-ft)

3. Unscrew the nut and disconnect the engine electric wire (2).

Tightening torque 6 - 7 Nm
(53 - 62 lb-ft)

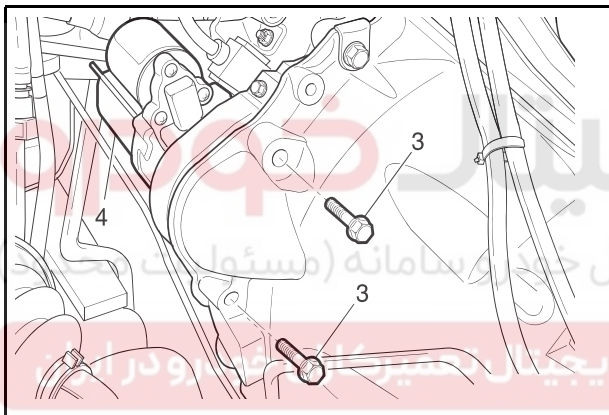

4. Unscrew the mounting bolts (3) of starter.

Tightening torque 35 - 48 Nm
(26 - 35 lb-ft)

5. Remove the starter.
6. Installation should follow the removal procedure in the reverse order.

S.G.N.

2610-01 BATTERY REPAIR INSTRUCTIONS

Removal & Installation Procedure

CAUTION

Disconnect the negative battery cable first.
Insert the clamp bolt (8) into the battery tray hole (11) from inside when installing.

1. Disconnect the negative battery cable and then disconnect the positive battery cable.

Tightening torque 12 - 18 Nm
(9 - 13 lb-ft)

2. Remove the nut from the battery clamp bolt that fasten the battery holddown bracket.

Tightening torque 15 Nm (11 lb-ft)

3. Remove the battery.
4. Installation should follow the removal procedure in the reverse order.

یجیتال خودرو

شبکه دیجیتال خودرو سامانه (مسئولیت محدود)

سامانه دیجیتال تعمیرکاران خودرو در ایران

Modification basis	
Application basis	
Affected VIN	

S.G.N.
1440-01 SPARK PLUG AND IGNITION COIL REPAIR INSTRUCTIONS

Preceding work Removal of intake air duct

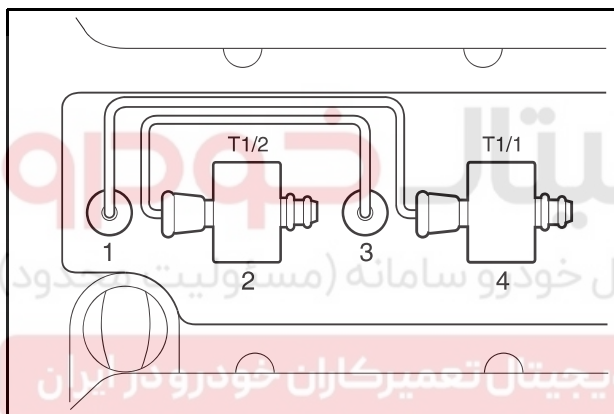
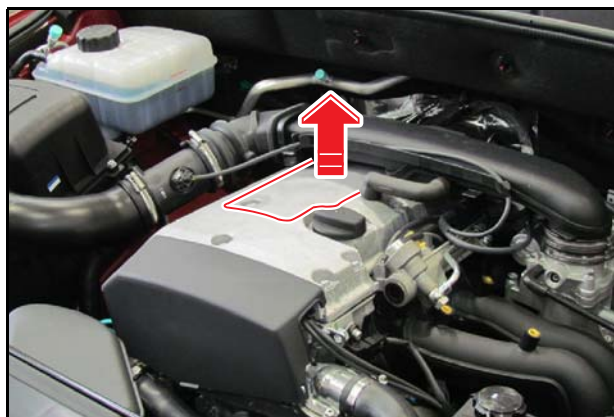

Replacement Procedure

1. Disconnect the negative battery cable.
2. Remove the ignition cable cover bolts and remove the ignition cable cover.

Tightening torque **9 - 11 Nm**
(80 - 97 lb-ft)

3. Separate the ignition cable from the ignition coil and the spark plug.
4. Remove the two bolts (M6 X 25) from each ignition coil and remove the ignition coil.

Tightening torque **9 - 11 Nm**
(80 - 97 lb-ft)

- Make sure that the ignition cables are correctly routed.
 - Exactly install the ignition cable guide pin into the vehicle to be grounded.
 - The ignition cables are located on the cylinder head cover.
- Each ignition coil provides the high voltage to two spark plugs simultaneously.

T 1/1 : Cylinder 1 and 4
 T 1/2 : Cylinder 2 and 3

5. Remove the spark plug using the spark plug wrench.

Tightening torque **25 - 30 Nm**
(15 - 22 lb-ft)

Clearance	0.8 + 0.1 mm
-----------	--------------

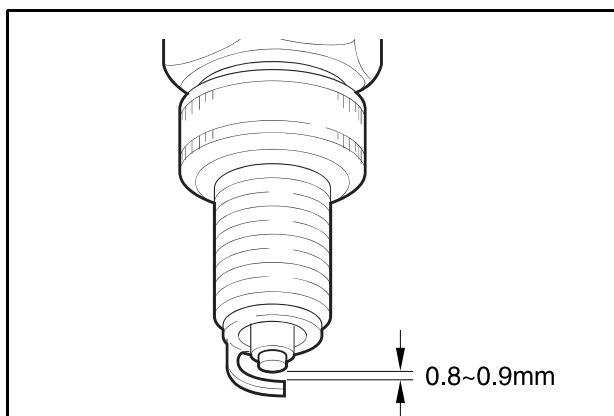

6. Installation should follow the removal procedure in the reverse order.

Modification basis	
Application basis	
Affected VIN	